

VOLVO BACKHOE LOADER

BL71, BL71 PLUS



- **Gross Power:**
SAE :
BL71 : 70 kW / 94 HP
BL71 Plus : 75 kW / 100 HP
- **Net Power:**
EEC 80/1269:
BL71 : 68 kW / 90 HP
BL71 Plus : 70 kW / 94 HP
- **Operating Weight:**
7984 / 9995 kg
- **Bucket Capacities:**
Backhoe: 0,20 m³
Loader : 1 m³
- **SAE Max Digging depth:**
4292 - 5354 mm

- **VOLVO exclusive "Self-Leveling" linkage**, single cylinder offers an impressive digging force and excellent visibility.
- Loader is controlled by a **hydraulic joystick** for smooth loading.
- **Backhoe boom is of a curved design** for easy loading.
- **Backhoe cylinders are cushioned** to eliminate jolting.
- Rigid hydraulic lines are cleanly routed inside the boom.

- **Hydraulic circuit is closed center, load sensing**, for optimum power using.
- **Control valve is "Flow Sharing"** for simultaneously performing functions.
- **Excellent serviceability at the ground level** via a fully rear-tilting bonnet.
- **Service points are grouped together** and easily accessible.

MORE CARE. BUILT IN.



SPECIFICATIONS

Engine

Low emission engine conforming EPA TIER III / Stage IIIA regulation, with reduced fuel consumption.

	BL71	BL71 Plus
Model	Volvo D5D	Volvo D5D
N° of cylinder	4	4
Displacement	4,8 l	4,8 l
Aspiration	Turbo	Turbo
Compression ratio	18:01	18:01
Gross power	70 kW (94 hp)	75 kW (100 hp)
Net power	68 kW (90 hp)	70 kW (94 hp)
Rated speed	2200 rpm	2200 rpm
Max torque	400 Nm @ 1600 rpm	420 Nm @ 1600 rpm

Electrical system

	BL71 - BL71 Plus
Rated volt age	12V
Battery capacity	110 Ah
Alternator rating	95 Amps

Hydraulic system

Flow sharing system: when the control valve is performing two or more functions simultaneously, flow sharing automatically maintains the pressure and flow for each function.

	BL71 - BL71 Plus
System	Close center
Type	Load Sensing
Pumps type	Variable flow
Distributor	"Flow Sharing"
Max flow	160 l/min
Working pressure	250 bar
System capacity	130 l

Double regulating piston pump.

Steering

Orbitrol type steering valve given priority in hydraulic system.

	BL71 - BL71 Plus
Type	Load sensing hydrostatic
Turns lock to lock	4
Turning radius:	
Between walls	5,3 m
Turning radius:	
Curb-curb	4 m

Weight

(Standard machine with 4 in 1 loader bucket, 600 mm backhoe bucket, counterweight, operator and full fuel tank, extendible dipper)

	BL71 - BL71 Plus
Operating weight	7984 kg / 9995 kg

Brakes

Multi-plate, oil immersed, power assisted, self-adjusting disc brakes with four wheel braking automatically engaged in third and fourth gear. Total integral braking on the 4 wheels.

	BL71 - BL71 Plus
Type	Oil immersed disc brakes
Number of discs	2 for each wheel
Parking and safety brake	external disc on rear axle input shaft

Drivetrain

	BL71 - BL71 Plus
Final drive type	External planetaries
Total oscillation angle	16°
Differential locking	100%

Front axle

Load rating, Static	24218 kg
Load rating, Dynamic	9687 kg

Rear axle

Load rating, Static	19120 kg
Load rating, Dynamic	7648 kg

Transmission

Powershuttle gear box with four forward and four reverse fully synchronized gears. Electro-hydraulic forward/reverse switch on the steering column and on the loader joystick.

Travel speed

Maximum speed, forward/reverse

	BL71 - BL71 Plus
1	5,9 km/h
2	9,7 km/h
3	19,5 km/h
4	37 km/h

Optional Powershift transmission with four forward and reverse speeds and a standard kick down shift control for immediate shifting from second to first gear. Automatic mode is activated when fourth gear is engaged.

Service fill capacities

	BL71 - BL71 Plus
Cooling system	19 l
Fuel tank	120 l
Engine oil (w/filter)	14 l
Rear axle	
Differential oil capacity	14,5 l
Front axle (4WD)	
Differential oil capacity	6,5 l
Hydraulic reservoir	41 l
Hydraulic system	130 l

Backhoe performance

The boom is of a curved design for easier truck loading.

	BL71 - BL71 Plus
Standard dipper	
Bucket width	610 mm
Bucket capacity	0,20 m ³
Bucket digging force	59,1 kN
Dipper digging force	38,8 kN

Extendible Backhoe: performance

Bucket capacity	0,20 m ³
Bucket digging force	59,1 kN

Dipper digging force

Ret. -	38,8 kN
Ext. -	28,5 kN

Bucket rotation	194°
Swing torque	26 kNm

Loader performance

Standard loader is a self-leveling, single cylinder loader type.

Volvo patented system.

	BL71 - BL71 Plus
Bucket width	2350 mm
Bucket capacity	1,0 m ³
Lifting capacity at full height	3320 kg
Bucket Breakout force	55.4 kN (53.8 kN - MP)

Features:

Return-to-dig	Standard
Lube interval (hrs)	> 50
Number of bucket cylinders	1
Boom Suspension System	Optional

Tyres

Large front tyres give great loading performance.



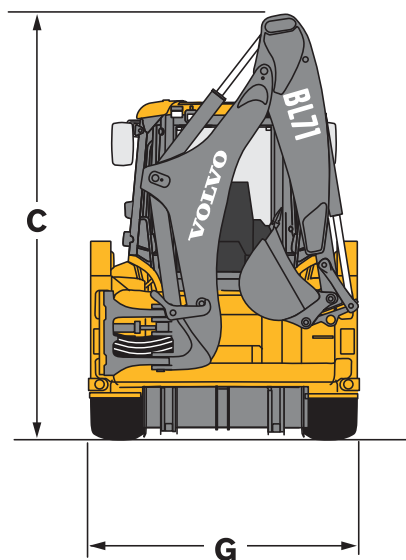
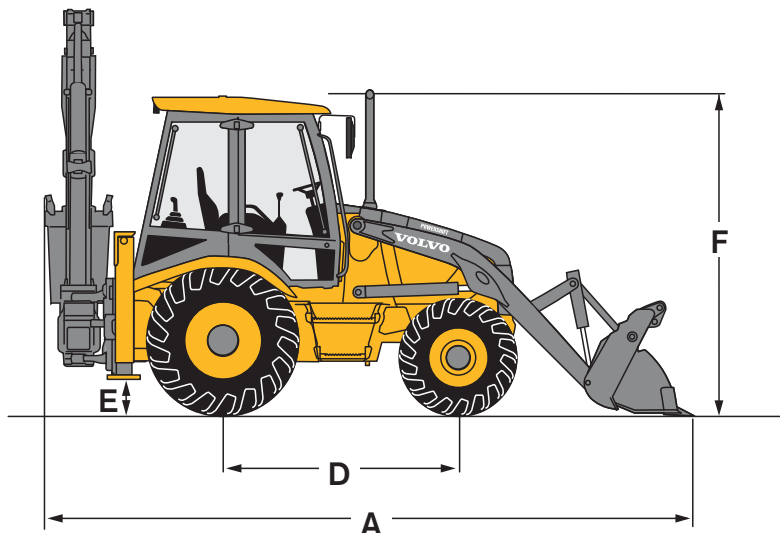

Rear: 18,4 x 26



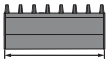

Front: 16/70 x 20



Dimensions - Transport Position

	BL71	BL71 Plus
A - Overall length	5812 mm	5939 mm
B - Overall width	2477 mm	2477 mm
C - Overall height	3746 mm	3746 mm
D - Wheelbase 4wd	2191 mm	2191 mm
E - Stabiliser clearance	372 mm	372 mm
F - Height to top of ROPS (cab)	2938 mm	2938 mm
G - Stabiliser Width	2300 mm	2300 mm

Backhoe buckets	 Width	 Weight	 Capacity	 Teeth nbr.
Standard bucket	2350 mm	450 kg	1000 l	8
4 in 1 bucket	2350 mm	784 kg	1000 l	8

Backhoe buckets	 Width	 Weight	 Capacity	 Teeth nbr.
Standard bucket	300 mm	90 kg	74 l	3
	400 mm	101 kg	110 l	3
	450 mm	109 kg	128 l	4
	610 mm	126 kg	190 l	4
Grading bucket	910 mm	164 kg	309 l	6
	1215 mm	135 kg	160 l	0
	1515 mm	158 kg	210 l	0

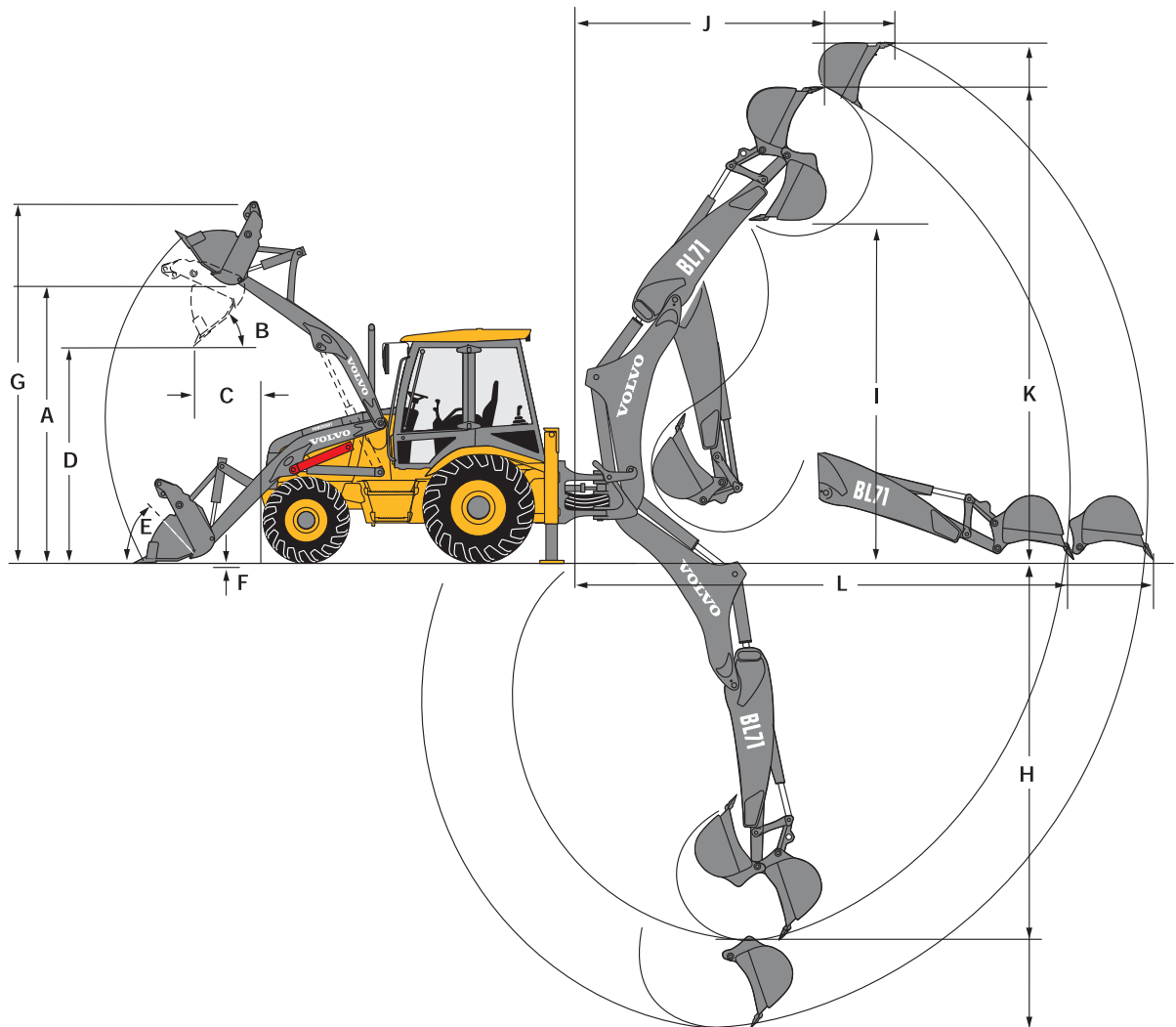

Loader dimensions

	BL71	BL71 Plus
A - Height to hinge pin	3460 mm	3460 mm
B - Dump angle	49 °	49 °
C - Dump reach @ 45°	828 mm	955 mm
D - Dump height @ 45°	2717 mm	2594 mm
E - Rollback at ground	44°	44°
F - Dig depth below grade	155 mm	153 mm
G - Overall operating height	4470 mm	4594 mm
Max grading angle	117 °	117 °

Backhoe dimensions

	BL71	BL71 Plus
Standard dipper		
H - SAE max digging depth	4292 mm	4292 mm
I - Loading clearance	3815 mm	3815 mm
J - Reach at max height	2875 mm	2875 mm
K - Max operating height	5567 mm	5567 mm
L - Reach from swing post	5859 mm	5859 mm
Sideshift offset from centreline	570 mm	570 mm
Max digging depth	4987 mm	4987 mm

Extendible dipper dimensions

	BL71	BL71 Plus
H - SAE max digging depth		
Ret.	4292 mm	4292 mm
Ext.	5354 mm	5354 mm
I - Loading clearance		
Ret.	3815 mm	3815 mm
Ext.	4427 mm	4427 mm
J - Reach at max height		
Ret.	2875 mm	2875 mm
Ext.	3752 mm	3752 mm
K - Max operating height		
Ret.	5567 mm	5567 mm
Ext.	6180 mm	6180 mm
L - Reach from swing post		
Ret.	5859 mm	5859 mm
Ext.	6827 mm	6827 mm
Max digging depth	6006 mm	6006 mm

STANDARD EQUIPMENT

Engine

BL71: Volvo D5D turbocharged diesel engine (70 kW).
BL71 Plus: Volvo D5D turbocharged diesel engine (75 kW).
Engine fan guard.
Ground line fuel fill with 120 liter capacity.
Front grill.
Tilting cooler.

Electrical System

Battery, 690 CCA.
Alternator 95 Amp.

Service and Maintenance

Tool box - external.
50-hour greasing intervals.

Hydraulic System

Hydraulic oil cooler.
Load sensing, variable flow system with axial piston pump.
"Flow Sharing" System.

Lighting

Hazard flasher/direction indicators.
Light, working (2 front, 2 rear).
Front headlights.

Instrumentation & controls

Gauges:
• Coolant temperature
• Fuel level

- Hour recorder
- Headliner

Warning and control lamps:
• Preheating element engine
• High coolant temperature engine
• Low oil pressure engine,
• Air filter engine,
• High oil temperature transmission,
• Service indicator
• Battery charging
• Hydraulic oil filter
• High hydraulic oil temperature
• Low hydraulic oil temperature
• Warning and control lamps.

Power socket.
Horn.
Warning buzzer.
Reversing alarm.
Throttles, hand and foot.

Driveline

Four wheel drive.
Oil immersed disc brakes.
Differential lock.
Fast reversing shuttle, all gears.
Torque convertor.
Four-speed synchromesh transmission.
Neutral transmission button on loader joystick.
Transmission de-clutch on loader joystick.
Tyres.

Cab, Exterior

Left/right side doors with locks.
4 side opening windows with partial & full hold open.
One-piece opening rear window.
Front windscreen - laminated.
Mirrors external (2).
All tinted glass.

Cab, Interior

Interior light.
Drink holder.
Ignition switch.
Front and rear windscreen wipers.
Front and rear windscreen washer.
Floor mat.
Seat with fabric or vinyl seat cover with or without arm rests.
Defroster.
Seat belt, retractable.
Steering wheel.
Power steering.
Hydrostatic heater.

Working Equipment

Backhoe, side-shift, excavator - two lever control.
Hydraulic boom transport lock.
Sideshift, locking.
Swing transport lock.
Loader, self-levelling with return-to-dig and transmission disconnect switch on loader joystick.

OPTIONAL EQUIPMENT

Cab

Air Conditioning.
Radio ready.
Air suspension and heated seat + arm rests.
Radio.
Speedometer.
Sun visor.
Wide seat belt.
Tilt steering wheel.

Driveline

Powershift transmission.
Front fenders.
Rear fenders extension

Working Equipment

Excavator Pilot Controls (BL71).
Boom suspension system.
Extendible dipper.
Stabiliser street pads.
Drive shaft guard.
Cyclonic pre-filter.
Lifting eye backhoe.

Hydraulics

Hammer hydraulic circuit.
Hammer rigid line.
Hand held hydraulic.
Bi-Directional Auxiliary hydraulic circuit.

Lighting

Additional working lights (2 front, 2 rear).

Electrical System

Battery, additional.
Engine pre-heater.

Safety

Hydraulic oil tank lockable cap.
Rotating beacon.
Boom and dipper safety valves.
Loader safety valve.
Vandal guard.
Anti-theft key board.
Back up alarm.

Special colours.

ATTACHMENTS

Loader

Loader Attachment Bracket (TPV)
General Purpose bucket.

Multi-Purpose bucket.
Forks kit for Loader Attachment Bracket.
Flip-over forks for GP and MP buckets.

Excavator

Standard and Heavy Duty buckets.
Mechanical attachment bracket.

Volvo breaker HB 440.



Volvo Construction Equipment is different. It's designed, built and supported in a different way. That difference comes from an engineering heritage of over 175 years. A heritage of thinking first about the people who actually use the machines. About how to help them be safer, more comfortable, more productive. About the environment we all share. The result of that thinking is a growing range of machines and a global support network dedicated to helping you do more. People around the world are proud to use Volvo. And we're proud of what makes Volvo different - **More care. Built in.**



Not all products are available in all markets. Under our policy of continuous improvement, we reserve the right to change specifications and design without prior notice. The illustrations do not necessarily show the standard version of the machine.

VOLVO

Volvo Construction Equipment
www.volvoce.com

PUB 21 3 432 1198
2010.04
Volvo, Global Marketing

English (Global)
BHL