



Volvo Construction Equipment

P8720B_{ABG}

VOLVO TRACKED PAVERS 2.5-9 m 170 kW



A passion for performance.

At Volvo Construction Equipment, we're not just coming along for the ride. Developing products and services that raise productivity – we are confident we can lower costs and increase profits for industry experts. Part of the Volvo Group, we are passionate about innovative solutions to help you work smarter – not harder.

Helping you to do more.

Doing more with less is a trademark of Volvo Construction Equipment. High productivity has long been married to low energy consumption, ease of use and durability. When it comes to lowering life-cycle costs, Volvo is in a class of its own.

Designed to fit your needs.

There is a lot riding on creating solutions that are suited to the particular needs of different industry applications. Innovation often involves high technology – but it doesn't always have to. Some of our best ideas have been simple, based on a clear and deep understanding of our customers' working lives.



You learn a lot in 180 years.

Over the years, Volvo has advanced solutions that have revolutionized the use of construction equipment. No other name speaks Safety louder than Volvo. Protecting operators, those around them and minimizing our environmental impact are traditional values that continue to shape our product design philosophy.

We're on your side.

We back the Volvo brand with the best people. Volvo is truly a global enterprise, one that is on standby to support customers quickly and efficiently – wherever they are.

We have a passion for performance.



Volvo Trucks



Renault Trucks



Mack Trucks



UD Trucks



Volvo Buses



Volvo Construction Equipment



Volvo Penta



Volvo Financial Services

Paving the way in productivity.

Introducing the P8720B ABG, a new paver from Volvo designed specifically for the Chinese market. Born from the ABG legacy, this machine is primarily intended for use on cold materials – such as cement treated base (CTB) – but can also pave other mixes. With a larger auger and hopper, this tracked paver is built for maximum productivity.

Conveyor tunnel

The conveyor tunnel has been adapted for high material throughput – allowing the paver to place an impressive 1000 t/h.

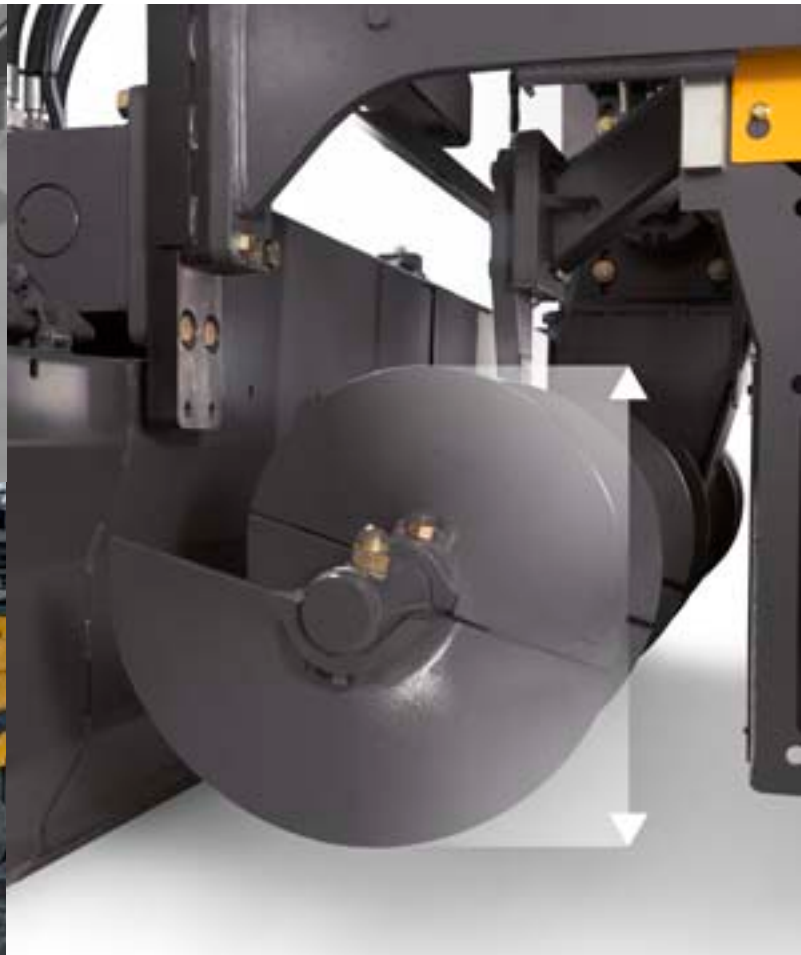

Hopper capacity

The large 15 ton hopper capacity supports uninterrupted material supply and continuous thick mat paving. The longer design also provides the clearance needed for Chinese trucks when fully dumping – allowing them to unload quickly for uninterrupted paving.

Larger auger

Accurate control of material into the auger channel ensures that there is a consistent amount ahead of the screed. The large 420mm auger diameter provides a constant flow – ensuring the highest quality mat.



400mm layer thickness

Pave up to 400mm mat thickness with the P8720B ABG paver. The machine has a concrete double tamper (CDT) screed which delivers superior density levels and consistently smooth, high quality results.



Volvo engine

The powerful, 170kW Volvo 7 liter engine is built with advanced technology and on decades of experience. The state-of-the-art, Volvo-maintained engine delivers the ultimate combination of high power and low fuel consumption.

Superior Volvo power.

If you're looking for a powerful and efficient paver then look no further than the P8720B ABG. Designed and built 100% by Volvo, the machine combines proven technology and innovative engineering to deliver superior mat quality, uniformity and smoothness. Boost your paving power and experience enhanced engine performance and greater fuel economy with Volvo.

Smart power mode

When paving conditions do not require full power, the operator can select smart power mode on the electronic paver management (EPM II) control panel to automatically reduce engine rpm. This results in a 30% reduction in fuel consumption and noticeably lower noise levels.



Large contact area

The large contact area of the crawler tracks, together with optimal machine weight distribution, ensures the effective transfer of engine power to the surface – providing high quality paving in all conditions.

Balanced design

The heavy machine weight is evenly distributed over the large track contact area to provide maximum traction, stability and maneuverability. Paver weight and traction combined with engine power delivers optimum performance.

Demand the best.

Experience top to bottom Volvo quality with the P8720B ABG paver. Packed with features which help to reduce wear and increase uptime, this robust machine delivers durability you can count on. Get the job done with Volvo.

Truck interface

The paver has been specifically adapted to suit Chinese haul trucks – the front crossbeam is extended by 200mm to prevent the truck bed interfering with the paver wall in the hopper. The crossbeam, used to mount the push rollers, has an oscillating frame to compensate for minor directional misalignment of the truck wheels when dumping material into the hopper.

Sealed bearings

The durable design of the conveyor and auger system bearings ensures protection from the harsh environment of the material flow system – providing long life and increased uptime.

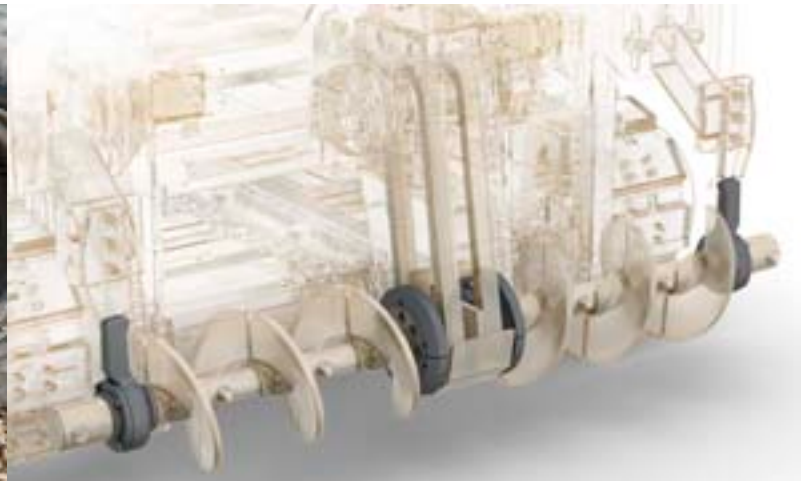

Severe application protection

For the most extreme, heavy-duty applications Volvo offers two optional kits for additional wear protection in the material flow system. These wear-resistant parts can be factory fitted or ordered from your local Volvo dealer.

Track support roller

Two track support rollers secure the chain in place, preventing it from sliding on the frame for increased durability and component lifetime.

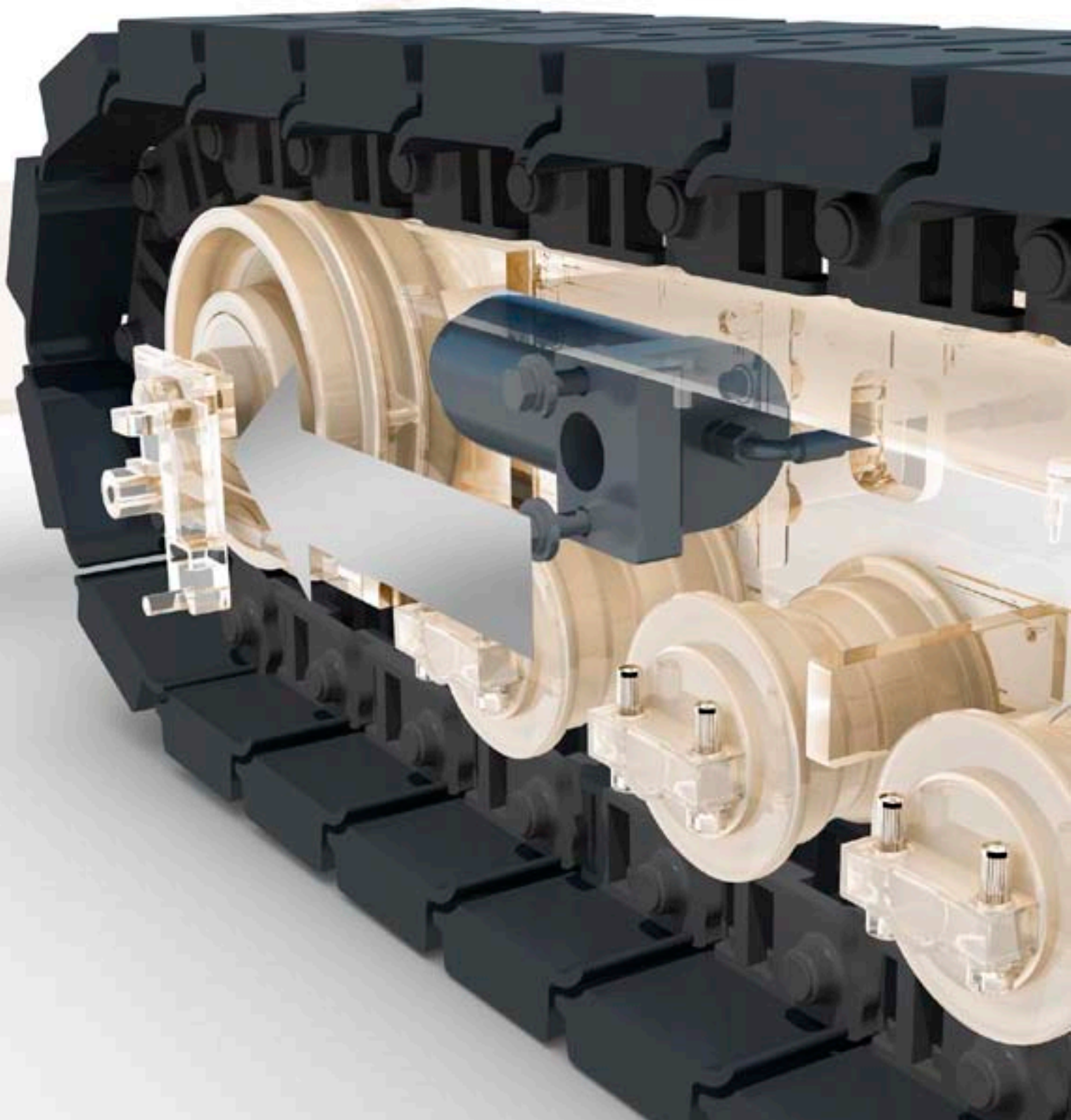

Automatic track tensioner

The hydraulic track tensioning adjustment system constantly maintains the correct track tension for smooth operation and high quality mat. The system reduces track component wear and increases machine uptime.



EPM II

Quickly and easily access information with Volvo's EPM II. For easy identification, all controls on the panel are shown as they are located on the machine. Designed for simple operation and maximum efficiency, the back-lit display allows the operator to select and adjust paver settings.

The Volvo P8720B ABG paver is built for performance and precision in CTB applications. Featuring double tamper bars and Volvo's EPM II (Electronic Paver Management) technology, you'll experience superior density levels and intelligent paving at its best.

High-performance paving.

Double tamper

Double tamper bars provide the highest levels of CTB compaction density behind the screed – essential when paving a thick layer of mat. This reduces the amount of roller compaction, saving time and money.

Proportional steering control

The electrohydraulic system delivers smooth, precise steering control on both curves and straight stretches.

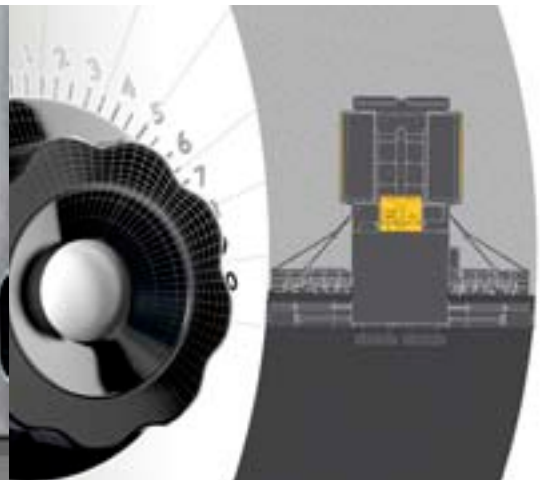
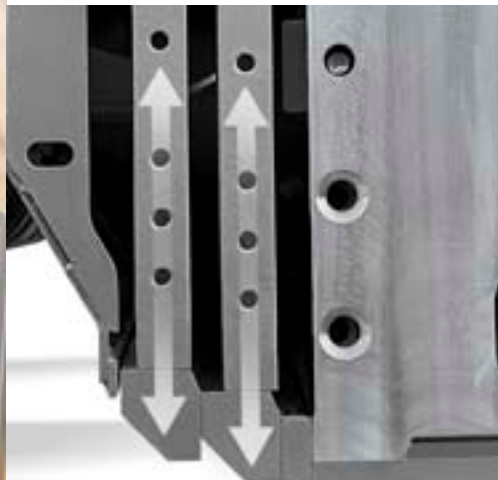

Adjustable auger

The auger assembly height can either be manually or hydraulically adjusted to vary and manage the flow of material through the paver. This ensures that material is evenly distributed in front of the screed which is essential for achieving high quality mat.

Constant material flow

The increased hopper capacity together with the size and speed of the conveyors and the auger transfer rate provides smooth material flow and greater throughput capacities to the screed.

Paving perfection.



400mm layer thickness

Pave up to 400mm mat thickness with superior density levels and consistently smooth, high quality results.

Conveyor tunnel

The conveyor tunnel has been adapted for high material throughput – allowing the paver to place an impressive 1000 t/h.



Volvo engine

The powerful, 170kW Volvo 7 liter engine delivers the ultimate combination of high power and low fuel consumption.



Hopper capacity

The large 15 ton hopper capacity supports uninterrupted material supply and continuous thick mat paving.



Automatic track tensioner

The hydraulic track tensioning adjustment system constantly maintains the correct track tension for smooth operation, high quality mat and reduced track component wear.

Large contact area

The large contact area of the crawler tracks, together with optimal machine weight distribution, ensures the effective transfer of engine power to the surface.



Truck interface

The paver has been specifically adapted to suit Chinese haul trucks – the front crossbeam is extended by 200mm to prevent the truck bed interfering with the paver wall in the hopper.

Double tamper

Double tamper bars provide the highest levels of CTB compaction density behind the screed – essential when paving a thick layer of mat.



EPM II

The intuitive design of the electronic paver management (EPM II) panel allows the operator to easily control paver settings.

Severe application protection

For the most extreme, heavy-duty applications Volvo offers two optional kits for additional wear protection in the material flow system.



Service support

Volvo Construction Equipment has a unique, global dealer support network to ensure your paver's uptime and availability.

Smart power mode

Select smart power mode on the EPM II to automatically decrease engine rpm. This reduces fuel consumption by 30% and lowers noise levels.

Proportional steering control

The electrohydraulic system delivers smooth, precise steering control on both curves and straight stretches.

Uptime goes up with Volvo.

Boost your uptime with the new P8720B ABG paver from Volvo. Engineered for long life, high uptime and maximum productivity, this machine is loaded with time saving features. And with Volvo's unique dealer support network, you'll be able to work for longer and sustain productivity day in and day out.

Interchangeable ECUs

For added convenience, the three electronic control units (ECUs) are interchangeable. Each ECU can control all paver functions.

Split tow arms

The split tow arms enable quick and easy removal of the screed by separating it from the tractor at the split joint. The system includes an adjustable spacer that allows the screed to pave different thicknesses up to 400mm.



Hydraulic oil filter

The highly efficient, single hydraulic oil filter has a service interval of up to 3000 hours. This reduces maintenance requirements and costs while also increasing machine uptime.

Central lubrication

A central lubrication assembly greases the conveyor shaft and the auger support bearing assemblies. The system provides consistent lubrication, reducing maintenance requirements and increasing bearing life.



Service support

Volvo Construction Equipment has a unique, global dealer support network to ensure your machine's uptime and availability. Because Volvo pavers are 100% Volvo, you'll enjoy maintenance made easy and continuous state-of-the-art support.

Specifications.

Model	P8720B ABG		
Engine (Diesel)			
Make	Volvo		
Model	D7E GEE3		
Output	kW/hp	170 / 231 @ 1800 rpm	
Coolant	Liquid		
Fuel tank capacity	l	240	
Exhaust emission	COM IIIA / EPA Tier 3		
Paving			
Output (theor.)*	t/h	1 000	
Mat thickness (max.)	mm	400	
Speed			
Paving	m/min	20	
Transport	km/h	3.6	
Undercarriage			
Track length	mm	2 965	
Width (track plates)	mm	300	
Mix conveyor system			
Hopper capacity	t	15	
Conveyors	2		
Conveyor speed	m/min	28	
Auger			
Auger speed	1/min	95	
Auger diameter	mm	360 / 420	
Electrics			
Vehicle Voltage	Volt	24	
Transport dimensions			
Width	mm	2 535	
Length with screed	mm	6 372	
Height	mm	2 993	
Weight**			
Tractor unit	kg	14 850	

* The actual paving output depends upon the mat thickness, the paving width and paving speed and will vary according to paving conditions prevailing on your jobsite. Please approach us and we will be pleased to assist you in calculating the paving output for your particular paving project

** All weights are approx. weights without options. Weight of the tractor: tires filled with water, Diesel tank half-full and weather roof included.

OPERATING WEIGHTS¹ OF SCREED

Model	CDT 121								
At working width	2.5 m	3.5 m	4 m	4.5 m	5 m	5.5 m	6 m	7 m	9 m
kg	2 070	2 750	3 230	3 490	3 860	4 320	4 780	5 550	6 870

¹ Including auger extensions, channel plates, end gates, towing arms rear etc.

DIMENSIONS		P8720B ABG
Unit		mm
A		6 489
B		2 965
C		405
D		295
E		450
F		490 ± 120
G		2 340
H		3 751
I		1 431
J		630
K		160
L		435
M		5 283
N		1 206
O		1 675
P		2 835
Q	up	3 788
	down	2 993
R	open	3 190
	closed	2 480
S		3 085
T		2 495
U		300
V		2 269
W		320
X		418
Y		≥12°
Z		12°

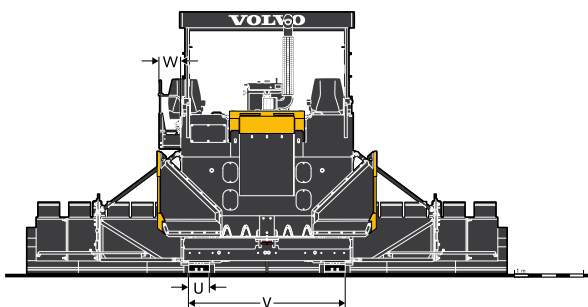
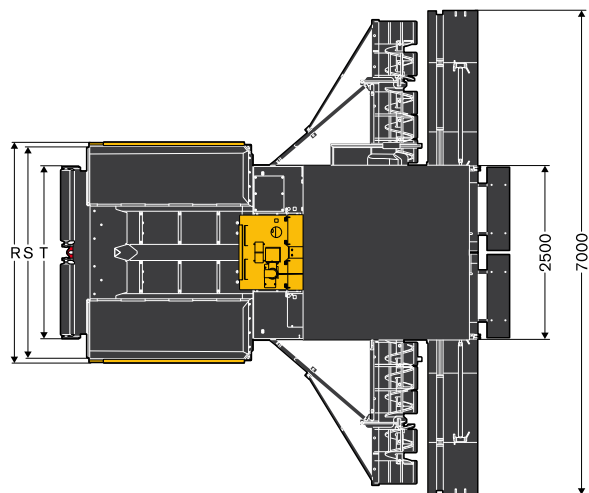
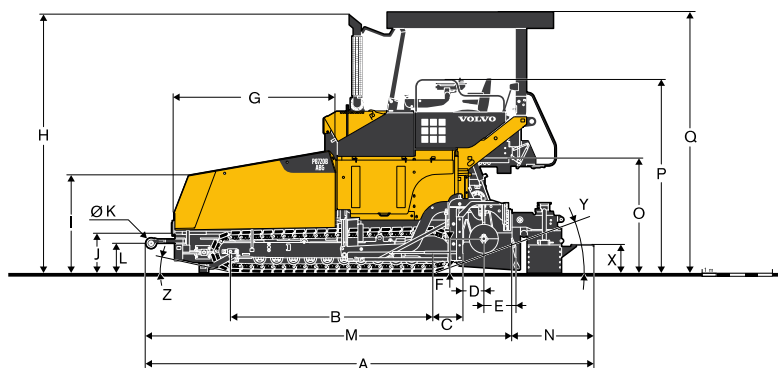

Equipment.

STANDARD EQUIPMENT

Engine

Volvo D7 diesel engine, COM 3A/EPA Tier III

Drive

Electronic drive control

Lifetime lubricated crawler track rollers

Forged and hardened crawler track links

Automatic track tensioner

Material Management

Large truck buffer rollers with 160 mm Ø

Four individual hydrostatic drives for conveyors and augers

Large 15t hopper capacity

Ultrasonic sensors for proportional auger speed control

420 mm diameter augers

Electronics

Electronic Paver Management (EPM2)

Smart power

Adjustable and revolving control unit

Electric switch cabinet

Battery master switch

Structure

All-weather canopy

Two seats, laterally extendable

MCU and SCU lockable cabinet

Screed

CDT 121 fixed screed to 7m with dual tampers

Two external screed control units

Screed split towing arms

Service

Central lubrication

Track support rollers

Environmental

Sound insulation



Large truck buffer rollers with 160 mm Ø



Ultrasonic sensors for proportional auger speed control



Two seats, laterally extendable

Standard equipment and options may vary based on local markets.
Consult local sales when building your next paver.

OPTIONAL EQUIPMENT

Material Management

Hydraulic auger height adjustment

Material scraper

Electronics

Auxiliary control panel - remote control unit

Leveling kit with two rotary sonic sensors

Digital slope sensor with slope control support

Screed

7m to 9m screed extension

Long auger extension

Lights

Driver's compartment lighting

Two additional rear lights

Auger tunnel lighting

Additional Severe Application Protection Package

Auger shaft protective half shells

Additional severe application protection conveyor covers

Additional severe application protection plates for auger and conveyor sides

SELECTION OF VOLVO OPTIONAL EQUIPMENT

Additional severe application protection plates for auger and conveyor sides



7m to 9m screed extension kit



Auxiliary control panel-remote control unit



Hydraulic auger height adjustment



Protective half shells



Auger lighting



Not all products are available in all markets. Under our policy of continuous improvement, we reserve the right to change specifications and design without prior notice. The illustrations do not necessarily show the standard version of the machine.



VOLVO

Volvo Construction Equipment

www.volvoce.com