

VOLVO MOTOR GRADER G740 / G740 VHP

TANDEM DRIVE

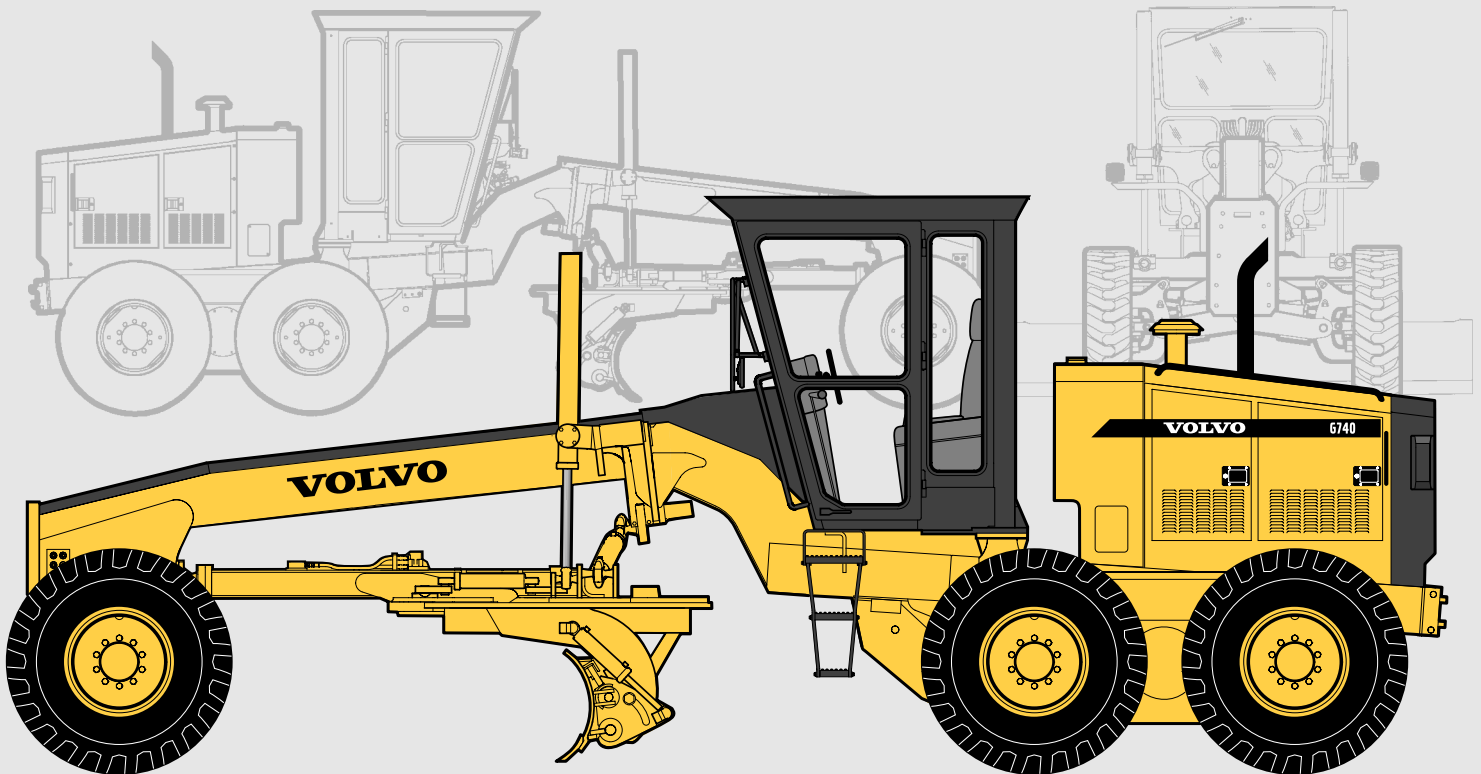

KEY FEATURES:

- 8400 fully sequential direct drive powershift transmission with 13.5" (343 mm) clutch
- Choice of fully enclosed, quiet, comfortable ROPS cab in full height or low profile configuration, or ROPS canopy
- Moveable Blade Control System
- Load sensing, closed center hydraulic system
- Fully adjustable, low effort controls
- Full front and rear frame sections for all attachment applications
- Single lever transmission control with "Smart Shifter" feature
- Hydraulically Boosted Dual Braking System with reserve power assist
- Heavy duty lock/unlock differential
- Three level electronic operator warning system
- 12' (3 658 mm) moldboard
- Full range of front and rear mounted attachments

MODEL	G740	G740 VHP
Configuration	Articulated Frame	Articulated Frame
Engine	Cummins M11	Cummins M11
Output (SAE J1349)	210 hp (157 kW)	210-235 hp (157-175 kW)
Base weight	35,610 lb (16 153 kg)	35,610 lb (16 153 kg)
Blade down pressure	18,904 lb (8 575 kg)	18,904 lb (8 575 kg)
Blade pull	22,424 lb (10 172 kg)	22,424 lb (10 172 kg)

VOLVO



BASE OPERATING WEIGHT (Standard Equipment)

Weights shown include full cab with ROPS, all operating fluids and operator.

G740 / G740 VHP

Total 35,610 lb (16 153 kg)
On front wheels 10,695 lb (4 851 kg)
On rear wheels 24,915 lb (11 302 kg)

Weight adjustments for various options are listed.

Typically equipped operating weight: includes 17.5 x 25, 12 PR, G-2 tires on 14" (356 mm) rims and 14' x 29" x 1" (4 267 mm x 737 mm x 25 mm) moldboard and scarifier.

G740 / G740 VHP 38,302 lb (17 374 kg)



PRODUCTIVITY (Standard Equipment)

Maximum blade pull (no wheel slip, 0.9 traction co-efficient) 22,424 lb (10 172 kg)

Blade down pressure

- cutting capability

(ISO 7134) 18,904 lb (8 575 kg)

Blade down pressure is the maximum downward force which may be applied at the cutting edge.



ENGINE DATA

G740

Make/Model Cummins M11
Type 4 Cycle, Turbocharged, Aftercooled
No. of cylinders In Line 6
Bore & stroke ... 4.92" x 5.79" (125 mm x 147 mm)
Displacement 660 cu in (10.8 L)
Rated gross brake horsepower
@ 2100 RPM 225 hp (168 kW)
Rated net brake horsepower
@ 2100 RPM 210 hp (157 kW)
Torque @ 1300 RPM 760 lb.ft (1 031 N.m)
Torque rise (Net) 43%

G740 VHP

Make/Model Cummins M11
Type 4 Cycle, Turbocharged, Aftercooled
No. of cylinders In Line 6
Bore & stroke 4.92" x 5.79" (125 mm x 147 mm)
Displacement 660 cu in (10.8 L)
Rated gross brake horsepower @ 2100 RPM
- Gears forward 1, 2 and
Reverse 1 225 hp (168 kW)
- Gears forward 3-8 and
Reverse 2-4 250 hp (187 kW)
Rated net brake horsepower @ 2100 RPM
- Gears forward 1, 2 and
Reverse 1 210 hp (157 kW)
Torque @ 1300 RPM 760 lb.ft (1 031 N.m)
Torque rise (Net) 45%
- Gears forward 3-8 and
Reverse 2-4 235 hp (175 kW)
Torque @ 1300 RPM 845 lb.ft (1 146 N.m)
Torque rise (Net) 43%

Engine equipped with a two stage, dual element, dry type air cleaner with evacuator and dash mounted service indicator. 24 volt starting and electrical system with 75 amp (1800 watt) brushless alternator with internal voltage regulator. Two heavy duty 12 volt maintenance free batteries with 900 cold cranking amps (CCA) and 160 minutes reserve capacity per battery. System includes battery disconnect.

Performance: Rated net brake horsepower SAE standard J1349/ISO 3046-2 conditions with water pump, lubricating oil pump, fuel system, air cleaner, muffler, alternator and cooling fan.



TRANSMISSION

Make/Model Volvo 8400
Fully sequential, direct drive, powershift transmission. Engine cannot be started if transmission is in gear. Single lever transmission controller provides electronic self-diagnostics. The flywheel mounted, multi-disc master clutch is oil cooled for long life.

Ground speeds at 2200 RPM with standard tires:

Forward		Reverse			
Gears	mph	km/h	Gears	mph	km/h
1	2.6	4.2	1	2.6	4.2
2	3.7	5.9			
3	5.1	8.2	2	5.1	8.2
4	7.1	11.4			
5	10.1	16.1	3	10.1	16.1
6	14.1	22.5			
7	19.5	31.2	4	19.5	31.2
8	27.2	43.6			

Transmission guard is standard equipment and is hinged for easy access.



DIFFERENTIAL / FINAL DRIVE

Make/Model Volvo SR40
Single reduction final drive with an operator controlled lock/unlock differential. Rear axles are case hardened, supported on double row spherical roller bearings.



TANDEMS

Oscillating tandem case has internal gusseting for maximum torsional strength. Field proven split ring/flanged sleeve tandem mounting and 1" (25 mm) thick inner wall resists flexing from side loading during severe applications.

Depth	24.50"	(622 mm)
Width	8.25"	(210 mm)
Thickness - inner wall	1.00"	(25 mm)
- outer wall	0.75"	(19 mm)
Center distance	61.50"	(1 562 mm)
Drive chain pitch	2.00"	(51 mm)
Oscillation ± 15°	



BRAKES

Service Brakes Foot operated
Fade resistant, hydraulically actuated, oil disc service brakes located at the 4 tandem drive wheels are self-adjusting, fully sealed and maintenance free. System features crossover dual braking circuits for even braking on both sides of the grader. Includes reserve power assist and operator warning system (visual and audible).

Parking Brake Hand operated
Independent, disc-type hand brake on transmission output shaft and effective on all 4 tandem drive wheels. Includes visual and audible operator warning system for parking brake on, transmission in gear condition.

Braking systems to SAE Recommended Practice J1473 OCT. 90, and J1152 APR. 80; ISO 3450-1993-01-28. Volvo uses asbestos free brake components.



WHEELS & TIRES (Standard Equipment)

Tire size 14:00 x 24, G-2
Ply rating (PR) 12
Rim size 10" (254 mm)
Bolt-on rims are interchangeable between the front wheels and the tandem wheels.



FRONT AXLE

Type Fully welded steel truss, gusseted for torsional strength, oscillates on a single 3.5" (89 mm) diameter center pivot pin

Wheel lean 18° R & L

Oscillation 16° up and down

Ground clearance 24.0" (610 mm)

Twin 3" (76 mm) diameter wheel lean cylinder with lock valve is standard equipment.



STEERING

Hydraulic power front wheel steering incorporating two steering cylinders. Meets SAE J1511 OCT. 90 with optional supplemental steering.

Minimum turning radius using front axle steering, articulation, wheel lean and unlocked differential 257" (7 798 mm)

Steering arc 72°

Frame articulation angle 22°

Articulation lock standard



FRAME

Full front and rear frame sections

Front: Fully welded box section. Dual sloped front frame provides excellent forward visibility.

Minimum dimensions of

box section 10.5" x 14.0" (267 mm x 356 mm)

Plate thickness

- Top and Bottom 1.25" (32 mm)

- Sides 1.00" (25 mm)

Vertical section modulus

at arch 163 cu in

minimum 137.7 cu in (2 256 cm³)

maximum 283.9 cu in (4 652 cm³)

Linear weight - minimum-maximum

..... 148.7 lb/ft - 244.2 lb/ft (221.3 - 363.4 kg/m)

Rear: Full rear frame permits modular powertrain mounting for ease of service and simplifies attachment mounting.

Minimum dimensions of

rear frame 4.0" x 11.0" (102 mm x 279 mm)

Plate thickness 1.0" (25 mm)



CIRCLE

Hardened teeth, cut on the outside of the circle for maximum leverage and minimum wear. Circle is fabricated from high tensile steel and all running surfaces are precision machined.

The circle is held positively in place at six points by three adjustable clamp plates and three adjustable guide shoes, providing optimum circle support and load distribution. The primary set of clamps and guide shoes is located at the front of the circle where greatest loading occurs. DURAMIDE™ faced clamp and guide shoes prevent metal-to-metal contact and provides maximum service life.

DURAMIDE™ is a synthetic bearing material that maximizes service life and reduces circle system maintenance requirements.

Diameter 66.25" (1 683 mm)

Thickness 1.25" (32 mm)

Adjustable guide shoes 3

Adjustable clamp plates 3



ARTICULATION

Twin 5" (127 mm) hydraulic cylinders articulate frame 22° right and left. Anti-drift lock valve



CIRCLE DRIVE

The Volvo dual cylinder circle drive system uses direct acting hydraulic power for exceptional turning and holding capability under full load. The circle drive system uses hardened drive pinions and is fully protected against impact damage by an overload cushion valve as standard equipment.

Hydraulic drive cylinders 2
 Points of leverage 2
 Rotation 360°



DRAWBAR

Fully welded box section. Narrow "T" design permits optimum visibility to the work area. Drawbar ball stud provides an adjustment to compensate for different tire sizes. Blade lift cylinder anchors are straddle mounted on drawbar to provide maximum strength and support.

Dimensions of box section 6.5" x 6.5" (165 mm x 165 mm)
 Plate thickness 1.0" & 0.75" (25 mm & 19 mm)



MOLDBOARD

Standard moldboard with replaceable end bits 12' x 29" x 1" (3 658 mm x 737 mm x 25 mm)
 Blade material SAE 1050 high carbon steel
 Edge through hardened 6" x 5/8" boron steel (152 mm x 16 mm)

Bolt spacing 6" (152 mm)
 - drilling size 5/8" (16 mm) bolts
 Slide rails supported by DURAMIDE™ bearings.



BLADE RANGE: MOVEABLE BLADE CONTROL SYSTEM

(Dimensions shown with standard moldboard)

	LEFT	RIGHT
Reach outside tires - articulated frame	120.0" (3 048 mm)	119.5" (3 035 mm)
Reach outside tires - straight frame	79.5" (2 019 mm)	79" (2 007 mm)
Blade slide	26.5" (673 mm)	26.5" (673 mm)
Circle side shift	30.5" (775 mm)	29.5" (749 mm)
Maximum bank sloping angle	90°	90°
Blade ground clearance	17.2" (437 mm)	
Blade cutting depth	31.5" (800 mm)	
Blade tilt range	44° forward	2.5° back

Superior blade mobility permits steep ditch cutting angles and back sloping outside overall machine width.



CAB & CONTROLS



All controls and gauges are housed in the fully adjustable steering pedestal and right hand console. Located in the pedestal head are the engine oil pressure, coolant temperature and fuel level gauges, transmission gear indicator and a three level electronic monitoring display. Pedestal located switches include: differential lock/unlock, independent moldboard floats (optional) and combination turn signal, hazard lights, and high beam headlight switch. Heater and wiper/washer controls, lighting and accessory switches are grouped in the operator's right hand console. This console also contains the ignition key and access to the circuit breaker panel. An accelerator/decelerator foot pedal and slider type hand throttle are standard equipment. Outside mounted rear view mirrors (L&R) are standard. Interior operator noise level ranges from 78 to 81 dB(A) per ISO 6394 (enclosed cab).

CAB OPTIONS

- High capacity heater/air conditioner c/w adjustable vents, temperature control and 3 speed fan
- Fully adjustable, suspension seat
- Lower opening vent windows
- Rear windshield wipers and washers
- Lower front window wipers and washers
- Modular, 24 volt radio and cassette player with remote control
- Operator Convenience Package (lunch box, steel vacuum bottle and holder, ashtray)
- 24 volt to 12 volt convertor for electrical accessories or two way radio installations

FULL HEIGHT CAB WITH ROPS INSIDE DIMENSIONS

Height 74.0" (1 880 mm)
 Width @ controls 56.0" (1 422 mm)
 Depth @ controls 55.5" (1 410 mm)

An optional Low Profile Cab is available with an inside height of 62" (1 575 mm). All Volvo Grader cabs and canopies are designed to meet or exceed SAE J1040 APR. 88, ISO 3471/1-1986(E), and 86/295/EEC ROPS requirements. The seatbelt is 2" (51 mm) wide and meets SAE J386 JUNE 93; ISO 6683-1981(E). A cushioned vinyl covered bucket seat with fore & aft and height adjustment is standard.



CAPACITIES

	U.S.Gal.	Imp.Gal.	Litres
Fuel tank	100.0	83.3	378.5
Transmission	10.0	8.4	38.0
Final drive	6.0	5.0	23.0
Tandems (each)	26.4	22.0	100.0
Hydraulic oil tank	23.8	19.8	90.0
Coolant antifreeze protection to -58° F (-50° C) approx	13.2	11.0	50.0
Engine oil	9.0	7.5	34.0



LOAD SENSING HYDRAULICS

Closed center hydraulic system senses load requirements and maintains system pressure 250 psi (17,25 Bar) above the load pressure.

When hydraulic pressure is not required, system pressure is only 90 psi (6,2 Bar).

System features industry standard control arrangement c/w low effort, feathering type, short throw levers located on a fully adjustable steering pedestal.

System incorporates lock valves to prevent cylinder drift under load in the following circuits: blade lift, moldboard tilt, circle shift, wheel lean, articulation and scarifier. All hoses and fittings are equipped with o-ring seals.

Pump design features include cast iron end covers and center housing, and one piece gear and shaft assembly to ensure reliability and long service life.

Maximum pressure 2,500 psi (172 Bar)
 Output at 2100 RPM 0-48.3 gpm (0-183 lpm)
 Filtration 7 micron spin-on type



ATTACHMENTS

A Frame 700 lb (318 kg)

SNOW

Hydraulic Wing

- high bench 4,800 lb (2 177 kg)
 - low bench 4,000 lb (1 814 kg)
 One Way Snow Plow 2,350 lb (1 065 kg)

Snow Wing

- front mounted 2,900 lb (1 315 kg)
 - rear mounted 3,100 lb (1 406 kg)

V Snow Plow

- 9' (2 743 mm) 2,500 lb (1 134 kg)
 - 10' (3 042 mm) 2,650 lb (1 202 kg)

EARTH

Dozer Blade

- 8' (2 438 mm) 1,600 lb (725 kg)
 - 9' (2 743 mm) 1,650 lb (748 kg)

Push Block 1,125 lb (510 kg)

Ripper/Scarifier, rear 2,625 lb (1 190 kg)

Scarifier with 11 teeth 1,725 lb (782 kg)

Windrow Eliminator 1,300 lb (590 kg)

DIMENSIONS

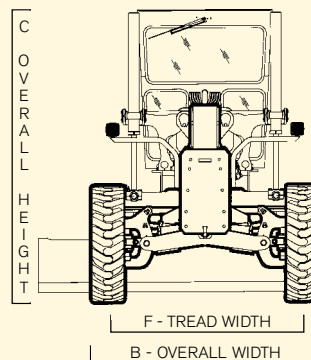
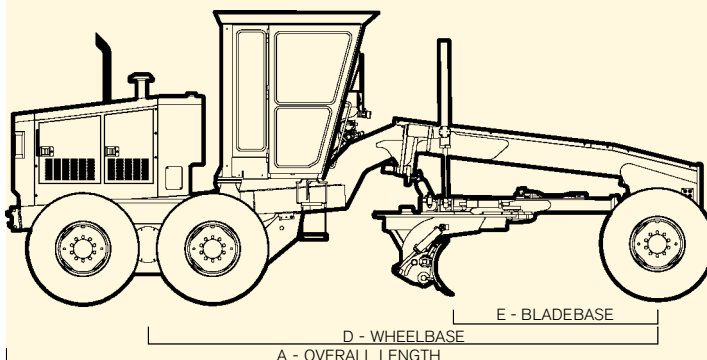

A Overall length 28'4" (8 636 mm)
 B Overall width 8'4" (2 540 mm)
 C Overall height 11'2" (3 404 mm)
 - with Low Profile Cab 10'2" (3 099 mm)
 D Wheelbase 20'6" (6 248 mm)
 E Bladebase
 - ISO 7134 8'11" (2 718 mm)
 F Tread width 7'0" (2 136 mm)

STANDARD FEATURES
Operator controlled, lock/unlock differential final drive
4 wheel, crossover, dual braking system with reserve power assist
Hand operated park brake with operator warning alarm and indicator
Fully sequential, direct drive, powershift 8400 transmission, with transmission guard
13.5" (343 mm) diameter, 4 plate, full oil master clutch
Moveable Blade Control System for optimum blade mobility
Full front and rear frame sections designed to absorb shock loading of rear attachments
Cab halogen headlights with dimmer includes directional and hazard lights
Circle drive cushion valve protects against impact damage
Hardened circle teeth cut on outside of circle for maximum turning power
Hardened circle drive pinions for maximum pinion life
Isolation mounted cab, transmission and engine for reduced noise and vibration
Adjustable steering pedestal with tilt head for maximum operator comfort
Gauges include: coolant temperature, engine oil pressure, fuel, hourmeter, dash mounted air cleaner service indicator, articulation angle indicator, three level electronic monitoring system - M4 - with visual and audible warnings
Load sensing, closed center hydraulic system with short throw, low effort control levers. Hydraulically operated blade lift, circle turn, moldboard slide and tilt, circle shift and wheel lean functions
Feathering type controls for precise blade adjustments
100 gallon fuel capacity
DURAMIDE™ wear strips on circle guide and clamp plates prevent metal-to-metal contact for maximum service life
Hinged radiator guard for easy trash clean out
Backup lights
Backup alarm with automatic volume level
Painted High Gloss Volvo Yellow and Gray
Lockable tool box with storage space for scarifier shanks
Engine side panels c/w locks
Left and right outside rear view mirrors

OPTIONAL EQUIPMENT	lb	Kg
Accumulators - blade lift (2) 130 59		
Air conditioner - 29,000 BTU		
- HFC-134a (non-CFC refrigerant) 130 59		
Brush guards 40 18		
Cab		
- Canopy shell with ROPS - deduct... (200) (91)		
- FOPS protection for ROPS cabs 220 100		
- Low Profile Cab		
with ROPS - deduct (200) (91)		
Cab heater - 49,000 BTU - with cab		
pressurizer and replaceable filter 30 14		
Cab pressurizer/filter 14 6		
Defroster fans 3 1		
Engine block heater 3 1		
Engine precleaner - Turbo II 6 3		
Exhaust aspirated precleaner 6 3		
Ether cold start 10 4		
Exhaust rain cap - -		
Fan - blower type		
(suction type is standard) 0 0		
First user lifetime frame warranty 0 0		
Float control - Right and Left		
independent, electric 15 7		
Hydraulic manifold cover 10 4		
Hydraulic tank heater 3 1		
24 volt radio/cassette player 6 3		
Lights		
- Beacon (amber or blue) 10 4		
- Clearance lights front & rear 2 1		
- Directional signals - -		
- Front mounted plow lights - 2		
- high mount 120 54		
- low mount 100 45		
- Headlights with dimmer switch 0 0		
- Moldboards lights - 2 2 1		
- Rear flood lights - 2 2 1		
- Snow wing lights - 2 2 1		
Machine Monitor Plus system - M044.. 0 0		
(Audible and visual warnings for transmission and hydraulic filter restriction, low engine oil pressure, high coolant temperature, high transmission temperature, and low transmission clutch pressure)		
Moldboards		
- 13' x 29" x 1" (3 962 mm x 737 mm x 25 mm) 380 172		
- 14' x 29" x 1" (4 267 mm x 737 mm x 25 mm) 300 136		

OPTIONAL EQUIPMENT (continued)	lb	Kg
Moldboard extensions		
R & L - 2' (610 mm) 200 91		
Moldboard edges - Carbide 3/4" x 5" (19 mm x 127 mm) - -		
100 amp alternator 0 0		
Operator convenience package		
- lunch box, steel vacuum bottle and holder, ashtray 10 5		
Paint - custom colors - -		
Polar protection 0 0		
Radiator shutters - hinged 10 4		
Reflectors - rear - -		
Remote lube manifold for articulation cylinders 0 0		
Remote valve for attachments		
- 3 or 5 bank 25 11		
Rim locks included with 3 piece rims 0 0		
Sideshift accumulator 45 20		
Supplemental steering (power assisted) meets SAE J53 OCT.84 61 28		
Suspension seat 55 25		
Tie down brackets 100 45		
Tires		
-14:00 x 24, 12 PR, G-2,		
10" (254 mm) multi-piece rims 120 54		
-17.5 x 25, 12 PR, L-2,		
14" (356 mm) rims 942 428		
-16:00 x 24, 12 PR, G-2		
10" (254 mm) rims 1,452 659		
Tool kit - -		
Transmission sump heater - -		
Tropical protection - -		
Vandalism protection 8 4		
Wheel weights front or rear - each 250 113		
Window - opening - lower front - -		
Window - opening sliders - left/right - -		
Wiper and washer - front - -		
Wiper and washer - rear - -		
Wiper and washer - lower front - -		

Your safety and the safety of those around you depends on using care and judgement when operating and servicing your grader. Do not operate the grader until you read and understand the warnings and instructions in the operator's manual. Volvo Motor Graders Limited is an ISO 9001 and 14001 registered company. www.volvo.com

Under our policy of continuous product development and improvement, we reserve the right to change specifications and design without prior notice. The illustrations do not necessarily show the standard version of the machine.

