

VOLVO MOTOR GRADER G720 / G720 VHP

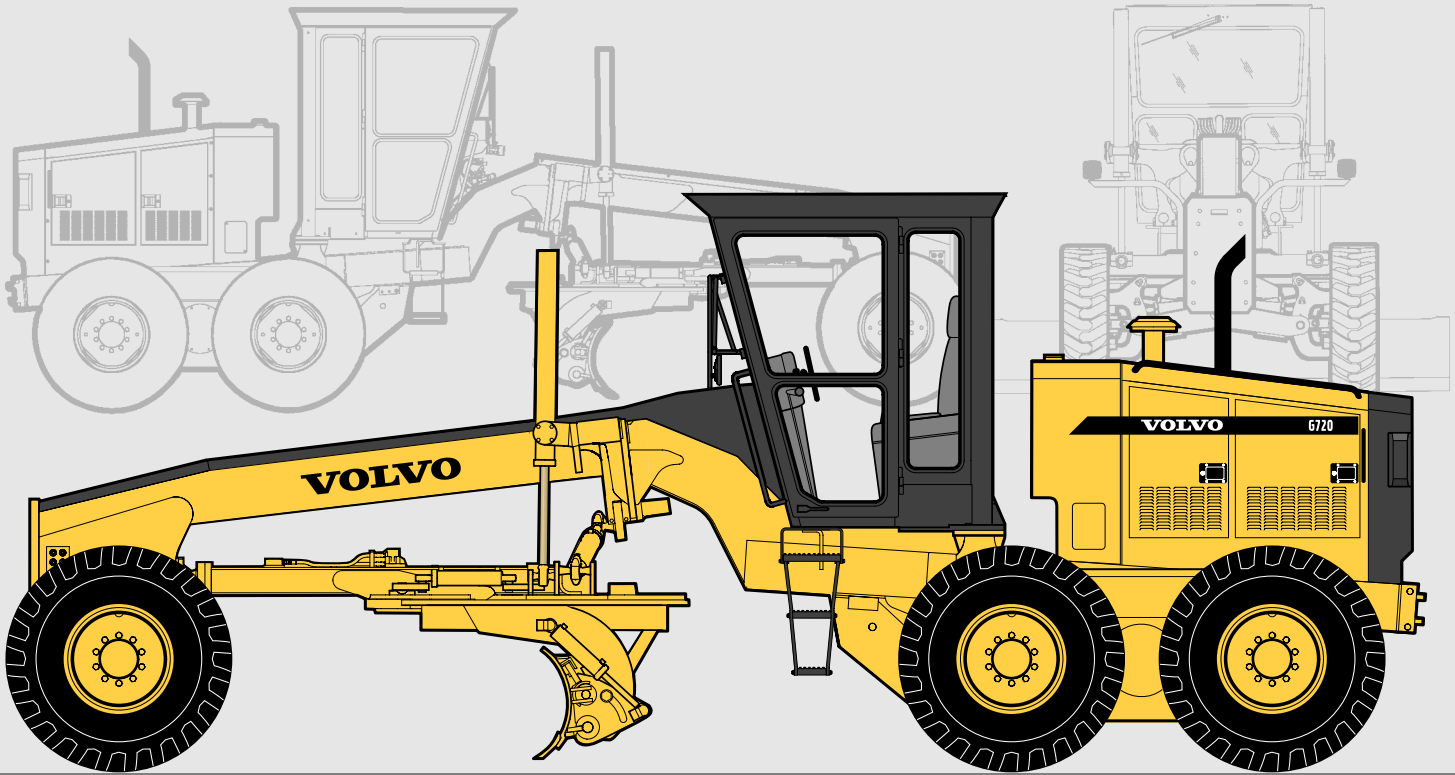

KEY FEATURES:

- 8400 fully sequential direct drive powershift transmission with 13.5" (343 mm) clutch
- Choice of fully enclosed, quiet, comfortable ROPS cab in full height or low profile configuration, or ROPS canopy
- Moveable Blade Control System
- Load sensing, closed center hydraulic system
- Fully adjustable, low effort controls
- Full front and rear frame sections for all attachment applications
- Single lever transmission control with "Smart Shifter" feature
- Hydraulically Boosted Dual Braking System with reserve power assist
- Heavy duty lock/unlock differential
- Three level electronic operator warning system
- 12' (3 658 mm) moldboard
- Full range of front and rear mounted attachments

MODEL	G720	G720 VHP
Configuration	Articulated Frame	Articulated Frame
Engine	Cummins 6C8.3	Cummins 6C8.3
Output (SAE J1349)	160 hp (120 kW)	170-195 hp (127-145 kW)
Base weight	32,570 lb (14 775 kg)	32,570 lb (14 775 kg)
Blade down pressure	16,717 lb (7 583 kg)	16,717 lb (7 583 kg)
Blade pull	20,657 lb (9 370 kg)	20,657 lb (9 370 kg)

VOLVO



BASE OPERATING WEIGHT (Standard Equipment)

Weights shown include full cab with ROPS, all operating fluids and operator.

G720 / G720 VHP

Total 32,570 lb (14 774 kg)
On front wheels 9,615 lb (4 361 kg)
On rear wheels 22,955 lb (10 415 kg)

Weight adjustments for various options are listed.

Typically equipped operating weight: includes 14' x 25" x 7/8" (4 267 mm x 635 mm x 22 mm) moldboard and scarifier.

G720 / G720 VHP 34,300 lb (15 560 kg)



PRODUCTIVITY (Standard Equipment)

Maximum blade pull (no wheel slip, 0.9 traction co-efficient) 20,657 lb (9 370 kg)

Blade down pressure

- cutting capability

(ISO 7134) 16,717 lb (7 583 kg)

Blade down pressure is the maximum downward force which may be applied at the cutting edge.



ENGINE DATA

G720

Make/Model Cummins 6C8.3

Type 4 Cycle, Turbocharged

No. of cylinders In Line 6

Bore & stroke ... 4.49" x 5.32" (114 mm x 135 mm)

Displacement 504.5 cu in (8,27 L)

Rated gross brake horsepower

@ 2200 RPM 170 hp (127 kW)

Rated net brake horsepower

@ 2200 RPM 160 hp (120 kW)

Torque @ 1500 RPM 560 lb.ft (759 N.m)

Torque rise (Net) 44%

G720 VHP

Make/Model Cummins 6C8.3

Type 4 Cycle, Turbocharged

No. of cylinders In Line 6

Bore & stroke ... 4.49" x 5.32" (114 mm x 135 mm)

Displacement 504.5 cu in (8,27 L)

Rated gross brake horsepower @ 2200 RPM

- Gears forward 1, 2 and

Reverse 1 183 hp (136 kW)

- Gears forward 3-8 and

Reverse 2-4 205 hp (153 kW)

Rated net brake horsepower @ 2200 RPM

- Gears forward 1, 2 and

Reverse 1 170 hp (127 kW)

Torque @ 1500 RPM 500 lb.ft (678 N.m)

Torque rise (Net) 20%

- Gears forward 3-8 and

Reverse 2-4 195 hp (145 kW)

Torque @ 1500 RPM 636 lb.ft (862 N.m)

Torque rise (Net) 36%

Engine equipped with a two stage, dual element, dry type air cleaner with evacuator and dash mounted service indicator. 24 volt starting and electrical system with 75 amp (1800 watt) brushless alternator with internal voltage regulator. Two heavy duty 12 volt maintenance free batteries with 625 cold cranking amps (CCA) and 180 minutes reserve capacity per battery. 900 CCA batteries available optionally. System includes battery disconnect.

Performance: Rated net brake horsepower SAE standard J1349/ISO 3046-2 conditions with water pump, fuel system, air cleaner, muffler, alternator, and cooling fan.



TRANSMISSION

Make/Model Volvo 8400
Fully sequential, direct drive, powershift transmission. Engine cannot be started if transmission is in gear. Single lever transmission controller provides electronic self-diagnostics. The flywheel mounted, multi-disc master clutch is oil cooled for long life.

Ground speeds at 2200 RPM with standard tires:

Forward			Reverse		
Gears	mph	km/h	Gears	mph	km/h
1	2.8	4.4	1	2.8	4.4
2	3.9	6.2	2	5.3	8.5
3	5.3	8.5	3	10.5	16.9
4	7.5	11.9	4	20.4	32.7
5	10.5	16.9			
6	14.7	23.6			
7	20.4	32.7			
8	28.5	45.7			

Transmission guard is standard equipment and is hinged for easy access.



DIFFERENTIAL / FINAL DRIVE

Make/Model Volvo SR30
Single reduction final drive with an operator controlled lock/unlock differential. Rear axles are case hardened, supported on double row spherical roller bearings.



TANDEMS

Oscillating tandem case has internal gusseting for maximum torsional strength. Field proven split ring/flanged sleeve tandem mounting and 1" (25 mm) thick inner wall resists flexing from side loading during severe applications.

Depth	24.50"	(622 mm)
Width	8.25"	(210 mm)
Thickness - inner wall	1.00"	(25 mm)
- outer wall	0.75"	(19 mm)
Center distance	61.50"	(1 562 mm)
Drive chain pitch	2.00"	(51 mm)
Oscillation	± 15°	



BRAKES

Service Brakes Foot operated
Fade resistant, hydraulically actuated, oil disc service brakes located at the 4 tandem wheels are self-adjusting, fully sealed and maintenance free. System features crossover dual braking circuits for even braking on both sides of the grader. Includes reserve power assist and operator warning system (visual and audible).

Parking Brake Hand operated
Independent, disc type hand brake on transmission output shaft and effective on all 4 tandem drive wheels. Includes visual and audible operator warning system for parking brake on, transmission in gear condition.

Braking systems to SAE Recommended Practice J1473 OCT. 90, and J1152 APR. 80; ISO 3450-1993-01-28. Volvo uses asbestos free brake components.



WHEELS & TIRES (Standard Equipment)

Tire size 14:00 x 24, G-2
Ply rating (PR) 12
Rim size 10.0" (254 mm)
Bolt-on rims are interchangeable between the front wheels and the tandem wheels.



FRONT AXLE

Type Fully welded steel truss, gusseted for torsional strength, oscillates on a single 3.5" (89 mm) diameter center pivot pin

Wheel lean 18° R & L

Oscillation 16° up and down

Ground clearance 24.0" (610 mm)

A single 4" (102 mm) diameter wheel lean cylinder with lock valve is standard equipment. Two 3" (76 mm) diameter wheel lean cylinders and lock valve are available optionally.



STEERING

Hydraulic power front wheel steering incorporating two steering cylinders. Meets SAE J1511 OCT. 90 with optional supplemental steering.

Minimum turning radius using articulation, front axle steering, wheel lean

and unlocked differential 25'6" (7 772 mm)

Steering arc 72°

Frame articulation angle 22°

Articulation lock standard



FRAME

Full front and rear frame sections

Front: Fully welded box section. Dual sloped front frame provides excellent forward visibility.

Minimum dimensions of

box section 10.5" x 14.0" (267 mm x 356 mm)

Plate thickness 0.75" (19 mm)

Vertical section modulus

at arch 119 cu in (1 950 cm³)

minimum 101.5 cu in (1 663 cm³)

maximum 212 cu in (3 474 cm³)

Linear weight - minimum-maximum

107.1 - 232.5 lb/ft (159.4 - 346.0 kg/m)

Rear: Full rear frame permits modular powertrain mounting for ease of service and simplifies attachment mounting.

Minimum dimensions of

rear frame 4.0" x 10.0" (102 mm x 254 mm)

Plate thickness 0.5" (13 mm)



ARTICULATION

Twin 4.5" (114 mm) hydraulic cylinders articulate the frame 22° right and left. Anti-drift lock valve.



CIRCLE

Hardened teeth, cut on the outside of the circle for maximum leverage and minimum wear. Circle is fabricated from high tensile steel and all running surfaces are precision machined.

The circle is held in place at six points by three adjustable clamp plates and three adjustable guide shoes, providing optimum circle support and load distribution. The primary set of clamp and guide shoes is located at the front of the circle where greatest loading occurs. DURAMIDE™ faced clamp and guide shoes prevent metal-to-metal contact and provide maximum service life.

DURAMIDE™ is a synthetic bearing material that maximizes service life and reduces circle system maintenance requirements.

Diameter 66.25" (1 683 mm)

Thickness 1.25" (32 mm)

Adjustable guide shoes 3

Adjustable clamp plates 3



CIRCLE DRIVE

The Volvo dual cylinder circle drive system uses direct acting hydraulic power for exceptional turning and holding capability under full load. The circle drive system uses hardened drive pinions and is fully protected against impact damage by an overload cushion valve as standard equipment.

Hydraulic drive cylinders	2
Points of leverage	2
Rotation	360°



DRAWBAR

Fully welded box section. Narrow "T" design permits optimum visibility to the work area. Drawbar ball stud provides an adjustment to compensate for different tire sizes. Blade lift cylinder anchors are straddle mounted on drawbar to provide maximum strength and support.

Dimensions of box section	6.5" x 6.5" (165 mm x 165 mm)
Plate thickness.....	1.0" & 0.75" (25 mm & 19 mm)



MOLDBOARD

Standard moldboard with replaceable end bits

12' x 25" x 7/8" (3 658 mm x 635 mm x 22 mm)

Blade material

SAE 1050 high carbon steel

Edge: through hardened

6" x 5/8" boron steel (152 mm x 16 mm)

Bolt spacing

6" (152 mm)

- drilling size

5/8" (16 mm) bolts

Slide rails supported with DURAMIDE™ bearings.



BLADE RANGE: MOVEABLE BLADE CONTROL SYSTEM

(Dimensions shown with standard moldboard)

	LEFT	RIGHT
--	------	-------

Reach outside tires - articulated frame	120.0" (3 048 mm)	119.5" (3 035 mm)
Reach outside tires - straight frame	79.5" (2 019 mm)	79.0" (2 007 mm)
Blade slide	26.5" (673 mm)	26.5" (673 mm)
Circle side shift	30.5" (775 mm)	29.5" (749 mm)
Maximum bank sloping angle	90°	90°
Blade ground clearance	17.5" (445 mm)	
Blade cutting depth	32.0" (813 mm)	
Blade tilt range	44° forward	6.5° back

Superior blade mobility permits steep ditch cutting angles and back sloping outside overall machine width.



CAB & CONTROLS



All controls and gauges are housed in the fully adjustable steering pedestal and right hand console. Located in the pedestal head are the engine oil pressure, coolant temperature and fuel level gauges, transmission gear indicator and a three level electronic monitoring display. Pedestal located switches include: differential lock/unlock, independent moldboard floats (optional) and combination turn signal, hazard lights, and high beam headlight switch. Heater and wiper/washer controls, lighting and accessory switches are grouped in the operator's right hand console. This console also contains the ignition key and access to the circuit breaker panel. An accelerator/decelerator foot pedal and slider type hand throttle are standard equipment. Outside mounted rear view mirrors (L&R) are standard. Interior operator noise level ranges from 78 to 81 dB(A) per ISO 6394 (enclosed cab).

CAB OPTIONS

- High capacity heater/air conditioner c/w adjustable vents, temperature control and 3 speed fan
- Fully adjustable, suspension seat
- Lower opening vent windows
- Rear windshield wipers and washers
- Lower front window wipers and washers
- Modular, 24 volt radio and cassette player with remote control
- Operator Convenience Package (lunch box, steel vacuum bottle and holder, ashtray)
- 24 volt to 12 volt convertor for electrical accessories or two way radio installations

FULL HEIGHT CAB WITH ROPS INSIDE DIMENSIONS

Height	74.0" (1 880 mm)
Width @ controls	56.0" (1 422 mm)
Depth @ controls	55.5" (1 410 mm)

An optional Low Profile Cab is available with an inside height of 62" (1 575 mm). All Volvo Grader cabs and canopies are designed to meet or exceed SAE J1040 APR. 88, ISO 3471/1-1986(E), and 86/295/EEC ROPS requirements. The seatbelt is 2" (51 mm) wide and meets SAE J386 JUNE 93; ISO 6683-1981(E). A cushioned vinyl covered bucket seat with fore & aft and height adjustment is standard.



CAPACITIES

	U.S.Gal.	Imp.Gal.	Litres
Fuel tank	100.0	83.3	378.5
Transmission	10.0	8.4	38.0
Final drive	6.0	5.0	23.0
Tandems (each)	26.4	22.0	100.0
Hydraulic oil tank	23.8	19.8	90.0
Coolant antifreeze protection to -58° F (-50° C) approx ...	12.4	10.3	47.0
Engine oil	5.0	4.2	19.0



LOAD SENSING HYDRAULICS

Closed center hydraulic system senses load requirements and maintains system pressure 250 psi (17,25 Bar) above the load pressure.

When hydraulic pressure is not required, system pressure is only 90 psi (6,2 Bar).

System features industry standard control arrangement c/w low effort, feathering type, short throw levers located on a fully adjustable steering pedestal.

System incorporates lock valves to prevent cylinder drift under load in the following circuits: blade lift, moldboard tilt, circle shift, wheel lean, articulation and scarifier (optional). All hoses and fittings are equipped with o-ring seals.

Pump design features include cast iron end covers and center housing, and one piece gear and shaft assembly to ensure reliability and long service life.

Maximum pressure	2,500 psi (172 Bar)
Output at 2200 RPM	0-50.5 gpm (0-191 lpm)
Filtration	7 micron spin-on type



ATTACHMENTS

"A" Frame	700 lb (318 kg)
SNOW	
Hydraulic Wing	
- high bench	4,800 lb (2 177 kg)
- low bench	4,000 lb (1 814 kg)
One Way Snow Plow	2,350 lb (1 065 kg)
Snow Wing	
- rear mounted	3,100 lb (1 406 kg)
"V" Snow Plow	
- 9' (2 743 mm)	2,500 lb (1 134 kg)
- 10' (3 042 mm)	2,650 lb (1 202 kg)
EARTH	
Dozer Blade	
- 8' (2 438 mm)	1,600 lb (725 kg)
- 9' (2 743 mm)	1,650 lb (748 kg)
Push Block	1,125 lb (510 kg)
Ripper/Scarifier, rear	2,625 lb (1 190 kg)
Scarifier with 11 teeth	1,725 lb (782 kg)
Windrow Eliminator	1,300 lb (590 kg)

DIMENSIONS

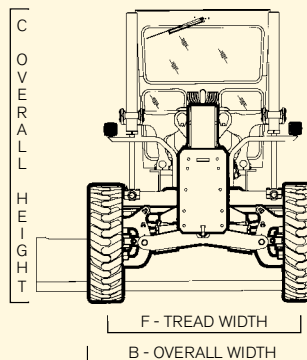
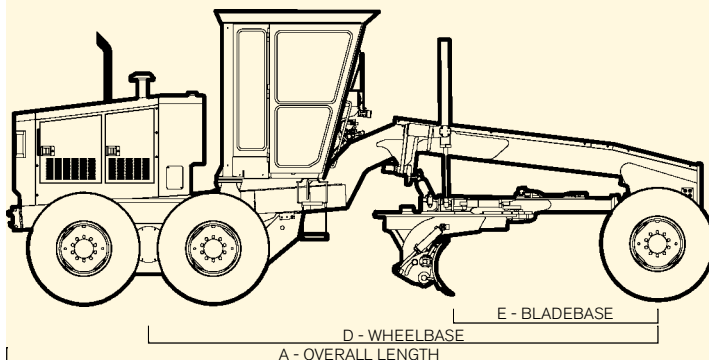

A	Overall length	27'10" (8 484 mm)
B	Overall width	8'4" (2 540 mm)
C	Overall height	11'2" (3 404 mm)
	- with Low Profile Cab	10'2" (3 099 mm)
D	Wheelbase	20'0" (6 096 mm)
E	Bladebase	
	- ISO 7134	8'6" (2 591 mm)
F	Tread width	6'10" (2 083 mm)

STANDARD FEATURES

Operator controlled, lock/unlock differential final drive
 4 wheel, crossover, dual braking system with reserve power assist
 Hand operated park brake with operator warning alarm and indicator
 Fully sequential, direct drive, powershift 8400 transmission, with transmission guard
 13.5" (343 mm) diameter, 4 plate, full oil master clutch
 Moveable Blade Control System for optimum blade mobility
 Full front and rear frame sections designed to absorb shock loading of rear attachments
 Circle drive cushion valve protects circle drive against impact damage
 Hardened circle teeth cut on outside of circle for maximum turning power
 Hardened circle drive pinions for maximum wear resistance
 Isolation mounted cab, transmission and engine for reduced noise and vibration
 Adjustable steering control pedestal with tilt head for maximum operator comfort
 Gauges include: coolant temperature, engine oil pressure, fuel, hourmeter, dash mounted air cleaner service indicator, articulation angle indicator, three level electronic monitoring system - M4 - with visual and audible warnings
 Load sensing, closed center hydraulic system with short throw, low effort control levers. Hydraulically operated blade lift, circle turn, moldboard slide and tilt, circle shift and wheel lean functions
 Feathering type controls for precise blade adjustments
 100 gallon fuel capacity
 DURAMIDE™ wear strips on circle guide and clamp plates prevent metal-to-metal contact for maximum service life
 Hinged radiator guard for easy trash clean out
 Backup lights
 Backup alarm with automatic volume levels
 Painted High Gloss Volvo Yellow and Gray
 Lockable tool box with storage space for scarifier shanks
 Engine side panels c/w locks
 Left and right outside rear view mirrors

OPTIONAL EQUIPMENT

	lb	Kg
Accumulators - blade lift (2)	130	59
Air conditioner - 29,000 BTU		
- HFC-134a (non-CFC refrigerant)	130	59
Brush guards	40	18
Cab		
- Canopy shell with ROPS - deduct... (200)	(91)	(91)
- FOPS protection for ROPS cabs	220	100
- Low Profile Cab		
with ROPS - deduct	(200)	(91)
Cab heater - 49,000 BTU - with cab		
pressurizer and replaceable filter	30	14
Defroster fans	3	1
Dual leaning wheel cylinder	25	11
Engine block heater	3	1
Engine precleaner - Turbo II	6	3
Exhaust aspirated precleaner	6	3
Ether cold start	10	4
Exhaust rain cap	-	-
Fan - blower type		
(suction type is standard)	0	0
First user lifetime frame warranty	0	0
Float control - Right and Left		
independent, electric	15	7
Hydraulic manifold cover	10	4
Hydraulic tank heater	3	1
24 volt radio/cassette player	6	3
Lights		
- Beacon (amber or blue)	10	4
- Clearance lights front & rear	2	1
- Front mounted plow lights - 2		
- high mount	120	54
- low mount	100	45
- Headlights with dimmer switch	0	0
- Moldboards lights - 2	2	1
- Rear flood lights - 2	2	1
- Snow wing lights - 2	2	1
Machine Monitor Plus system - M044 ..	0	0
(Audible and visual warnings for transmission and hydraulic filter restriction, low engine oil pressure, high coolant temperature, high transmission temperature, and low transmission clutch pressure)		

OPTIONAL EQUIPMENT (continued)

	lb	Kg
Moldboards		
- 14' x 25" x 7/8"		
(4 267 mm x 635 mm x 22 mm)	280	127
Moldboard extensions		
R & L - 2' (610 mm)	200	91
Moldboard edges - Carbide 3/4" x 5"		
(19 mm x 127 mm)	-	-
100 amp alternator	0	0
Operator convenience package		
- lunch box, steel vacuum bottle		
and holder, ashtray	10	5
Paint - custom colors	-	-
Polar protection	0	0
Radiator shutters - hinged	10	4
Reflectors - rear	-	-
Remote lube manifold for articulation		
cylinders	0	0
Remote valve for attachments		
- 3 or 5 bank	25	11
Sideshift accumulator	45	20
Supplemental steering (power		
assisted) meets SAE J53 OCT.84	61	28
Suspension seat	55	25
Tie down brackets	100	45
Tires		
- 14:00 x 24, 12 PR G-2,		
10" (254 mm) multi-piece rims	450	204
- 17.5" x 25", 12 PR L-2,		
14" (356 mm) rims	1,032	468
Rim locks included with 3 piece rims ...	0	0
Tool kit	-	-
Transmission sump heater	-	-
Tropical protection	-	-
Vandalism protection	8	4
Wheel weights front or rear - each	250	113
Window - opening - lower front	-	-
Window - opening sliders - left/right	-	-
Wiper and washer - front	-	-
Wiper and washer - rear	-	-
Wiper and washer - lower front	-	-

Your safety and the safety of those around you depends on using care and judgement when operating and servicing your grader. Do not operate the grader until you read and understand the warnings and instructions in the operator's manual. Volvo Motor Graders Limited is an ISO 9001 and 14001 registered company. www.volvo.com

Under our policy of continuous product development and improvement, we reserve the right to change specifications and design without prior notice. The illustrations do not necessarily show the standard version of the machine.

VOLVO

Volvo Construction Equipment Group

Ref. No. 21 2 434 1004
 Printed in Canada 1/2001 - 10,0

GDR