

Euclid R40C



MAXIMUM GMW
73 482 KG

MAXIMUM PAYLOAD
40 TONNE

CUMMINS QUANTUM ENGINE
525 HORSEPOWER
EMISSION CERTIFIED

COMMAND CAB III

ALL-HYDRAULIC BRAKING
WET DISC BRAKES

SWING-OUT GRILLE

CONTRONIC II
MONITORING SYSTEM

AUTOMATIC
TRANSMISSION
TRIM BOOST SOFT SHIFT
TWO-SPEED REVERSE

ACCU-TRAC SUSPENSION
NEOCON STRUTS

LOW LOADING HEIGHT

RADIAL TIRES

EUCLID



ENGINE

Make	Cummins			
Model	QSK19-C525			
Type	4 Cycle			
Aspiration	Turbocharged/Aftercooled			
Rated Output	kW	bhp	392	525
(SAE @ 2100 rpm)				
Flywheel Output	kW	bhp	375	503
(SAE @ 2100 rpm)				
No. Cylinders	6			
Bore and Stroke	mm 159 x 159			
	6 1/4" x 6 1/4"			
Displacement	liters	in ³	18,9	1,150
Max. Torque	@ 1300 rpm			
	N•m	ft lb	2 407	1,775
Torque Rise	30%			
Starting	Electric			



TRANSMISSION

Allison M5600. Planetary type, full automatic shifting. Integral torque converter, with automatic lock-up in all ranges. Remote mounted. Six forward speeds, two reverse. Allison Transmission Commercial Electronic Control shift system. Trim Boost Soft Shift provides smooth shifting to help reduce operator fatigue.

Maximum Speeds @ governed engine speed

Gear	Ratio	STANDARD DIFF. 3.13:1		OPTIONAL DIFF. 2.81:1			
		Standard Planetary	Optional Planetary	Standard Planetary	Optional Planetary		
1	4.00	11,30	7.00	10,20	6.30	12,60	7.80
2	2.68	16,90	10.50	15,20	9.40	18,80	11.70
3	2.01	22,50	14.00	20,20	12.60	25,00	15.60
4	1.35	33,50	20.80	30,10	18.70	37,30	23.20
5	1.00	45,20	28.10	40,60	25.30	50,30	31.30
6	0.67	68,20	42.50	61,30	38.10	76,00	47.20
R1	5.12	8,90	5.50	8,00	5.00	9,90	6.20
R2	3.46	13,20	8.20	11,90	7.40	14,70	9.10



DRIVE AXLE

Full floating axle shafts, reduction provided by Euclid Model 2052 differential and single reduction planetary with balanced life gearing in each wheel to maximize gear life.

Optional Active Traction Control (ATC) with Electronic Downhill Speed Control (EDSC) available.

Ratios	STANDARD DIFF. 3.13:1		OPTIONAL DIFF. 2.81:1
	Standard Planetary	Optional Planetary	Standard Planetary
Differential	3.13:1	3.13:1	2.81:1
Planetary	5.25:1	6.00:1	5.25:1
Total Reduction	16.43:1	18.78:1	14.75:1



TIRES

Standard – Front and Rear		Rim Width	
18.00R33(**)E2/E3		mm	in
Optional tires, brands and treads available.		330	13



ELECTRICAL SYSTEM

Twenty-four volt lighting and accessories system. Seventy-five amp alternator with integral transistorized voltage regulator. Two 12-volt, heavy-duty batteries connected in series.

Standard CONTRONIC II monitoring and central warning system with built-in diagnostics. Standard Liquid Crystal Display.



LOAD CAPACITY

	m ³	yd ³
Struck (SAE)	20,5	26.8
Heap 3:1	25,0	32.7
Heap 2:1 (SAE)	27,4	35.8
	Tonne	Ton
*Payload depending on equipment	40.0	44.1

Note: Based on material density, Euclid will size an optional larger or smaller body to assure rated payload. Consult Euclid Market Support.



WEIGHTS

	kg	lb
Chassis with Hoists	23 698	52,245
Body	9 784	21,570
Net Machine Weight	33 482	73,815
Maximum Payload	40 000	88,185
Maximum GMW with Std. Tires [18.00R33(**)E2/E3] Including Options, 50% Fuel, Operator & Payload Not to Exceed	73 482	162,000

*Major Options

Approximate change in Net Machine Weight:		
Body Liners - complete - 400 BHN Steel	2 230	4,916

Weight Distribution

	FRONT	REAR
Empty	50.1%	49.9%
Loaded	33.0%	67.0%



STEERING SYSTEM

Closed-center, full-time hydrostatic power steering system using two double-acting cylinders, pressure limit with unload piston pump and brake actuation/steering system reservoir. Accumulator provides supplementary steering in accordance with SAE J1511 and ISO 5010. Tilt/telescopic steering wheel with 35 degrees of tilt and 57,15 mm 2.25" telescopic travel.

Steering Angle				42°
Turning Diameter (SAE)	m	ft	16,15	53.0
Steering Pump Output	l/m	gpm	95,8	25.3
Operating System Pressure	kPa	psi	18 961	2,750



HYDRAULIC SYSTEM

Two Euclid two-stage, double-acting cylinders, with cushioning in retraction, inverted and outboard-mounted. Separate Hoist/Brake Cooling reservoir and independent tandem gear pump. Control valve mounted on reservoir.

Body Raise Time	s		11.2	
Brake Cooling Pump Output (@ 2100 rpm)	l/m	g/m	200,3	52.9
Hoist Pump Output (@ 2100 rpm)	l/m	g/m	301,3	79.6
System Relief Pressure	kPa	psi	17 237	2,500



BRAKING SYSTEM

Brake system complies with ISO 3450 and SAE J1473.

All-hydraulic actuated braking system providing precise braking control and quick system response. The brake controller has a unique variable front to rear brake proportioning that maximizes the stopping performance under slippery road conditions without having to deactivate front brakes.

Service

All-hydraulic actuated front dry disc brakes, and rear wet disc brakes.

Front Axle - Dry Discs

Disc Diameter Each (2 discs/axle)	cm	in	67,3	26.5
Brake Surface Area	cm ²	in ²	4 129	640
Lining Area Per Axle	cm ²	in ²	1 394	216
Brake Pressure (Max.)	kPa	psi	15 859	2,300

Rear Axle - Oil-Cooled Wet Discs

Brake Surface Area Per Axle	cm ²	in ²	37 209	5,767
Brake Pressure (Max.)	kPa	psi	8 274	1,200

Optional Increased Capacity

Brake Surface Area Per Axle	cm ²	in ²	49 551	7,680
Brake Pressure (Max.)	kPa	psi	8 274	1,200

Secondary

Two independent circuits within the service brake system provide fully modulated reserve braking capability. System also incorporates automatic application when loss of pressure is detected.

Parking

Drum, two shoe internal expanding type mounted on transmission output shaft. Controlled by a toggle switch on the dash. Automatically applied if brake hydraulic pressure is lost.

Size	mm	in	305 x 127	12" x 5"
-------------	----	----	-----------	----------

Retarder

Foot operated valve controls all-hydraulic actuation of oil-cooled wet disc brakes on rear axle. System provides modulated pressure to rear brakes for constant speed control.

Capacity		kW	hp
Continuous		484	649
Intermittent		969	1,300



WET DISC BRAKE

The Euclid-designed wet disc brake is engineered for long service life even in the most extreme environments. The wet disc brakes are located on the rear axle and provide service braking, secondary braking, and retarding. The brakes are a multi-plate design and are continuously oil-cooled. The sealed design protects against environmental contamination for prolonged service life. The wet disc brake is designed with automatic retraction to prevent drag. Separate pedals activate the service braking and retarding functions.

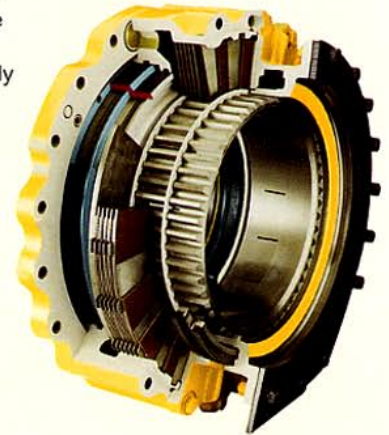

COMMAND CAB III

COMMAND CAB III integral ROPS/FOPS is standard in accordance with SAE J1040 (1994) and ISO 3471. Dimensions comply with SAE J154 (1992) and ISO 3411. Double-wall construction with 11 gauge outer steel panels lends itself to



a more structurally sound cab. Foam rubber lining material along with foam rubber-backed carpeting and multiple layered floor mat act to absorb sound and control interior temperature. A properly maintained cab from Euclid, tested with doors and windows closed per work cycle procedures in SAE J1166 (1990), results in an operator sound exposure L_{eq} (Equivalent Sound Level) of 79 dB(A). A three-point rubber iso-mount arrangement to the deck surface minimizes vibration to the operator compartment.

Excellent Serviceability. A removable front closure allows easy access to service brake valves and retarder valve. The upper dash utilizes four (4) removable panels that house gauges and customer options, each individually accessible. A removable closure located behind the seat provides easy access to the shifting control, CONTRONIC II, and all electrical junction points.

Comfort and Ease of Operation. A wrap-around style dashboard positions controls within easy reach and visual contact. A full complement of easy-to-read gauges, CONTRONIC II monitoring and warning system with Liquid Crystal Display (LCD), a spacious environment, six-way adjustable mechanical seat, tilt/telescopic steering wheel, filtered ventilation, door locks, and padded trainer seat, all contribute to operator convenience and comfort.

STANDARD EQUIPMENT

General

ACCU-TRAC suspension system	Hoist interlock
All hydraulic braking	Hoist tank sight gauge
Automatic transmission shifting	Load/dump brake
Body down indicator, mechanical	LED taillights
Body down cushioning	Mirrors right and left, hand adjustable
Body prop pins	Mud flaps
Body up speed restriction w/light	NEOCON suspension struts
Canopy spill guard	Park brake interlock
Continuous heated body	Radiator grill guard
Electric horns	Reverse alarm
Electric start	Rock ejector bars
Electronic engine controls	Steering accumulator
Fan guard	Steering tank sight gauge
Fenders	Swing-out grille
Fixed steering stops	Tires 18.00R33(**)E2/E3
Guard rails	Tow points, front/rear
Halogen lights	Transmission sight gauge
	Two-speed reverse

Cab

12-volt accessory connection	Integrated transmission diagnostics
Acoustical lining	Load counter
Air filtration/replaceable element	Service intervals
Ash tray	Throttle position
Cab interior light	Total engine hours
Cigar lighter	Total idle hours
Door locks	Voltmeter
Heater and defroster, 26,000 Btu	Mechanical suspension, 6 position seat
Integral ROPS/FOPS cab	Modular instrumentation
ISO decals	Quick connect test ports
ISO driver envelope	Roll down windows
Liquid Crystal Display* (CONTRONIC II)	Rubber floor mat
Body up	Safety glass
Boost pressure	Seat belt retractable (operator)
Clutch pressure	Sun visor
Distance traveled	Tilt/telescopic steering wheel
Engine oil pressure	Tinted glass, all windows
Fuel gauge	Trainer seat
Fuel pressure	Windshield washer
Gear selection	Windshield wiper, intermittent
Injector timing rail-pressure	
Intake manifold temperature	
Integrated engine diagnostics	

Gauges and Indicators

CONTRONIC II monitoring and alarm system, multi-function indicator lights:	Gauges:
Air filter restriction	Brake temperature
Alternator	Converter temperature
Body up	Coolant temperature
Brake oil temperature	Hour meter
Brake system low pressure	Speedometer
Central warning	Steering/brake pressure
Converter temperature	Tachometer
Coolant level	
Coolant temperature	
Do not shift	
Engine oil pressure	
Engine service	
Engine shutdown	
High beam indicator	
Hydraulic filter restriction	
Parking brake applied	
Steering filter restriction	
Steering pressure	
Steering temperature	
Transmission filter restriction	
Transmission malfunction	
Transmission oil pressure	
Turn signals/hazard	

Machine Lights

Back-up light (2)
Clearance lights (2)
Stop & tail (2)
Head-lights (4)
Turn signals and four-way flashers

OPTIONAL EQUIPMENT

Air conditioning	Front brake cut-off switch
Air suspension seat	HAULTRONIC II LOAD MONITORING SYSTEM
ACTIVE TRACTION CONTROL (ATC) w/ELECTRONIC DOWNHILL SPEED CONTROL (EDSC)	Hoodsides (rubber)
Body, heavy duty	High intensity headlights
Body liners (400 BHN) plates	High temperature cooling, 0.85:1 fan drive
Body sideboard extensions	Lube system, automatic
Canopy spill guard extension	Muffler, deck mounted
Cold start aid	Planetary, 6.00:1 ratio
Differential, 2.81:1 ratio	Radio & tape player
Driveline guard, front	Sound suppression package
Engine compartment lights	Starter lockout switch
Engine heater (oil & coolant)	Tires, (type & rating)
Extra reverse alarm	Transmission guard
Fast fueling	Unit sound suppression

* English, French, German, Spanish and Swedish Language selectable.

Standard and optional equipment may vary from country to country. Special options provided on request. Consult Euclid Market Support.

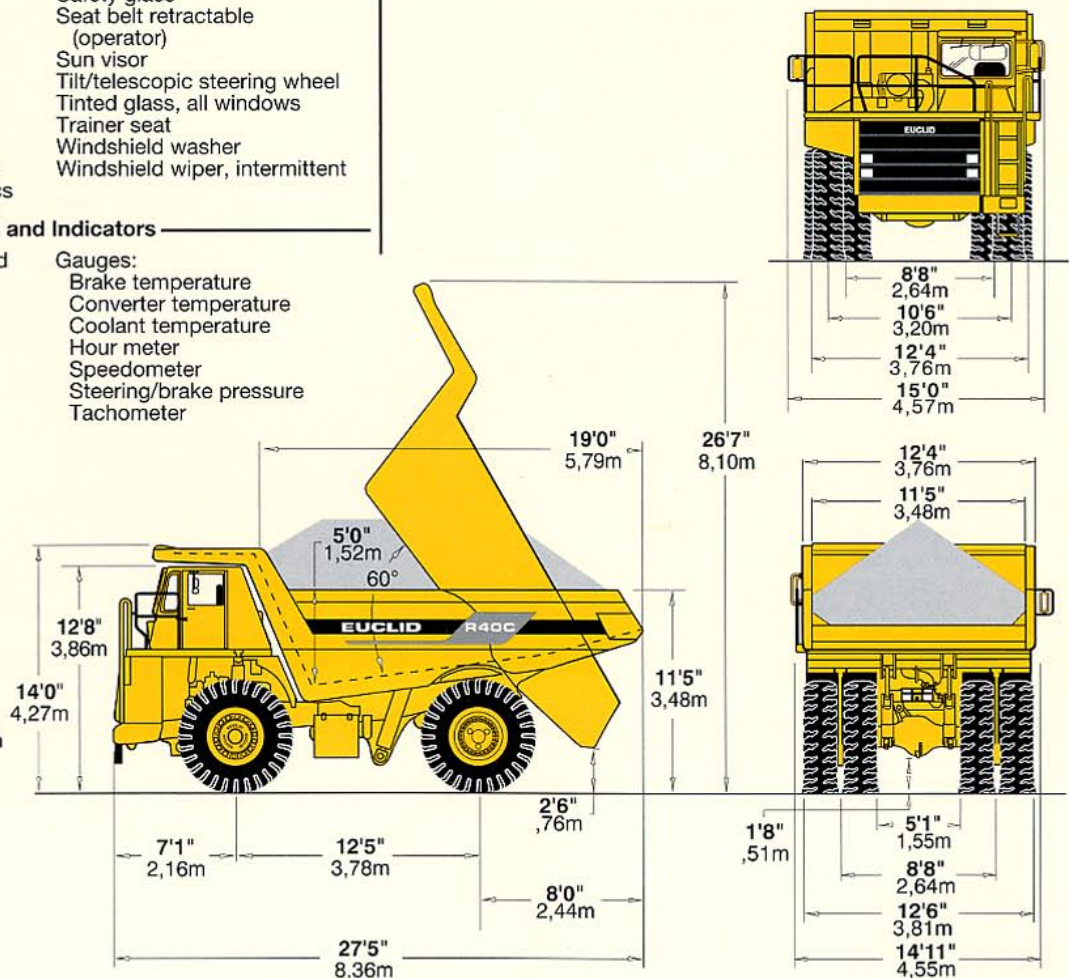



SUSPENSION

Front and Rear Suspension

For years, Euclid haulers have enjoyed an industry-wide reputation for superior suspension systems. That experience and knowledge has now been pushed to the next level, to develop the truly advanced ACCU-TRAC suspension for the R40C.

The new ACCU-TRAC suspension system features independent trailing arms for each front wheel with NEOCON struts, containing energy absorbing gas and compressible NEOCON-E™ fluid, mounted between the king pins and the frame. This arrangement allows a wider front track that provides a better ride, improved stability and a reduced turning circle. The rear axle housing has an A-frame mounting. The rear NEOCON struts are mounted in a more vertical position which allows for purer axial loading and reduces the tractive and braking forces transmitted to the

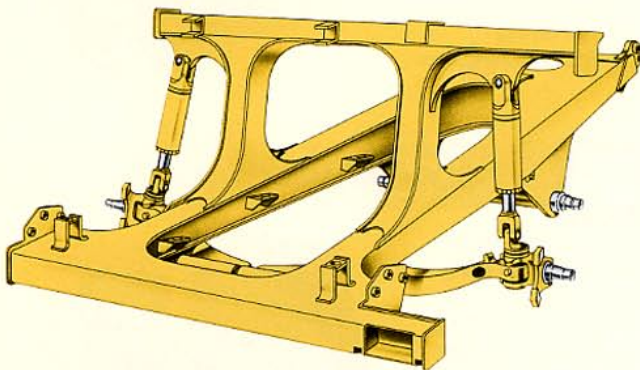

NEOCON struts outperform competitive strut designs by improving isolation, stability, and control. Improved isolation means reduced impact loading on structural members of the machine and greater operator comfort, resulting in longer equipment life and increased productivity. Improved stability means more consistent dynamic response of the machine to fluctuating load energy, resulting in predictable machine performance. Improved control means better machine maneuverability.

The Euclid frame and ACCU-TRAC suspension system are designed to work in unison to provide maximum structural integrity and operator comfort. The fabricated rectangular frame rail construction provides superior resistance to bending and torsional loads while eliminating unnecessary weight. The unique ACCU-TRAC independent trailing arm suspension absorbs haul road input, minimizing suspension-induced frame twisting while providing independent tire action. NEOCON ride struts are mounted with spherical bushings, eliminating extreme sidewall forces by insuring a purely axial input to the ride strut. The wide track stance of the ACCU-TRAC suspension system and the long wheel base assure a more stable, comfortable ride.



BODY

Heavy duty body is a flat floor, sloped tailshoot type. It is rubber cushioned and continuously exhaust-heated. High tensile strength 400 BHN abrasion-resistant alloy steel is used in thickness of:

Thicknesses	mm	in
Floor	20	3/4"
Front	12	1/2"
Sides	10	3/8"
Canopy	6	1/4"
Body Liners, Complete		
Floor & Corners	10	3/8"
Side, front, end protection	6	1/4"
Top rails	10	3/8"

High yield strength alloy steel is also used for canopy side members and floor stiffeners. The Euclid horizontal stiffener design minimizes stress concentrations. Load shocks are dissipated over the entire body length. Closely spaced stiffeners provide additional protection by minimizing distances between unsupported areas.

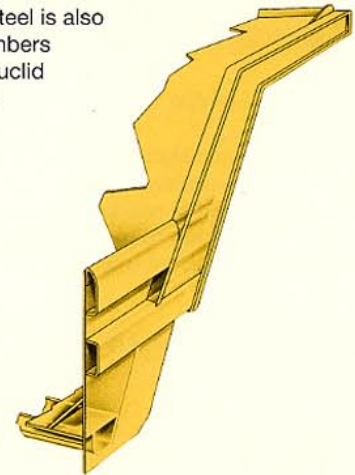

SERVICE CAPACITIES

	liters	gallons
Crankcase (includes filters)	54,9	14.5
Transmission	70,0	18.5
Cooling System	166,5	44.0
Fuel Tank	454,2	120.0
Hydraulics		
Hoist Tank	159,0	42.0
Steering Tank	90,8	24.0
Drive Axle	50,3	13.1
Windshield Washers	5,7	1.5



FRAME

Full fabricated box section main rails with section height tapered from rear to front being wider at the rear to support the loads and narrower at the front to allow for engine accessibility. One piece top and bottom flanges that eliminate cross member tie in joints and provide a large exposed center area for access to major components. Large radii at frame junctions minimize stress concentrations. Weld joints are oriented longitudinally to the principal flow of stress for greater durability and more strength. Frame utilizes 345 MPa 50,000 psi yield strength alloy steel that is robotically welded to ensure high quality welds.

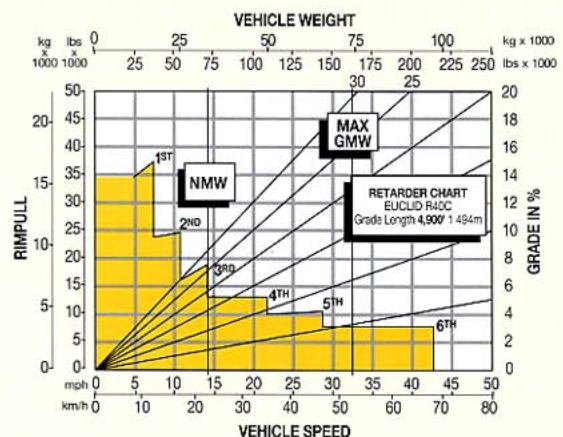
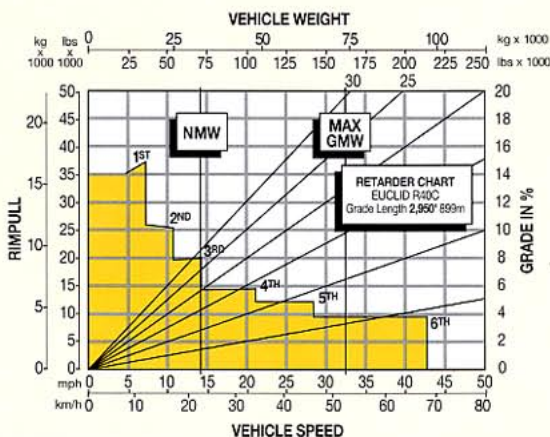
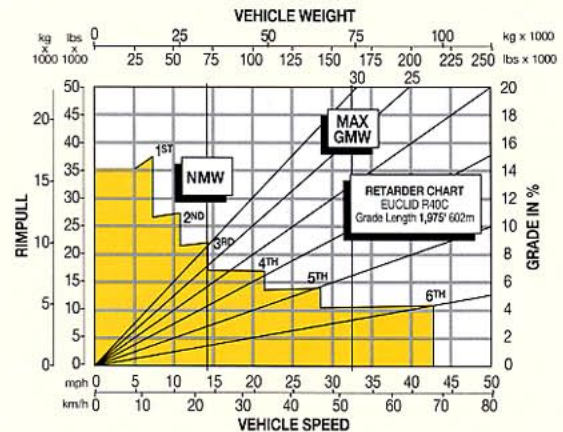
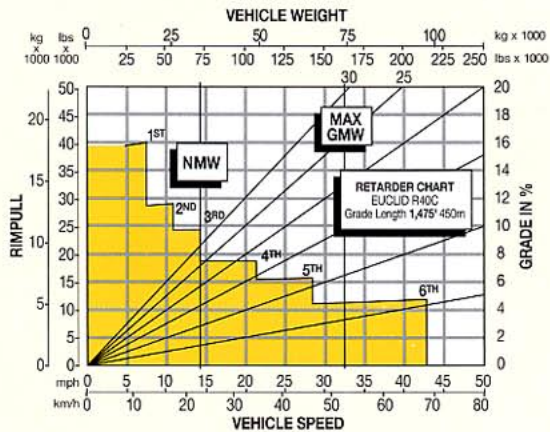
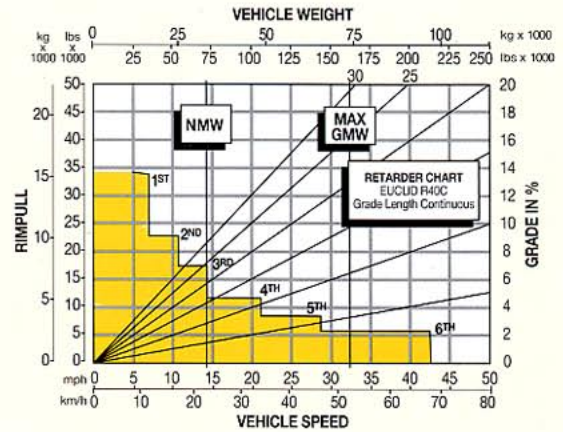
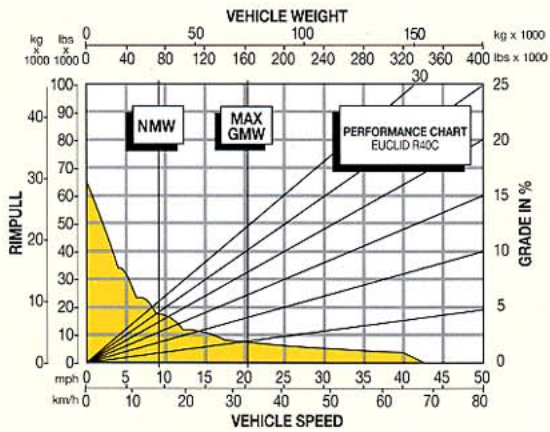

INSTRUCTIONS:

Diagonal lines represent total resistance (Grade % plus rolling resistance %). Charts based on 0% rolling resistance, standard tires and gearing unless otherwise stated.

1. Find the total resistance on diagonal lines on right-hand border of performance or retarder chart.
2. Follow the diagonal line downward and intersect the NMW or GMW weight line.
3. From intersection, read horizontally right or left to intersect the performance or retarder curve.
4. Read down for machine speed.

NOTE: Photos and illustrations throughout may show optional equipment.

NOTE: Maximum payload, weight and speed may vary with application and optional equipment.

Under our policy of continuous product improvement, we reserve the right to change specifications and design without prior notice. The illustrations do not necessarily show the standard version of the machine.

EUCLID-HITACHI Heavy Equipment, Inc. is a joint venture corporation between Volvo Construction Equipment Corporation and Hitachi Construction Machinery Co., Ltd.

EUCLID-HITACHI Heavy Equipment, Inc.

22221 St. Clair Ave.
Cleveland, OH 44117-2522
www.euclid-hitachi.com



FORM NO. 21 4 431 1557 EU
DATE 3/98
Printed in U.S.A.