



Euclid R170



MAXIMUM GMW
615,000 lbs.
(279 210 kg)

PAYLOAD RANGE
170.0 TO 190.0 TONS
(154.2 TO 172.4 TONNES)

ELECTRIC DRIVE
GE 776 WHEEL MOTOR

EXTENDED RANGE
ELECTRIC DYNAMIC RE-
TARDING

ALL HYDRAULIC BRAKING

TWO MAN CAB

NEOCON SUSPENSION

SEPARATE HYDRAULIC
RESERVOIRS FOR
STEERING AND HOIST

EUCLID



ENGINES

Make	Cummins	Detroit Diesel
Model	KTA50-C	16V-149TIB
Type	4 Cycle	2 Cycle
Aspiration	Turbocharged	Turbocharged
Rated Output		
(SAE)	1600 bhp (1193 kW @ 1900 rpm)	1600 bhp (1193 kW @ 1900 rpm)
Flywheel Output		
(SAE)	1519 bhp (1113 kW @ 1900 rpm)	1492 bhp (1113 kW @ 1900 rpm)
No. Cylinders	16	16
Bore & Stroke ...	6-1/4" x 6-1/4" (159mm x 159mm)	5-3/4" x 5-3/4" (146mm x 146mm)
Displacement ...	3067 in ³ (50.3 litres)	2384 in ³ (39.1 litres)
Max. Torque	4400 lb-ft (5966 N•m @ 1500 rpm)	4804 lb-ft (6514 N•m @ 1600 rpm)
Starting	Air	Air
*Optional	1800 bhp (1342 kW @ 1900 rpm)	1800 bhp (1342 kW @ 1900 rpm)



ELECTRIC DRIVE

Controls

General Electric Statex SSL System.

Alternator

General Electric Model GTA-22H. Direct mounted to engine.

Wheel Motors - Standard

General Electric Model 776KS complete with planetary assembly in each rear wheel.

Ratio 28.85:1

Max. Speed 34.4 mph (55.4 km/h)

Module Package

Radiator with fan, engine, alternator and blower mounted on sub frame within main frame.



TIRES

Standard - Front and Rear	Rim Width
Goodyear 36.00-51(50)E-4	26.0" (660mm)
Optional - Front and Rear	
Goodyear 36.00R51**RL-4H	26.0" (660mm)
Plus optional Goodyear tire types, treads, and ply ratings.	



LOAD CAPACITY

	yd ³	(m ³)
Struck (SAE)	89.5	(68.4)
Heap 3:1	115.1	(88.0)
Heap 2:1 (SAE)	126.9	(97.0)
Based on material density, VME will size an optional body. Consult VME Market Support.		



ELECTRICAL

Twenty-four volt lighting and accessories system. Seventy-five amp alternator with integral transistorized voltage regulator. Two 12 volt heavy duty batteries connected in series.



HYDRAULICS

Two (2) Euclid three-stage, double-acting cylinders, inverted and outboard mounted. Separate reservoir and independent gear pump. Direct operating control valve mounted on reservoir.

Body Raise Time 25 sec.

Body Float Down Time 20 sec.

Hoist Pump Output (@ 1900 rpm) 134 g/m (507 l/m)

System Relief Pressure 2,500 psi (17 238 kPa)



WEIGHTS

	lb	(kg)
Chassis with Hoists	188,070	(85 308)
Body	45,650	(20 707)
Net Machine Weight	233,720	(106 015)
Front Axle	115,294	(52 297)
Rear Axle	118,426	(53 718)
Payload	340,000	(154 224)
Maximum Payload with Optional Tires ...	381,280	(172 949)
36.00-51(50)E-4		
Max. Gross Machine Weight	576,150	(261 342)
Maximum Payload	342,430	(155 326)
36.00R51**RL-4H		
Max. Gross Machine Weight*	615,000	(278 964)
Maximum Payload	381,280	(172 949)
Loaded Weight Distribution		
Front - 33% Rear - 67%		
Machine weight based on 50% fuel		
* Maximum gross machine weight plus fuel and payload not to exceed		
(including options)	615,000	(278 964)

Options:

Body Liners, Complete:

3/4" (19mm) floor, 5/8" (16mm) corners,

3/8" (10mm) sides, front and top rails,

1/4" (6mm) canopy 21,900 (9 934)

Tires (set of 6):

36.00-51(58) E-4 2,796 (1 268)

36.00R51**RL-4H 1,356 (615)

*Max. GMW subject to G.E. approval for a given application.

Option/Add Wt.



STEERING

Closed center full time hydrostatic power steering system using two double acting cylinders, piston type pump and combined brake/steering system reservoir. Accumulator provides supplemental steering in accordance with SAE J53 and I.S.O. 5010.

Steering Angle 41°

Turning Diameter (SAE) 84 ft (25.6m)

Steering Pump Output (@ 2100 rpm) 33 g/m (126 l/m)

Operating System Pressure 2,500 psi (17 238 kPa)

STANDARD EQUIPMENT

General

Air cleaner guards	Hoist kickout
Air horns, dual	Mirrors, right and left
Body down indicator, mechanical	Moisture ejector, automatic
Body prop cable	Mud flaps
Extended range dynamic retarding (3 steps)	Operator arm guard
Fan guard	Radiator grille guard
Fully hydraulic brake system	Retard speed control
Ground level air start charge line	Reverse alarm
Guard rails around platform	Rock ejector bars
	Supplementary steering system, accumulator
	Tow hooks, front

Cab

Ash tray	Passenger seat and belt
Cab interior light	Rubber floor mat
Cigar lighter	Sun visor
Heater and defroster	Tilt steering wheel
Load and hold switch	Tinted glass, all windows
Load counter	Windshield washer
Operator seat, air ride	Windshield wiper, two speed
Operator seat belt	

Gauges and Indicators

Air cleaner restriction gauge	Parking/Load and hold brake indicator light
Air start pressure gauge	Rear brake malfunction indicator light*
Blower loss indicator light	Speedometer
Coolant temperature gauge	Steering filter restriction indicator light
Engine oil pressure gauge	Steering pressure gauge
Gauge lights	Steer system malfunction indicator light*
Ground fault indicator light	Tachometer
High beam indicator light	Voltmeter
Hourmeter	
Hydraulic filter restriction indicator light	

*includes audible alarm

Machine Lights

Back-up light	Headlights, four
Clearance lights, four	Rear axle light
Control cabinet lights, two	Turn signals and four-way flashers
Dual combination stop and taillights, two	
Dynamic retarding light	
Engine compartment lights	

OPTIONAL EQUIPMENT

Air conditioning	Foreign language decals and name plates
Air dryer	Fuel gauge
Alternate air starter	Halogen headlights
Automatic lubrication system	Hubodometer (Metric or Imperial)
Battery isolation switch	Kim Hotstart
Body liner plates, std. and heavy duty	Manually actuated centralized lube
Buddy dump	Metric speedometer
Buddy steer	Multi-function engine & hydraulics system alarms (low oil pressure, low oil level, high coolant temperature, low coolant level, low hydraulic fluid level)
Centralized service panel fluids	On board load box
Cold starting aid	Propulsion interlock, body up
Engine access ladders	Radiator shutters
Engine coolant and oil heater (220 VAC)	Retard speed control
Extended range dynamic retarding (7 steps)	Reverse pedal configuration
Fast fueling system (Wiggins) on tank	Start interlock (maintenance)
Field repairable core radiator	Tachograph, 24 hr. recording
Fire protection systems (manually actuated with engine shutdown)	Top extensions

Standard and optional equipment may vary from country to country. Special options provided on request. Consult VME Market Support.

Note: Dimensions shown are for empty machine with 36.00-51 tires.

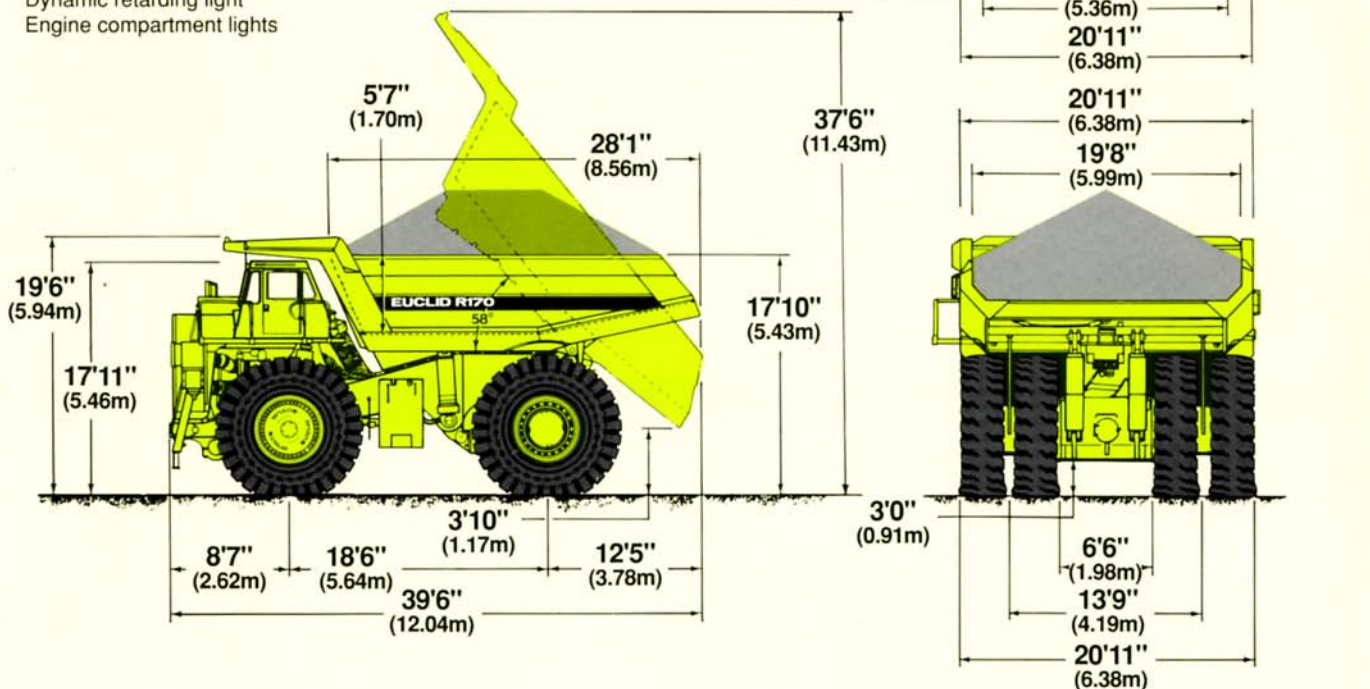



SUSPENSION

Front Suspension

Independent trailing arm for each front wheel. Neocon struts containing energy-absorbing gas and compressible neocon-x fluid are mounted between trailing arm and frame. Variable damping and rebound feature included.

Rear Suspension

"A" frame structure, integral with axle housing, links drive axle to frame at forward center point with pin and spherical bushing. Track rod provides lateral stability between frame and drive axle. Rear mounted neocon struts containing energy-absorbing gas and compressible neocon-x fluid suspend drive axle from frame. Maximum wheel oscillation 8°

The Euclid frame and suspension are designed to work in unison to provide maximum structural integrity and operator comfort. The tapered box beam frame rail construction provides superior

resistance to bending and torsional loads while eliminating unnecessary weight.

Euclid achieves long frame fatigue life through proven design and manufacturing practices.

Smooth transitions minimize stress concentrations and steel castings effectively distribute input loads. Frame life is further enhanced by utilizing fatigue resistant weld joints and locating welds in low stress areas.

The unique trailing arm front suspension absorbs haul road input, minimizing suspension-induced frame twisting while providing independent tire action. Suspension struts are mounted with spherical bushings, eliminating extreme sidewall forces by insuring a purely axial input to the strut. The wide track stance of the trailing arm design and long wheelbase assure a more stable, comfortable ride.

The suspension struts employ gas and neocon-x fluid as the energy-absorbing media. This suspension continues to absorb energy when extreme dynamic loads are generated which significantly contributes to improved isolation of the operator and machine components.

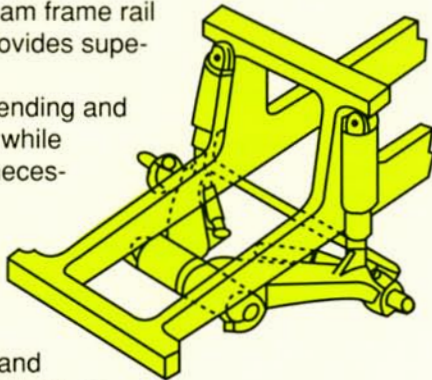

COMMAND CAB II

Structurally Sound.

Command Cab II, doublewall construction of 11 gauge inner and outer steel panels, lends itself to a more structurally sound cab.

Foam rubber lining material along with

foam rubber backed carpeting and multiple layered floor mat act to absorb sound and control interior temperature. A three-point rubber iso-mount arrangement to the deck surface minimizes vibration to the operator's compartment.



Ease of Operation and Systems Monitoring.

A wrap-around style dashboard positions the controls within easy reach and visual contact. A full compliment of easy-to-read, color banded gauges with international symbols and centrally positioned tachometer, speedometer and bank of warning lights provide the operator information required to safely pilot the machine.

Excellent Serviceability.

A removable front closure allows easy access to electrical components, brake master cylinder, retarder valve and washer bottle. All electrical junction points are located in the front compartment. The filter is located to the side of the cab and servicing requires the removal of only two bolts. The upper dash utilizes four (4) removable panels to house gauges and customer options. Each panel is individually removed from inside the cab and only those requiring service need to be removed.

Designed for Operator Comfort.

Command Cab II standard equipment includes the Isringhausen six-way adjustable air seat, tilt steering wheel, filtered ventilation, insulated interior under the cab heading, and a fully upholstered trainers seat that folds down to reveal a tray for lunch boxes and other gear.



AIR

Compressor

Detroit Diesel	12.0 cfm	(5.7 l/s)
Cummins	30.0 cfm	(14.2 l/s)

Service Air

Pressure	125 psi	(860 kPa)
----------------	---------	-----------

Start System

Pressure	125 psi	(860 kPa)
Reservoir Capacity	20 ft ³	(566 litres)



SERVICE CAPACITIES

	gallons	(litres)
Crankcase (incl. filters)		
Cummins	46.0	(193.0)
Detroit Diesel	41.0	(151 .4)
Cooling System	115.0	(435.3)
Fuel Tank	510.0	(1 930.4)
Hydraulics		
Hoist Tank	133.0	(503.0)
Steering Tank	40.0	(151 .0)
GE776 wheel motors	10.0	(37.8)



BODY

Flat floor, sloped tailchute, continuously exhaust heated. High yield strength 100,000 psi (690 N/mm²) alloy steel used in thickness of:

Floor	3/4"	(19mm)
Front	3/8"	(10mm)
Sides	3/8"	(10mm)
Canopy	1/4"	(6mm)

High yield strength 100,000 psi (689 N/mm²) alloy steel also used for canopy side members and floor stiffeners. Body is rubber cushioned on frame.

The horizontal stiffener design of the Euclid body minimizes stress concentrations in any one area. Load shocks are dissipated over the entire body length. The closely spaced stiffeners provide additional protection by minimizing distances between unsupported areas.

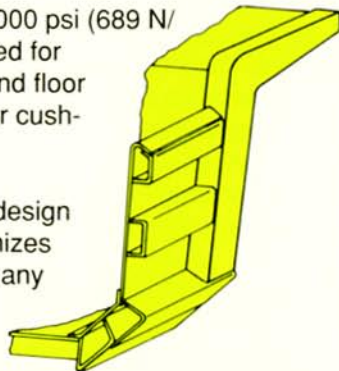

FRAME

Box section main frame rails bridged by three crossmembers, front bumper and front suspension tube. Rails are constant taper, constructed of 100,000 psi (689 N/mm²) yield strength steel. Two rear crossmembers have integral suspension and drive axle mountings. Crossmember to frame rail junctions use large radii to minimize stress concentrations.



ALL-HYDRAULIC BRAKING

Service

All-hydraulic actuated. Three calipers per front disc, one caliper per rear disc. Calipers are internally ported, each containing three pairs of opposing pistons.

Front Axle

BFGoodrich Model J6 wheel speed brakes

Disc Diameter Each (2 discs/axle) 42 in (106.7cm)

Lining Area Per Axle 960 in² (6 194 cm²)

Brake Pressure (Max.) 2500 psi (17 238 kPa)

Rear Axle - Standard GE 776 wheel motors

BFGoodrich series "F" armature speed brakes

Disc Diameter Each (4 discs/axle) 20.1 in (51.1 cm)

Lining Area Per Axle 376 in² (2 426 cm²)

Brake Pressure (Max.) 1300 psi (8 964 kPa)

Secondary

Three independent hydraulic circuits within the service brake system provide secondary stopping capability. System is manually or automatically applied to stop vehicle within prescribed braking distance.

Parking

Spring-on, hydraulic-off brake heads provide parking capabilities. Brake systems comply with SAE 1473 and I.S.O. 3450.

Retarder

Retardation on down grades achieved through D.C. wheel motors in conjunction with General Electric resistor grid package located on cab deck. Cooling for this grid package is achieved with forced air flow provided by dual blowers driven by a single electric motor. 3-step extended range retardation package is standard.

Maximum Dynamic Retarding with continuous rated blown grids 2700 bhp (2013 kW)

The Euclid R170 is equipped with an all-hydraulic actuated braking system providing increased braking force and quick system response. A primary accumulator stores oil under sufficient pressure so that 100% braking pressure is always available.

The main valves in the all-hydraulic brake system are conveniently located at shoulder height on the forward left hand frame rail. The placement of this valve package enhances serviceability as all pressure checks and system troubleshooting can be made at this central location. Steel tubing is used to eliminate line swell and ruptures commonly associated with hose assemblies. Sheet metal guards protect the valve package and tubing.

The system is pressure proportioned, front to rear, for improved slippery road control. Three independent hydraulic circuits within the service braking system and dual secondary accumulators provide secondary stopping capability. The Euclid R170 has been designed with a simplified, easier to maintain brake system that provides superior stopping performance.

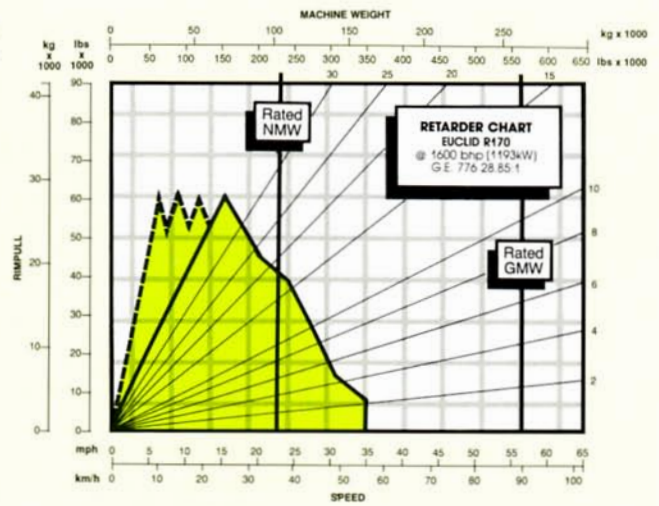
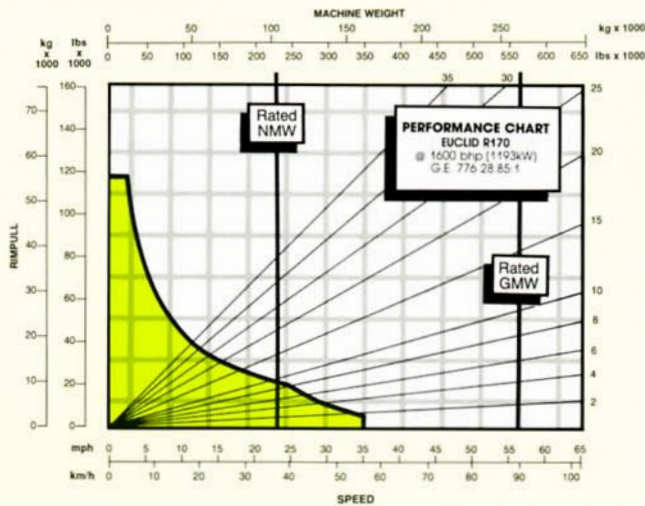

INSTRUCTIONS:

Diagonal lines represent total resistance (Grade % plus rolling resistance %). Charts based on 0% rolling resistance, standard tires and gearing unless otherwise stated.

1. Find the total resistance on diagonal lines on right-hand border of performance or retarder chart.
2. Follow the diagonal line downward and intersect the NMW or GMW weight line.
3. From intersection, read horizontally right or left to intersect the performance or retarder curve.
4. Read down for machine speed.

Under our policy of continuous product improvement, we reserve the right to change specifications and design without prior notice. This publication does not necessarily reflect the standard version of the machine.

VME Americas Inc.

23001 Euclid Avenue
P.O. Box 178017
Cleveland, Ohio 44117-8017

FORM NO. RH536 EURO
DATE 12/90
Printed in U.S.A.