



Euclid R130



MAXIMUM GMW
480,000 lb (217 700 kg)

PAYLOAD RANGE
130 TO 152.5 TONS
(118 TO 138.4 TONNES)

COMMAND CAB II

ALL-HYDRAULIC BRAKING

**ATEC AUTOMATIC SHIFT
CONTROL**

NEOCON SUSPENSION

**SEPARATE HYDRAULIC
RESERVOIRS**

**NON-WEARING
TRANSMISSION RETARDER**

**COUPLED PLANETARY
FINAL DRIVE SYSTEM**

EUCLID



ENGINE

Make	Detroit Diesel	Cummins
Model	12V-149TIB	KTTA38-C
Type	2 Cycle	4 Cycle
Aspiration	Turbocharged/ Intercooled	Turbocharged
Rated Output (SAE)	1350 bhp @ 1900 rpm (1007 kW)	1350 bhp @ 2100 rpm (1007 kW)
Flywheel Output (SAE) ...	1200 bhp @ 1900 rpm (895 kW)	1200 bhp @ 2100 rpm (895 kW)
No. Cylinders	12	12
Bore & Stroke	5-3/4" x 5-3/4" (146 mm x 146 mm)	6-1/4" x 6-1/4" (159 mm x 159 mm)
Displacement	1788 in ³ (29,3 litres)	2300 in ³ (37,7 litres)
Max. Torque	3909 lb-ft @ 1400 rpm (3300 N·m)	3882 lb-ft @ 1500 rpm (5264 N·m)
Starting	Air	Air



TRANSMISSION

Allison CLBT-9681. Planetary type, full automatic shifting. Integral torque converter with automatic lock-up in all ranges and hydraulic retarder. Remote mounted, 6 forward speeds, 1 reverse. Allison Transmission Electronic Control (ATEC) shift system.

Range	Gear Ratio	STANDARD 1.56:1 Diff.		OPTIONAL 1.56:1 Diff.		OPTIONAL 1.56:1 Diff.	
		17.06:1 Plan.	21.44:1 Plan.	17.06:1 Plan.	21.44:1 Plan.	17.06:1 Plan.	21.44:1 Plan.
		mph (km/h)	mph (km/h)	mph (km/h)	mph (km/h)	mph (km/h)	mph (km/h)
1	4.22	6.5 (10,5)	5.2 (8,4)	7.8 (12,6)			
2	3.05	9.1 (14,6)	7.2 (11,6)	10.9 (17,5)			
3	2.32	11.9 (19,2)	9.5 (15,3)	14.3 (23,0)			
4	1.67	16.6 (26,7)	13.2 (21,2)	19.9 (32,0)			
5	1.00	27.7 (44,6)	22.1 (35,5)	33.2 (53,4)			
6	0.73	38.5 (61,9)	30.6 (49,3)	46.1 (74,2)			
R	5.75	4.8 (7,8)	3.8 (6,2)	5.8 (9,3)			



TIRES

Standard - Front and Rear	Rim Width
Goodyear 33.00R51(50)E-4	24.0" (610 mm)
Optional - Front and Rear	
Goodyear 33.00R51**RL-4H	24.0" (610 mm)

Plus optional Goodyear tire types, treads and ply ratings.



LOAD CAPACITY

Struck (SAE)	65.8	yd ³	(m ³)
Heap 3:1	85.1		(50,3)
Heap 2:1 (SAE)	94.0		(65,1)
Payload		Tons	(Tonnes)
From	130.0		(71,9)
Maximum	152.5		(117,9)
			(138,4)

Based on material density, VME will size an optional body.
Consult VME's Market Support Department.



ELECTRICAL

Twenty-four volt lighting and accessories system. Seventy-five amp alternator with integral transistorized voltage regulator. Two 12 volt heavy duty batteries connected in series.



DRIVE AXLE

Full floating axle shafts, reduction provided by Euclid Model 2655 differential and dual path planetary with balanced life gearing in each wheel.

Ratios	Standard	Optional	Optional
Differential	1.56:1	1.56:1	1.56:1
Planetary	17.06:1	21.44:1	14.23:1
Total Reduction	26.61:1	33.45:1	22.20:1

Maximum Speeds

with 33.00-51 tires	38.5 mph	30.6 mph	46.1 mph
	(61,9 km/h)	(49,3 km/h)	(74,2 km/h)

The R130 utilizes a coupled planetary system with two sets of gears in each wheel. Each set of gears helps drive its respective wheel, effectively sharing torque loads. This concept keeps individual gear loading to a minimum, thereby promoting longer component lives.



HOIST

Two (2) Euclid three-stage, double-acting cylinders, inverted and outboard mounted. Separate reservoir and independent gear pump. Control valve mounted on reservoir.

Body Raise Time	20 sec.
Hoist Pump Output (@ 2100 rpm)	161 g/m (609 l/m)
System Relief Pressure	2500 psi (17 237 kPa)



WEIGHTS

	lb	(kg)
Chassis with Hoists	140,700	(63 822)
Body	34,250	(15 540)
Net Machine Weight	174,950	(79 357)
Front Axle	82,450	(37 399)
Rear Axle	92,500	(41 958)
Maximum GMW with Selected Tires		
33.00-51(50)E-4		
Max. Gross Machine Weight	480,000	(217 700)
Net Machine Weight	174,950	(79 357)
33.00R51**RL-4H		
Max. Gross Machine Weight	480,000	(217 700)
Net Machine Weight	176,750	(80 174)
Maximum Payload	305,050	(138 371)

Loaded Weight Distribution

Front - 33% Rear - 67%

Machine weight based on 50% fuel

Maximum gross machine weight not to exceed 480,000 lbs
(217 700 kg) including options, fuel and payload.

Options:

Body Liners, Complete:

3/4" (19 mm) floor		
3/8" (10 mm) side		
3/8" (10 mm) front		
1/4" (6 mm) canopy		
1/4" (6 mm) corners		
3/8" (10 mm) top rail		
1/2" (13 mm) end protectors	17,700	(8 029)

Tires (set of 6):

33.00R51**RL-4H (Add'l. weight)	1,800	(820)
---------------------------------------	-------	-------



SUSPENSION

Front and Rear Suspension

Independent trailing arm for each front wheel. Neocon struts containing energy-absorbing gas and compressible fluid are mounted between trailing arm and frame. Rebound feature included. "A" frame structure, integral with axle housing, links drive axle to frame at forward center point with pin and spherical bushing. Track rod provides lateral stability between frame and drive axle. Rear mounted Neocon struts suspend drive axle from frame. Neocon struts provide variable damping and rebound feature.

The Euclid frame and suspension are designed to work in unison to provide maximum structural integrity and operator comfort. The tapered box beam frame rail construction provides superior resistance to bending and torsional loads while eliminating unnecessary weight. VME achieves long frame fatigue life through proven design and manufacturing practices.

Smooth frame transitions minimize stress concentrations and steel castings effectively distribute input loads. Frame life is further enhanced by utilizing fatigue resistant weld joints and locating welds in low stress areas.

The unique trailing arm front suspension absorbs haul road input, minimizing suspension-induced frame twisting while providing independent tire action. Ride struts are mounted with spherical bushings, eliminating extreme sidewall forces by insuring a purely axial input to the ride strut. The wide track stance of the trailing arm design and long wheel base assure a more stable, comfortable ride.

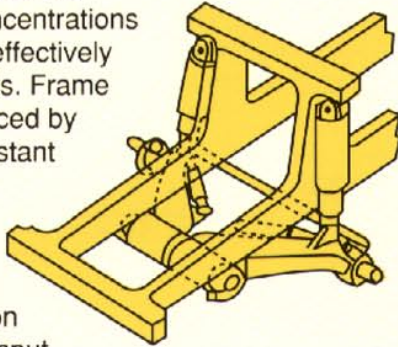

The suspension struts employ gas and Neocon-x fluid as the energy-absorbing media. This suspension continues to absorb energy when extreme dynamic loads are generated which significantly contributes to improved isolation of the operator and machine components.



FRAME

Box section main frame rails bridged by three crossmembers, front bumper and front suspension tube. Rails are constant taper, constructed of 100,000 psi (689 N/mm²) yield strength steel. Two rear crossmembers have integral suspension and drive axle mountings. Crossmember to frame rail junctions use large radii to minimize stress concentrations.



COMMAND CAB II

Structurally Sound

Command Cab II, double wall construction of 11 gauge inner and outer steel panels lends itself to a more structurally sound cab. Foam rubber lining material along with foam rubber backed carpeting and multiple layered floor mat act to absorb sound and control interior temperature. A three-point rubber iso-mount arrangement to the deck surface minimizes vibration to the operator's compartment.

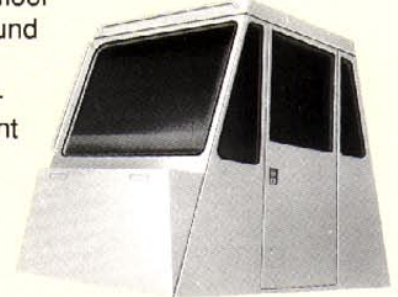

Ease of Operation and Systems Monitoring

A wrap-around style dashboard positions the controls within easy reach and visual contact. A full compliment of easy-to-read, color banded gauges with international symbols and centrally positioned tachometer, speedometer and bank of warning lights provide the operator information required to safely pilot the machine.

Excellent Serviceability

A removable front closure allows easy access to electrical components, service brake valve, retarder valve and washer bottle. All electrical junction points are located in the front compartment. The filter is located to the side of the cab and servicing requires the removal of only two bolts. The upper dash utilizes four (4) removable panels to house gauges and customer options with each individually accessible.

Designed for Operator Comfort

Command Cab II standard equipment includes a six-way adjustable air seat, tilt steering wheel, filtered ventilation and a fully upholstered trainers seat that folds down to reveal a tray for lunch boxes and other gear.



STEERING

Closed center full time hydrostatic power steering system using two double-acting cylinders, piston type pump and combined brake/steering system reservoir. Accumulator provides supplementary steering in accordance with SAE J53 and ISO 5010.

Steering Angle	42°
Turning Diameter (SAE)	80'6" (24,5 m)
Steering Pump Output (@ 2100 rpm)	34 g/m (129 l/m)
Operating System Pressure	2500 psi (17 237 kPa)



ALL-HYDRAULIC BRAKING

Service

All-hydraulic actuated. Two calipers per disc, front and rear. Calipers are internally ported, each containing three pairs of opposing pistons.

Front Axle and Rear Axle

BFGoodrich Model J6 wheel speed brakes

Disc Diameter Each	42 in (106,7 cm)
Lining Area Per Axle	640 in ² (4 129 cm ²)
Brake Pressure (Max.)	2500 psi (17 237 kPa)

Secondary

Three independent hydraulic circuits within the service brake system provide secondary stopping capability. System is manually or automatically applied to stop machine within prescribed braking distance.

Parking

Spring-on, hydraulic-off disc brakes mounted behind transmission on driveline provide parking capabilities.

Brake systems comply with SAE J1473 and ISO 3450.

Retarder

Foot operated valve allows operator to control oil flow into paddlewheel type retarder integral with transmission housing. Provides constant speed control on downhill hauls.

Maximum retarding output (includes engine friction bhp) @ 2200 rpm	2561 bhp (1 910 kW)
---	---------------------

The Euclid R130 is equipped with an all-hydraulic actuated braking system providing increased braking force and quick system response. A primary accumulator stores oil under sufficient pressure so that 100% braking pressure is always available.

The main valves are conveniently located at shoulder height on the forward left hand frame rail. The modular valve package enhances serviceability as all pressure checks and system troubleshooting can be made at this central location. Steel tubing is used to eliminate line swell and ruptures commonly associated with hose assemblies. Sheet metal guards protect the valve package and tubing. The system is pressure proportioned, front to rear, for improved slippery road control.



BODY

Flat floor, sloped tailchute, continuously exhaust heated. High yield strength 100,000 psi (689 N/mm²) alloy steel used in thickness of:

Floor	3/4" (19 mm)
Front	3/8" (10 mm)
Sides	3/8" (10 mm)
Canopy	3/16" (5 mm)

High yield strength 100,000 psi (689 N/mm²) alloy steel also used for canopy side members and floor stiffeners. Body is rubber cushioned on frame.

The horizontal stiffener design of the Euclid body minimizes stress concentrations in any one area. Load shocks are dissipated over the entire body length. The closely spaced stiffeners provide additional protection by minimizing distances between unsupported areas.

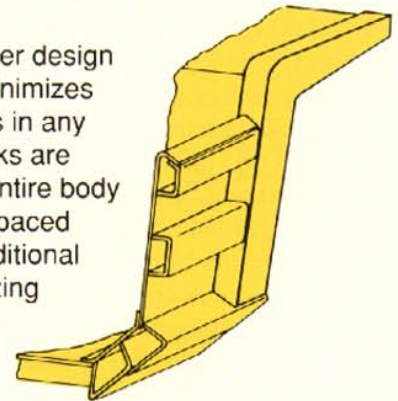

SERVICE CAPACITIES

	gallons	(litres)
Crankcase (incl. filters)		
Cummins	40.0	(151,4)
Transmission	30.0	(113,6)
Cooling System	95.0	(359,6)
Fuel Tank	510.0	(1 930,4)
Hydraulics		
Hoist Tank	133.2	(504,2)
Steering Tank	39.7	(150,3)
Drive Axle		
Differential	60.0	(227,1)
Planetaries	40.0	(151,4)



AIR

Compressor	12.0 cfm	(5,7 l/s)
Service Air Pressure	125 psi	(860 kPa)
Start System Pressure	125 psi	(860 kPa)
Reservoir Capacity	16 ft ³	(453 litres)

STANDARD EQUIPMENT

General

Air cleaner guards	Hoist kickout
Air horns, dual	Mirrors, right & left
Allison Transmission	Moisture ejector
Electronic Control (ATEC)	Mud flaps
Body down indicator, mechanical	Operator arm guard
Body prop cable	Park brake interlock
Fan guard	Radiator grille guard
Fully hydraulic brake system	Reverse alarm
Ground level air start charge line	Rock ejector bars
Guard rails around platform	Supplementary steering system, accumulator
Hoist interlock	Tow hooks, front

Cab

Ash tray	Passenger seat & belt
Cab interior light	Rubber floor mat
Cigar lighter	Sun visor
Engine shutdown switch	Tilt steering wheel
Heater & defroster	Tinted glass, all windows
Load & hold switch	Windshield washer
Operator seat, air ride	Windshield wiper
Operator seat belt	

Gauges and Indicators

Air cleaner restriction gauge	Parking/Load & hold brake indicator light
Air start pressure gauge	Rear brake malfunction indicator light
Clutch pressure gauge	Speedometer
Converter lock-up indicator light	Steer system malfunction indicator light
Converter oil temperature gauge	Steering filter restriction indicator light
Coolant temperature gauge	Steering pressure gauge
Engine oil pressure gauge	Tachometer
Gauge lights rheostat	Transmission oil level sight gauge
High beam indicator light	Voltmeter
Hourmeter	
Hydraulic filter restriction indicator light	

Machine Lights

Back-up light
Clearance lights
Dual combination stop & taillights
Engine compartment lights
Headlights, four
Turn signals & four-way flasher

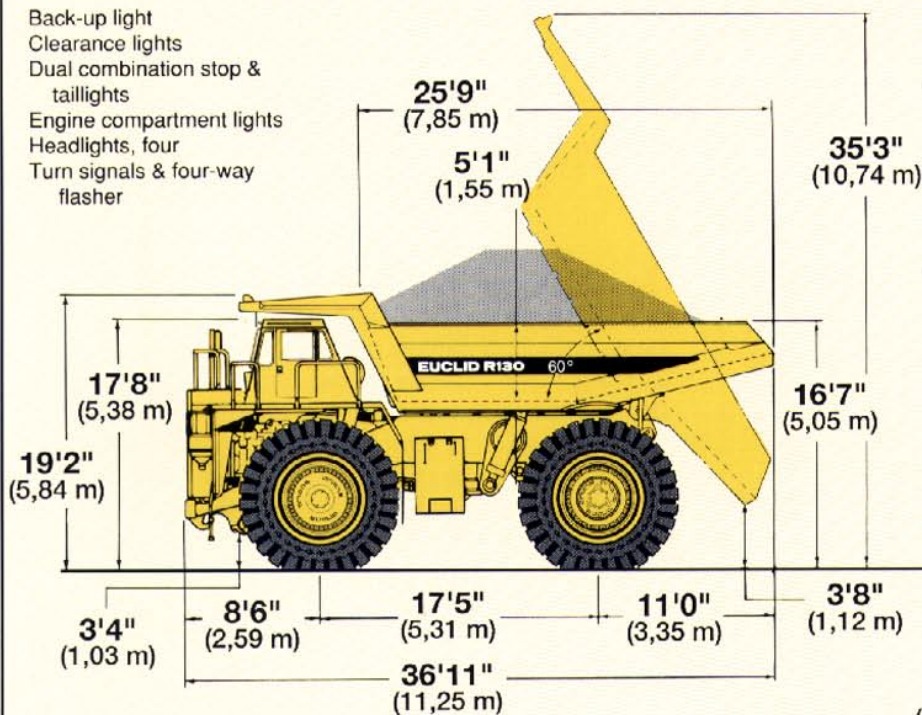

OPTIONAL EQUIPMENT

Air conditioner	Fast coupling service center (Wiggins)
Air dryer	Fast fueling system (Wiggins)
Alarm system, four function (low oil pressure, high coolant temperature, low coolant level, high conv. temperature)	Field repairable core radiator
Body capacity, 120 short ton (109 metric tonne)	Fire protection systems
Body liner (400 BHN) plates	Fuel gauge, cab or tank mounted
Buddy dump	Fuel tank, 600 gal. (2271 l)
Centralized lube	Hubodometer
Cold starting aid	Kim Hotstart
Electric start	Lube system, automatic
	Planetary ratio, 14.23:1
	Planetary ratio, 21.44:1
	Radio

Standard and optional equipment may vary from country to country. Special options provided on request. Consult VME Market Support Department.

Note: Illustration may include optional equipment.
Note: Dimensions shown are for empty machine with 33.00-51 tires.

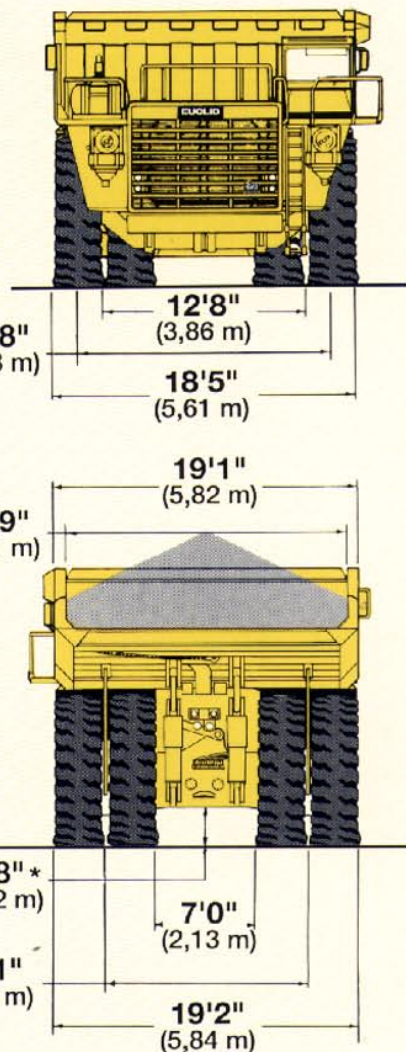

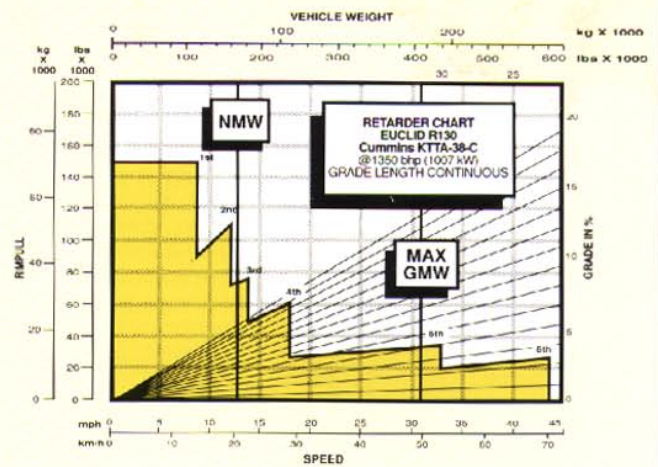
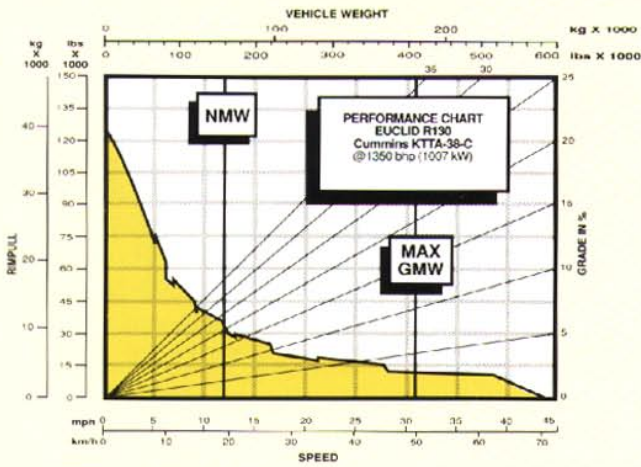

INSTRUCTIONS:

Diagonal lines represent total resistance (Grade % plus rolling resistance %). Charts based on 0% rolling resistance, standard tires and gearing unless otherwise stated.

1. Find the total resistance on diagonal lines on right-hand border of performance or retarder chart.
2. Follow the diagonal line downward and intersect the NMW or GMW weight line.
3. From intersection, read horizontally right or left to intersect the performance or retarder curve.
4. Read down for machine speed.

Under our policy of continuous product improvement, we reserve the right to change specifications and design without prior notice. This publication does not necessarily reflect the standard version of the machine.

VME Industries North America

A Business Unit of VME Americas Inc.

P.O. Box 178017
Cleveland, Ohio 44117-8017

FORM NO. RH 599
DATE 8/91
Printed in U.S.A.