

# Kockum 565





# An economical dump truck that carries 20 tonnes more than its tare

## Tare weight completely reappraised in 30 years

About 20—30 years ago, the price of a haulage vehicle was often evaluated in terms of the cost per tonne of tare weight. This meant that a poorly designed truck made of low-quality materials could compensate for this by means of large dimensions — and it would be considered better value for money than a truck with thoroughgoing design, made of high-quality steel. The idea was simply that a heavier truck was preferred to a lighter one. The general principle was that "The more castings and the larger the dimensions, the higher the quality". No one was particularly interested in the fact that the heavier truck would haul up to several tons of superfluous load for each metre it was driven, during its entire service life.

Development since then has been rapid indeed. Increased costs, above all for fuel, and more severe competition have forced vehicle owners to select their trucks on the basis of quite different criteria. A vehicle's efficiency is now measured in terms of the total cost per tonne of load hauled. This means that the tare weight of a truck is extremely important — simply because the

cost of transporting 1 tonne of tare weight in terms of general wear, fuel consumption, tyre wear, etc. is almost twice as great as the cost of hauling a tonne of load! The explanation is of course that dump trucks almost never carry return loads, but are driven empty for roughly one-half of their service lives.

## The load factor indicates efficiency

The various trucks on the market today have different load capacities and different tare weights. A comparison can thus appear difficult. A simple method which takes account of both capacity and weight involves comparing the load factor for each vehicle, i.e. the quantity of load the truck can carry for each tonne of tare weight. The Kockum 565 has a tare weight of 38.7 tonnes and a permissible maximum load capacity of 65 short tons, or about 59 tonnes. The load factor for the K565 is thus  $59.0:38.7 = 1.52$ . Another typical truck now on the market has a load capacity of 55 short tons, or about 50 tonnes, and a tare weight of 42.3 tonnes. The load factor for this vehicle is thus  $50.0:42.3 = 1.18$ .

— The load factor is a direct measure of

the load-carrying efficiency of the truck. In the example above, the difference is  $1.52 - 1.18 = 0.34$ , which means that the K565 is 28% more efficient than the other vehicle.

It may be difficult to compute the actual cost of hauling unnecessary tare tonnage. But the quantity of tonnage hauled during the service life of the truck speaks for itself. For example, if two trucks with the same load capacity and a 3-tonne difference in tare weight work the same 30 cycles per day for 200 days each year, the extra weight hauled by the heavier one will amount to 90,000 tonnes over 5 years.





# hat loads weight

## Low tare weight combined with high quality

As early as the end of the 1950's, when Kockum Landsverk began producing trucks, haulage efficiency was one of the most important design goals. Of the six rigid trucks in our product range, not one has a load factor of less than 1.35.

Most of the trucks delivered by Kockum Landsverk during the 1960's are still in operation. We maintain contact with many Kockum machines that have an honest 25—30,000 hours on their clocks and are still economical to run. The record-holding vehicle is now approaching the 50,000 hour mark.

What is the secret of designing a dump truck that combines low tare weight with high quality? This is a complex question, but the answer can be summarized as follows: A design that is highly functional down to the last detail, where top-quality materials and optimal dimensions are combined at precisely the right points. Another advantage comes from being a specialized producer — with designers, service personnel and marketing engineers who do not dissipate their energies on many different types of contracting vehicles, but concentrate year-in and year-out on a single task — providing a transport vehicle that is as load-efficient and as economical as possible.



um 565



# As compact and manoeuvra as a 50-tonner!

All the trucks in the Kockum range of rigid dump trucks have certain characteristics in common — including low tare weight and compact design. In the Kockum 565 even the latter principle has been applied so as to exceed our expectations. To back up this claim, we've compared some of the most important statistics for the K565 with the average values for the five most popular 50-tonners on the market. This "average" truck is designated the X50 in the table below.

	K565	"X50"	Remarks
Load capacity, tonnes	59.0	45.4	Difference = 13.6 tonnes
Tare weight, tonnes	38.7	36.5	The K565 weighs 2.2 tonnes more but carries a 30% greater effective load.
Load factor	1.52	1.25	Difference = 0.27, or a 21% greater load efficiency for the K565.
Loading height, m (without load)	3.64	3.58	The loading height of the K565 is only 6 cm greater. This allows for rapid loading and the use of the same size loader.
Turning radius, m	8.92	9.32	The variations between the 50-tonners are large — from 10.75 to 8.00 m. The K565 is obviously easier to manoeuvre than the average truck in this capacity class.
Body volume, m <sup>3</sup> SAE 2:1	40.4	31.5	Both the K565 and the X50 have bodies designed for material with a specific weight of approx. 1.45. The difference in capacity corresponds to the difference in body volume — 8.9 m <sup>3</sup> at SAE 2:1.
Length, m	9.40	9.26	The K565 has definitely larger track width and thus a greater vehicle width — 0.52 respectively 0.37. The demand for high stability was decisive here. Another factor contributing to the excellent stability is the greater body width, which lowers the centre of gravity of the load and thus of the truck.
Height, m	4.05	4.25	
Width, m	4.55	4.18	
Track width, front, m	3.84	3.32	

## Simple, straightforward frame design

The frame is an extremely light structure that includes all-welded box sections of selected high-strength steel. The design is simple and straightforward without any unnecessary transition pieces or transverse joints. All mountings have been rationalized to reduce weights and simplify design. Loads are distributed evenly over the entire frame, so that there are no direct concentrations of stress. The simplified design also allows for automatic welding, which ensures welds of high, uniform quality.

## Advanced rear axle suspension

The rear axle suspension is unique, consisting of a linkage system that provides a number of benefits. The longitudinal and transversal dynamic forces from the load are transmitted over the shortest path from the body pivot to the ground. Suspension motion does not generate any unnecessary increase in horizontal forces on the rear axle, as is the case with a conventional A-frame design.





## Rock body as standard

The basis of Kockum Landsverk's new body design is the high quality of the steel, which allows for application of simpler, lighter design principles. The material in the bottom and side plates meets maximum demands for wearability (HB 360—400) and strength (110 kp/mm<sup>2</sup>). This enables us to build a body with longitudinal reinforcements without using conventional transverse ribs. Concentrations of stress are eliminated, so that there is no risk of cracks. The geometry of the body has also been carefully analysed. The result is a compact but roomy unit with low loading height.

## Superior working environment

The K565 is designed for convenient cab entry by means of a sloping, retractable ladder. Visibility from the cab is excellent, and is especially evident in restricted spaces. The view of the road is excellent for a truck in this capacity class. The roomy cab is light and airy, with large, tinted windows and it has been designed in detail with respect to the driver's various tasks.

The ergonomically designed seat is adjustable for individual weight and body height, and is of course fitted with hydraulic suspension. A safety belt is standard equipment. Another vital safety feature is the soft, shock-absorbent material that covers the walls of the cab as well as all edges and protrusions.

Controls and instruments are positioned for maximum convenience and efficiency, with the most important ones directly in front of the driver. Less frequently used instruments are positioned in the ceiling of the cab, which can be fitted with a radio. All instruments are clearly marked with easily understood ISO symbols.

## True road "feel" and stable steering

The Kockum 565 gives the driver a real "feel" for the road. The truck is easy to

drive and easy to manoeuvre, and it runs smoothly even on rough surfaces, partly because it is fitted with oil-pneumatic suspension all round. Speed on the flat is 65 km/h.

The 674 HP engine has been selected with reference to the total vehicle weight as well as maximum fuel economy. Power is transmitted through an Allison CLBT 6061 powershift gearbox, a torque converter and a lock-up.

The double brake system includes disc brakes on the front wheels, and consists of a hydraulic retarder and a dual-circuit brake system, for safety and high performance.

The steering system is servo-assisted and incorporates mechanical feed-back. This design contributes to the excellent road "feel" as well as to improved safety.





# Kockum 565 — technical data

## Payload capacity

Payload	65 tons (59.000 kg)	
Payload volume, struck (SAE)	29,7 m <sup>3</sup>	
Payload volume, heaped 2:1 (SAE)	40,4 m <sup>3</sup>	

## Weight distribution

	kg	lbs
<i>Empty</i>		
Front axle	19.700	43.450
Rear axle	19.000	41.900
Total	38.700	85.350
<i>Loaded</i>		
Front axle	32.600	71.900
Rear axle	65.100	143.550
Total	97.700	215.450

## Engine

Detroit 16V 71TV, turbo-charged direct injection 2-stroke diesel, 16 cyl.

Max. output 496 kW (674 hp) SAE at 2.100 rpm

Max. torque 2620 Nm (267 kpm) SAE at 1.600 rpm

Bore	108 mm
Stroke	127 mm
Displacement	18,6 dm <sup>3</sup> (litres)
Compression ratio	17:1

## Volumes dm<sup>3</sup> (litres)

Engine, lubricating system	75
Engine, cooling system	150
Gear box	80
Hydraulic system	250
Rear axle	80
Fuel tank	1100

## Transmission

Allison CLBT 6061 • Powershift transmission • Converter with lock-up • Retarder

Torque conversion max. 2,16

## Ratios

1	4,00	4	1,35
2	2,68	5	1,00
3	2,01	6	0,67
Reverse			5,12

## Rear axle

Welded axle housing • Fully floating drive shafts • Final reduction in differential and wheel hubs (planetary gears)

Ratio Overall 17,48:1

## Front axle

Heavy-duty, all-welded axle beam of box design • Carried in suspension system of pneumatic oil type

## Suspension

Front and rear suspension system of pneumatic oil type.

## The Kockum 565 is designed for fast service



The K565 is designed for maximum total economy, and ease of service has high priority. Fast, simple maintenance increases the vehicle's availability. The K565 has thus been designed with reference to both daily maintenance and the inevitable replacement of parts. Simplification and standardization have resulted in a truck that meets the demands for simple service of drivers, mechanics and owners.

During testing of the prototype machine at various work sites, outside service technicians were asked to inspect and critically evaluate the vehicle from the service point of view — and we made good use of their suggestions as to simplification.

### Fast daily maintenance

Coolant can be checked quickly from the roomy service platform, which is also fitted with a safety rail. The hydraulic-oil reservoir, the air cleaner, the dip-stick and the battery are all easy to reach from the ground.

### Easily accessible engine

The engine is easily accessible from the sides or through the counter-balanced bonnet. The gearbox is mounted separately, so that there is plenty of room

for service. Comprehensive standardization of parts reduces the number of maintenance tools to a minimum.

### Simple maintenance of suspension

The four oil-pneumatic suspension units are identical. The simple design includes removable end covers. There are no welding joints.

### Oil-pressure dismantling

The vital bearings that demand a little more maintenance are designed for fast, easy oil-pressure dismantling. This applies to oil-pneumatic suspension units, tipping cylinders, frame connections and linkages.

### Disc brakes on front wheels

The front axle is fitted with highly-effective aviation-type disc brakes. Brake linings can easily be replaced without removing the wheel.

### Compact electrical system

The electrical system is based on printed circuit boards, all of which are installed at an easily accessible control point. This means fewer contacts, simplified trouble-shooting and greater reliability.



Dimensions in mm  
\*Empty \*\*Loaded

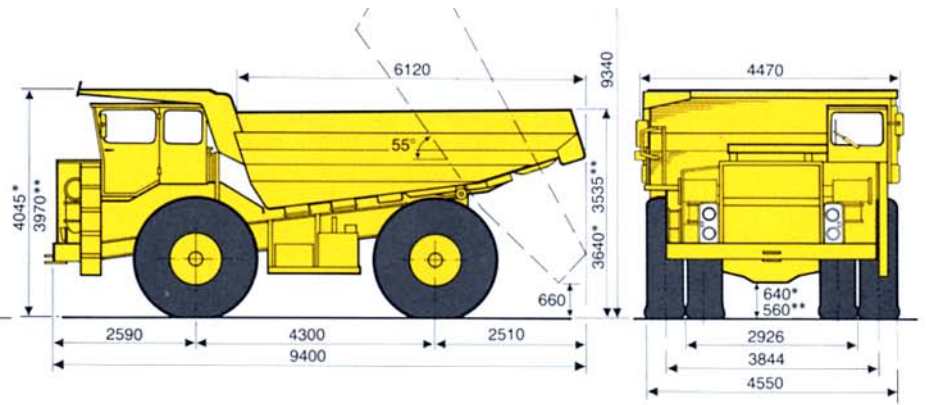

**Wheels**

Rims ..... 17.00—35  
Tyres ..... 24.00—35/42

**Brakes**

*Service brakes 1*

Hydrodynamic brake (retarder) incorporated in transmission

*Service brakes 2*

Dual-circuit air-over-oil actuated  
Front: disc brakes  
Rear: drum brakes

*Parking brake*

Spring actuated, air released drum brake, mounted on the pinion flange

**Steering**

Hydraulic power steering with mechanical feed-back

Pump, gear type, direct-driven from the engine

Steering wheel turns lock to lock ..... 3.5

**Hoist**

Pump, gear type, direct-driven from the gear box via an automatic hydraulically controlled power take-off

2 pcs 3-stage telescopic cylinders,  
2 stages double-acting

Dumping angle ..... 55°  
Dumping time ..... 15 seconds

**Cab**

All-steel cab • Heat and sound insulated • Heater and defroster equipment • Adjustable driver's seat

**Frame**

All-welded box sections with cross members

**Body**

All-welded construction with two external horizontal stiffeners along the entire length of the body. • Exhaust-heated

*Material*

High tensile heat-treated steel  
Yield strength 110 k<sub>p</sub>/mm<sup>2</sup>  
Hardness > 360 Brinell  
Bottom 20 mm  
Sides and front 10 mm  
Weight ..... 10.000 kg

**Electrical system**

Voltage 24 V  
Batteries 2 pcs 12 V, 200 Ah  
Alternator 50 A  
Starter 9,6 kW (13 hp)

*Lights*

Headlights with full and dipped beam • Curve and fog lights • Parking light • Direction indicators • Brake lights • Tail lights • Reversing lights • Hazard flashers • Cab light • Instrument lights

**Standard equipment**

*Instruments*

Hour counter • Air pressure gauge • Oil pressure gauge, engine • Coolant temperature gauge • Oil temperature gauge, gear box • Oil pressure gauge, gear box • Speedometer • Revolution counter

*Control lamps*

Parking brake • Full beam • Direction indicators • Battery charging • Oil pressure, engine • Dump body • Lock-up

*Miscellaneous*

Cold starting device • Wind screen wipers • Wind screen washers • Horn • External rear-view mirrors • Rock ejectors on rear wheels • Electrical engine heater • Safety belt

**Optional equipment**

Body rubber lining • Increased body height • Tachograph • Spare wheel • Emergency steering • Air conditioning • Additional cab heater • Silencer • Electrical heater for the transmission

**Operating data**

Operating speed ..... max. 65 km/h  
Minimum turning radius ..... 8.920 mm  
Minimum swept radius  
left turn ..... 9.960 mm  
right turn ..... 10.100 mm

Dimensions and weights to tolerances of ±3%.  
Specifications subject to change without notice.

**Gradeability — Speed — Rimpull**

(2% rolling resistance)

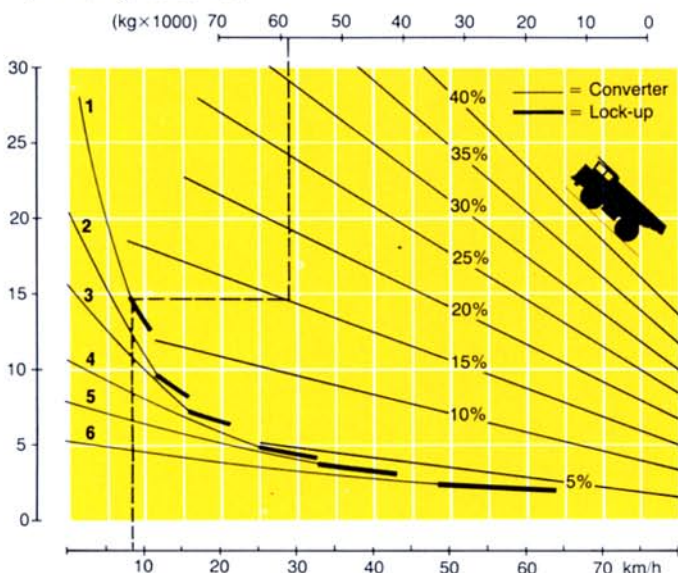

**Retarder chart**

(engine friction incl.)

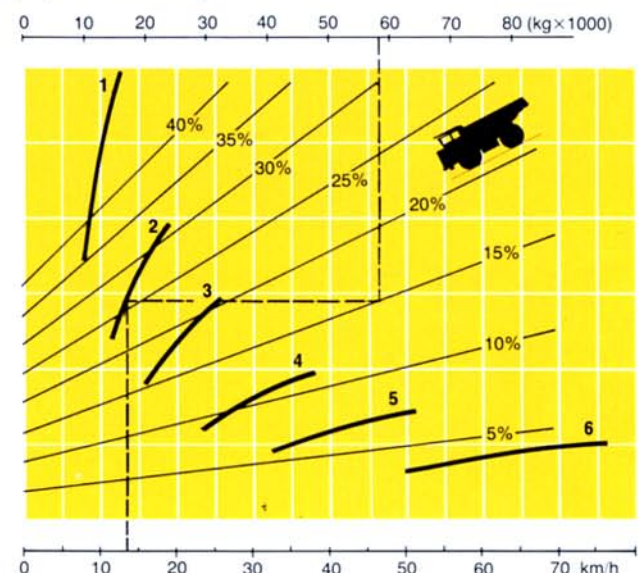



**VOLVO BM**  
VOLVO BM AB ESKILSTUNA SWEDEN

*The manufacturers reserve the right to change specification or design without prior notice.  
Illustrations do not necessarily show the machine in its standard version.*

Ref.No. 21 1 669 1636  
ENGELSKA