

Kockum 442 B



E 170 B

Kockum 442 B

PAYLOAD CAPACITY

Payload	35 tons (32.000 kg)	
Payload volume, struck (SAE)	16.4 m ³	21.5 cu.yd.
heaped 2:1	20.6 m ³	26.9 cu.yd.
heaped 1:1	24.8 m ³	32.5 cu.yd.

WEIGHT DISTRIBUTION		Front axle	Rear axle	Total
Empty	lb	23,350	26,200	49,550
	kg	10,600	11,900	22,500
Loaded	lb	35,700	84,350	120,050
	kg	16,200	38,300	54,500

Dimensions in mm.

- *) Empty
- **) Loaded

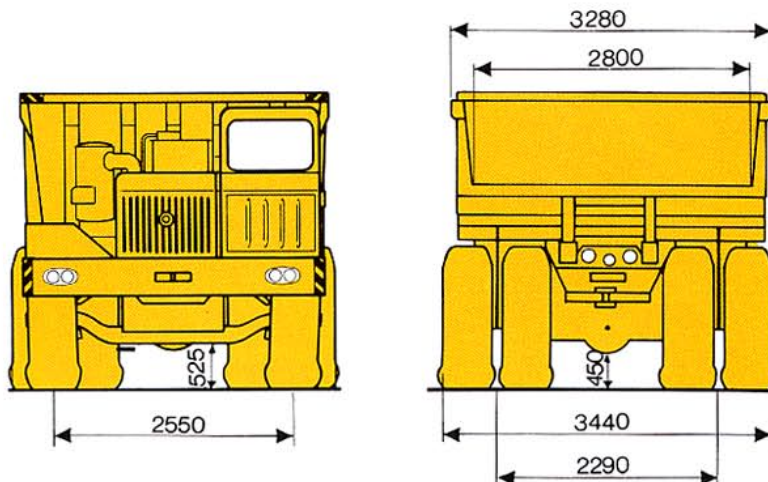
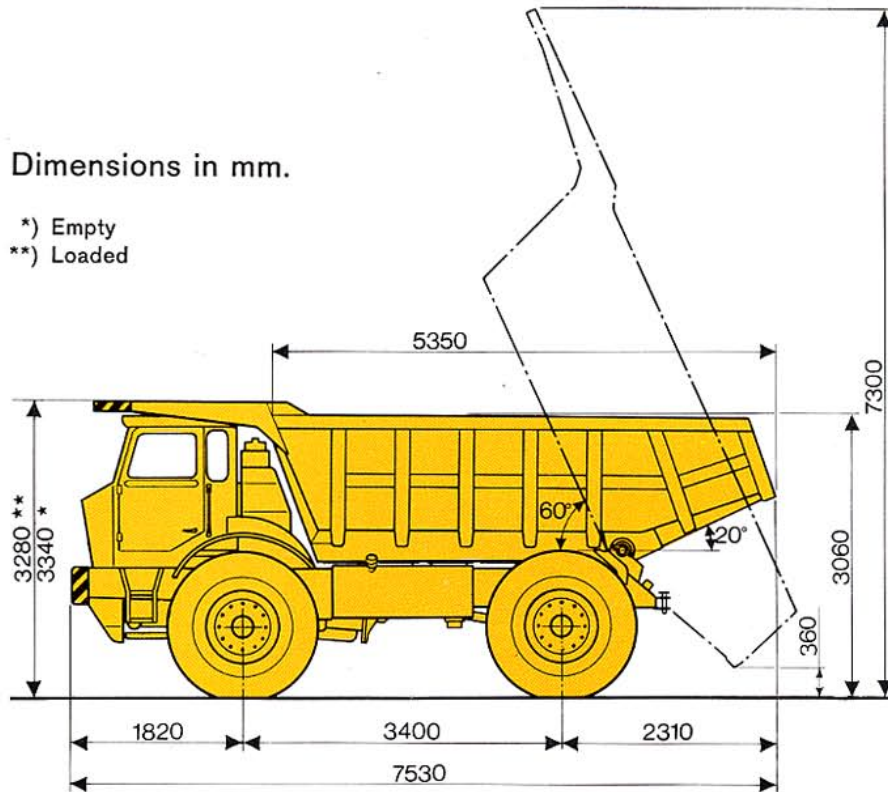

Engine

Type	Scania DS 14 (V8) 8-cylinder, four-stroke direct injection diesel engine with turbo-charger
Max. output	306 kW (416 hp) SAE at 2100 rpm
Max. torque	1575 Nm (161 kpm) at 1400 rpm
Bore	127 mm
Displacement	14,2 dm ³ (litres)
Compression ratio	15.5

Volumes in dm³ (litres)

Engine lub. system	25
cooling system ..	110
Gearbox	55
Hydraulic system	110
Rear axle	47
Fuel tank	415

Converter – gear box

Type	Allison CLBT-754 Automatic gear box Converter with "lock-up" Retarder
Torque conversion	Max. 2,7
Ratios	1 5,18 2 3,19 3 2,07 4 1,40 5 1,00 Reverse 9,45

Rear axle

Type	Fully floating drive shafts. Final reduction in differential and wheel hubs (planetary gears)
Reduction	Total 11.86:1

Front axle

Type	Forged I-section. Carried on leaf springs and reaction rods. Hydraulic shock absorbers and rubber bumpers.
------------	---

Wheels

Rims	13.00–25
Tyres	18.00–25/32 PR

Brakes

Service brakes, 1	Dual-circuit compressed air actuated drum brakes
Service brakes, 2	Hydrodynamic brake (retarder), incorporated in gear box. Max. braking power 295 kW (401 hp)
Parking brake	Separate pneumatically controlled rear wheel brake, spring-loaded. Spring action directly on rear wheels

Steering

Type	Hydraulic power steering with mechanical return system
Pump	Gear type, direct-driven from the engine
Steering wheel turns, lock to lock	4

Hoist

Pump	Gear type, direct-driven from the engine
Hoisting cylinder	3-stage, double-acting telescopic cylinder
Dumping angle	60°
Dumping time	10 seconds

Electrical system

Voltage	24 V
Batteries	Two 12 V batteries, total 150 Ah
Alternator	35 A
Starter	4,8 kW (6,5 hp)
Lights	Headlights with full and dipped beam Curve and fog lights Parking light Direction indicators Brake lights Tail lights Signal light for reversing Reversing lights Cab light Instrument lights Hazard flashers

Frame

Type	Welded I-section with reinforcing cross members
------------	---

Body

Type	All-welded construction with wrap-around ribs. Exhaust-heated
Sides and front	Wear plate of toughened 10 mm steel Hardness 360 Brinell. Yield strength 110 kp/mm ²
Bottom	Wear plate of toughened 20 mm steel. Hardness 360 Brinell. Yield strength 110 kp/mm ²
Weight	6.750 kg

Cab

Type	All-steel cab. Heat and sound insulated Heater and defroster equipment Adjustable driver's seat
------------	---

Other standard equipment

Instruments	Speedometer / Odometer Revolution counter / Hour counter Oil pressure gauge, engine Coolant temperature gauge Oil temperature gauge, gearbox Oil pressure gauge, gearbox Voltmeter
Control lamps	Hazard flashers Parking brake Full beam Direction indicators Battery charging Engine oil pressure Dump body and hoisting hydraulics
Miscellaneous	Cold starting device Windscreen washer Windscreen wipers Horn Buzzer for air pressure Sun visor Hand throttle Compressed air outlet Electrical engine heater Rock ejectors, rear wheels External rear-view mirrors

Optional equipment

Body rubber lining
Spare wheel
Tachograph
Emergency steering

Operating data

Operating speed	Max. 57 km/h (35,4 mph)
Minimum turning radius ..	7,600 mm (24' 11")
Minimum swept radius ..	8,600 mm (28' 2")

Dimensions and weights to tolerances of $\pm 3\%$.
Specifications subject to change without notice.

Main components



- | | |
|----------------------|-----------------------|
| 1. Dump body | 5. Air cleaner |
| 2. Hoisting cylinder | 6. Cab |
| 3. Frame | 7. Engine compartment |
| 4. Air tanks | 8. Batteries |

Power train

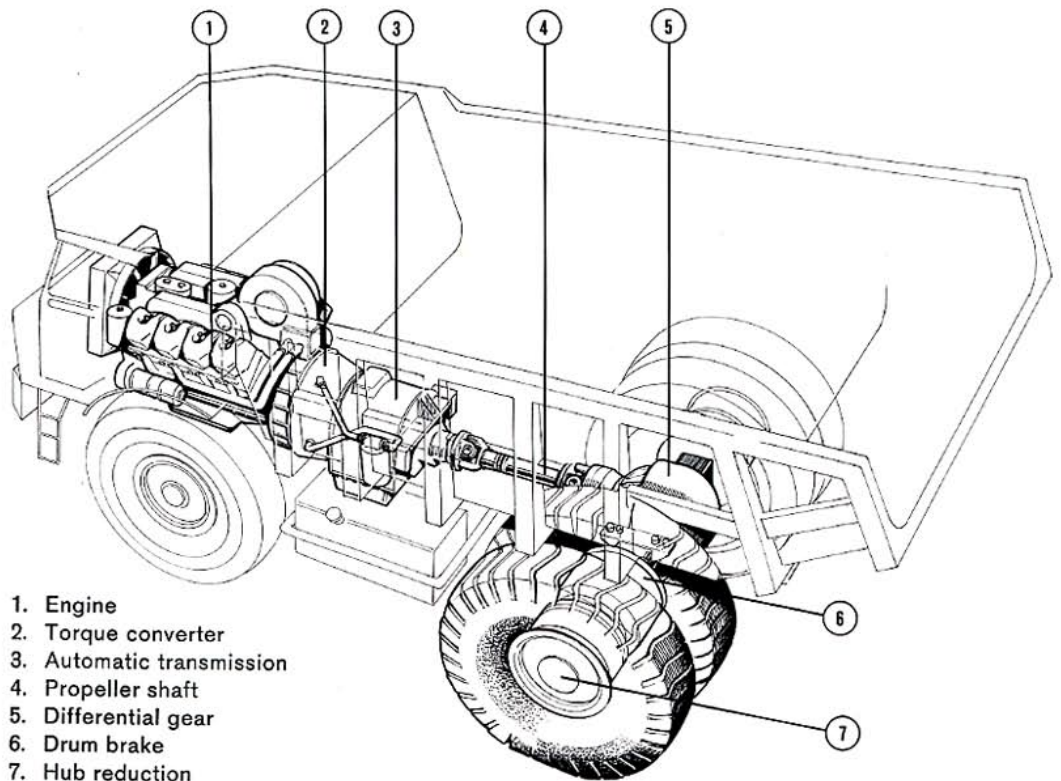

- | |
|---------------------------|
| 1. Engine |
| 2. Torque converter |
| 3. Automatic transmission |
| 4. Propeller shaft |
| 5. Differential gear |
| 6. Drum brake |
| 7. Hub reduction |

Engine

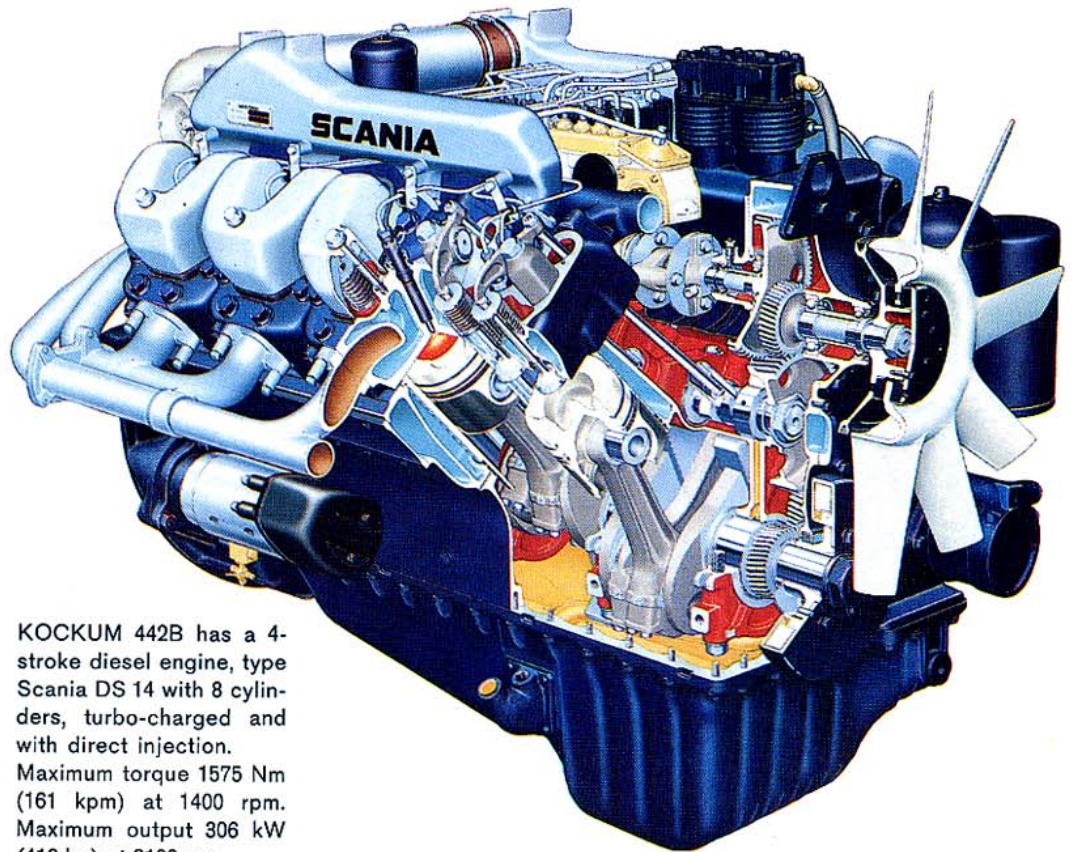

KOCKUM 442B has a 4-stroke diesel engine, type Scania DS 14 with 8 cylinders, turbo-charged and with direct injection. Maximum torque 1575 Nm (161 kpm) at 1400 rpm. Maximum output 306 kW (416 hp) at 2100 rpm.

CYLINDER BLOCK	Cylinders are placed 4 by 4 in 90° V-form. Block and crankcase cast in one piece of alloy cast iron. Replaceable wet-type cylinder liners of centrifugally cast special iron.
CYLINDER HEADS	Each cylinder head is covering one cylinder and is fastened with 8 bolts. Steel plate gasket. Valve seats made of special alloy.
VALVES	Made of heat-resistant steel with stellite-faced heads. Chromiumplated valve stems with replaceable hardened steel caps. Double springs to every valve.
CAMSHAFT	Carried in 6 bushings in the cylinder block. Camshaft, cooling water pump, cooling fan, injection pump and lubricating oil pump along with other ancillaries such as hydraulic pump and air compressor are direct driven from the crankshaft through silent-running helical gearing. On the front left hand side there is an extra power take-off. SAE standard. Gear ratio 1:1. Max. output 60 bhp.
PISTONS	Groove for the top compression ring reinforced with a cast-iron insert. Compression rings and oil scraper ring of alloy cast-iron. Top compression ring has a convex chromiumplated wearing surface. Floating-type. Inside of piston cooled by lubricating oil sprayed from a nozzle in the cylinder block.
CRANKSHAFT	Main bearings with replaceable bearing shells, consisting of a thin steel body coated with lead-bronze and surfaced with a layer of lead-indium. Viscous-type vibration damper at the front.
CONNECTING RODS	The small-end of the connecting rod is wedge-shaped to give a large bearing surface.
FLYWHEEL	Balanced and made of cast iron.
LUBRICATION	Lubrication oil is forced by a gearwheel pump to the lubricating points. Oil pressure controlled by a relief valve. Electrical contact in the lubricating system lights a warning lamp if the oil pressure gets too low. The lubricating oil is cleaned before it reaches the pump by a strainer in the oil sump and after the pump by a cleaner unit, consisting of a cyclone and a centrifugal cleaner. Extra oil filter for the turbo-charger. Oil cooler connected to the engine cooling system.
COOLING SYSTEM	Gear-driven centrifugal type water pump. Two parallel mounted wax-thermostats. Gear-driven 10-blade cooling fan.
FUEL SYSTEM	Five-hole injectors with edge filters. The injection pump camshaft is shaped to prevent the engine from running backwards. A smoke limit device reduces the quantity of fuel injected at start and low engine revolutions. A cold starting device provides extra fuel for starting in low temperatures, and has an automatic cut-out.
TURBO-CHARGER	Consisting of a single-stage radial turbine and a single centrifugal compressor. The turbine is driven by the exhaust gases, so that its speed will automatically adjust to the engine load. The turbo-charger is cooled and lubricated by oil from the engine lubricating system, via a separate oil filter.

Automatic transmission

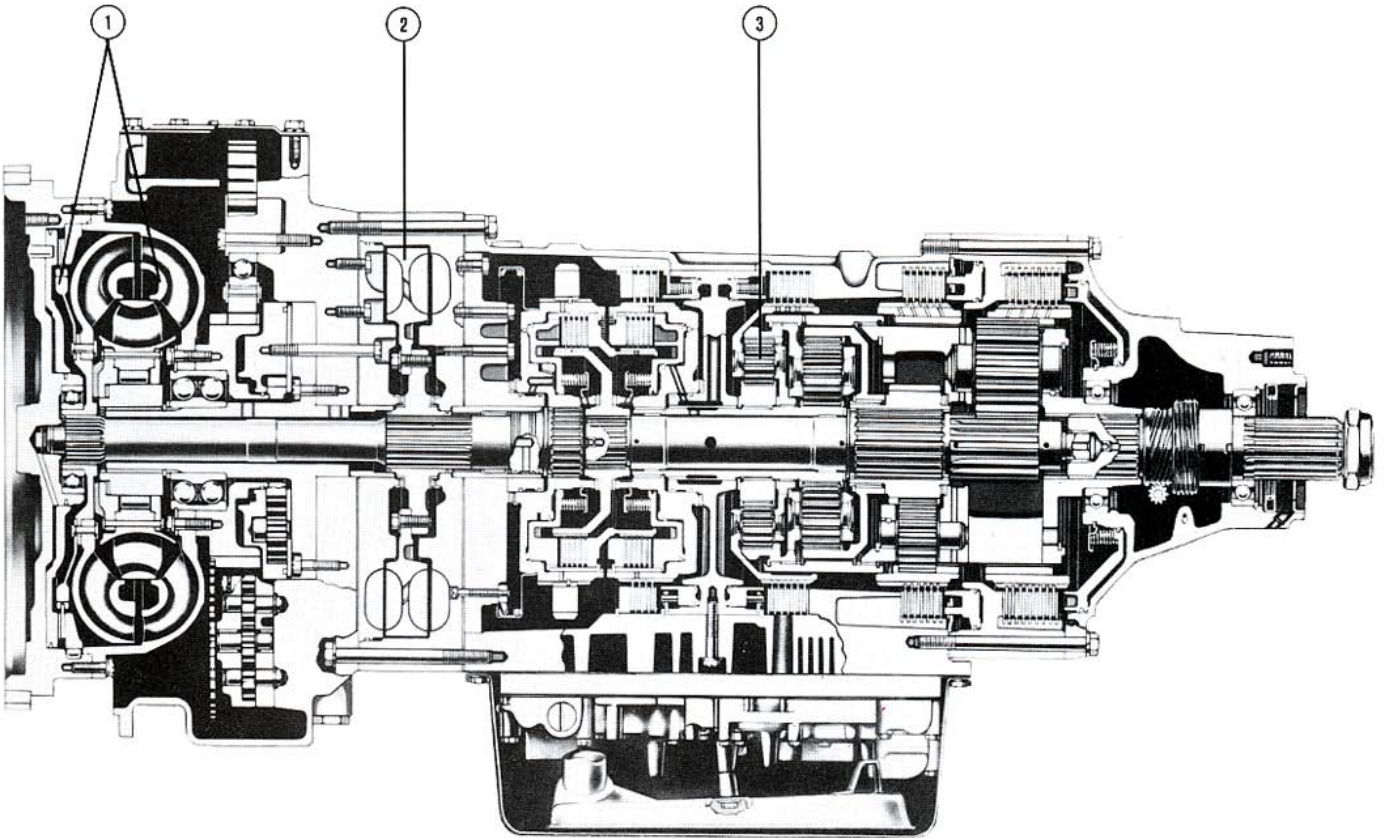

ALLISON CLBT 754

- C for Converter (1)
- L for Lock-up (1)
- B for Retarder Brake (2)
- T for automatic Transmission (3)

KOCKUM 442B is as standard equipped with an Allison CLBT-754 fully automatic gearbox, directly flanged to the engine flywheel housing.

The CLBT-754 provides built-in inhibitors to protect against harmful downshifts, excessive engine overspeeding and shifts to reverse at excessive speeds.

The converter has two functions. It multiplies torque for maximum rimpull and also works as a fluid coupling. It is equipped with automatic lock-up, i.e. with direct drive efficiency in each gear for higher speed.

The automatic gearbox eliminates costly mechanical clutch repairs or replacements and protects expensive power train components, reducing non-productive downtime.

The CLBT-754 has:

- Five forward ranges, one reverse
- Mechanical shift modulation control
- Driver controlled hydraulic retarder

The retarder is the main service brake and is incorporated in the transmission. The retarder consists of a bladed rotor, operating between vaned stators. A foot-operated valve fills or exhausts the cavity in which the rotor operates. When the retarder is applied the rotor runs in oil and absorbs power. When released the oil is exhausted and the rotor runs free. Thus you brake with oil, instead of wearing the brake linings.

The retarder is especially useful in rugged applications, such as down-hill hauls in open pit mining and construction work, where severe grades are encountered. It improves braking capability and service brake life, gives better downhill stability and increases engine life.

Axles

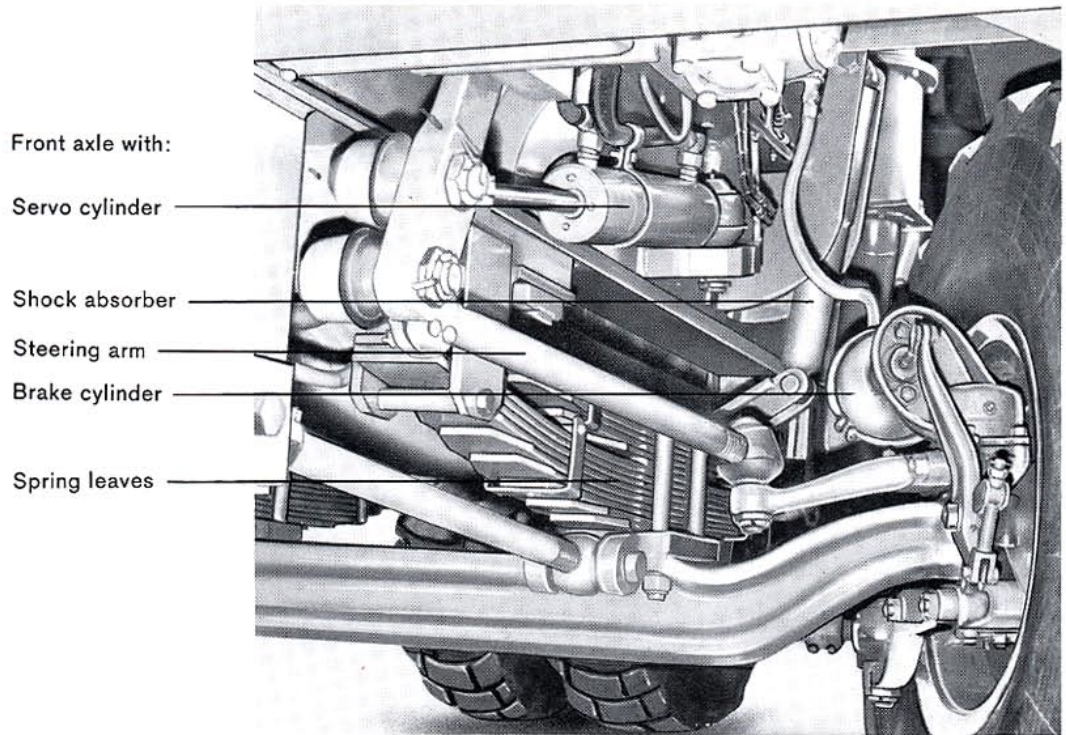

Front axle with:

Servo cylinder

Shock absorber

Steering arm

Brake cylinder

Spring leaves

FRONT AXLE

The front axle is forged in one piece. It is fastened to the springs by four bolts and is fixed to the frame by two reaction rods. Each main spring is laterally fixed to the corresponding frame beam.

The spring assembly consists of main and auxiliary springs which, together with two strong rubber buffers, provide a comfortable ride whether the dump truck is loaded or not. Furthermore the front axle has a hydraulic shock absorber on each side.

REAR AXLE

Power is transmitted to planetary final drives in wheel hubs, driven by fully floating shafts from hypoid differentials. The rear axle is attached to the frame and has no springs, which offers certain advantages, such as:

- Increased stability
- Lower loading height
- Lower weight, which means increased payload capacity
- No maintenance.

Wheels

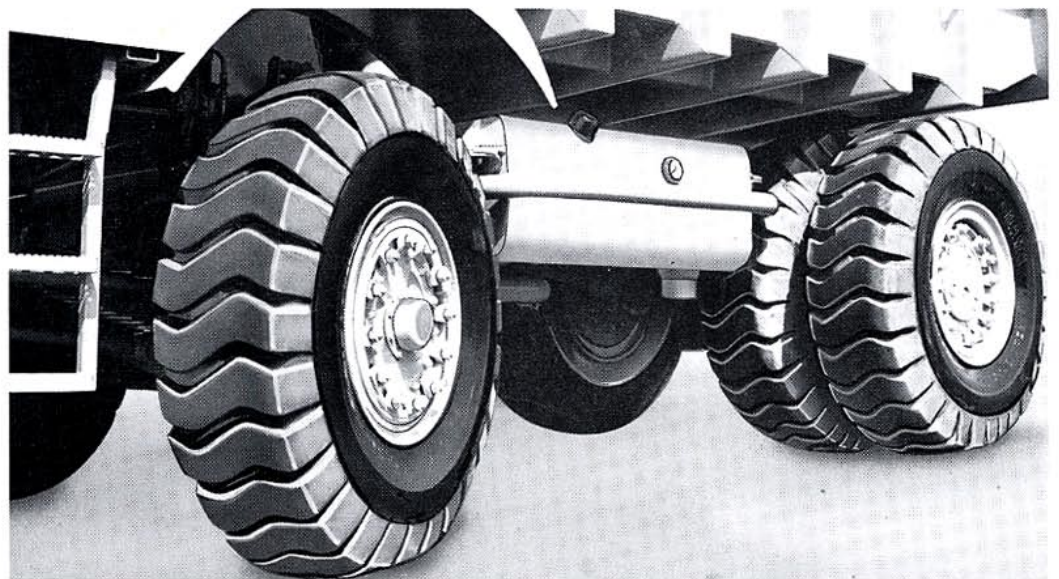

KOCKUM 442B wheels are of the same size front and rear. Tyre size 18.00-25/32 PR. Alternative tyres can be supplied on request. The excellent ground clearance, max. 450 mm, is always a big advantage on site or quarry work.

The rear dual wheels are equipped with rock ejectors to remove stones stuck between the wheels.





Steering

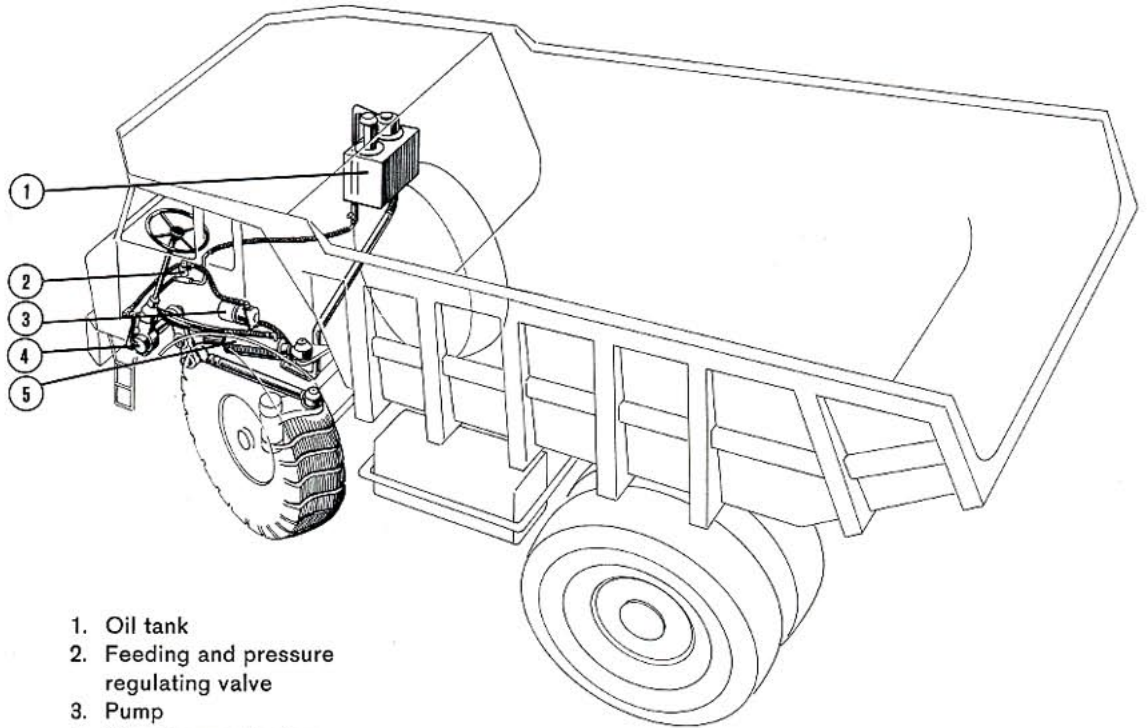

1. Oil tank
2. Feeding and pressure regulating valve
3. Pump
4. Steering mechanism
5. Steering cylinder

PUMP

The gear-type pump of the steering system has an output of 57 dm³/min (litres/min) at 1800 rpm and is directly powered by the engine.

The guiding device directs the oil flow to one or the other side of the piston of the double-acting steering cylinder.

The guiding device thus works as a control valve, but it also has mechanical transmission to the axle.

REGULATING VALVE

KOCKUM 442B has a smooth servo action on the steering, independent of the engine revolutions. Through the regulating valve the oil flow is reduced to 40 dm³/min (litres/min), which the pump produces at low revolutions. The pressure is reduced to 100 bar (kp/cm²).

STEERING MECHANISM

The steering mechanism works via a hydraulic cylinder operated by turning the steering wheel, hydraulic power being transmitted to the servo cylinder and steering arm simultaneously. The steering mechanism is also connected to the steering arm mechanically.

Emergency steering can be installed for extra safety.

Electrical system

KOCKUM 442 B has an alternator with a capacity of 35 A and an alltransistorized charging regulator.

The truck has a 4,8 kW (6,5 hp) electric starter.

The capacity of the batteries (two 12 V batteries connected in series) is 150 Ah. Voltage 24 V.

Dual circuit braking system

1. Retarder brake
2. Brake pedal
3. Parking brake control
4. Compressor
5. Braking cylinder, retarder
6. Air tanks

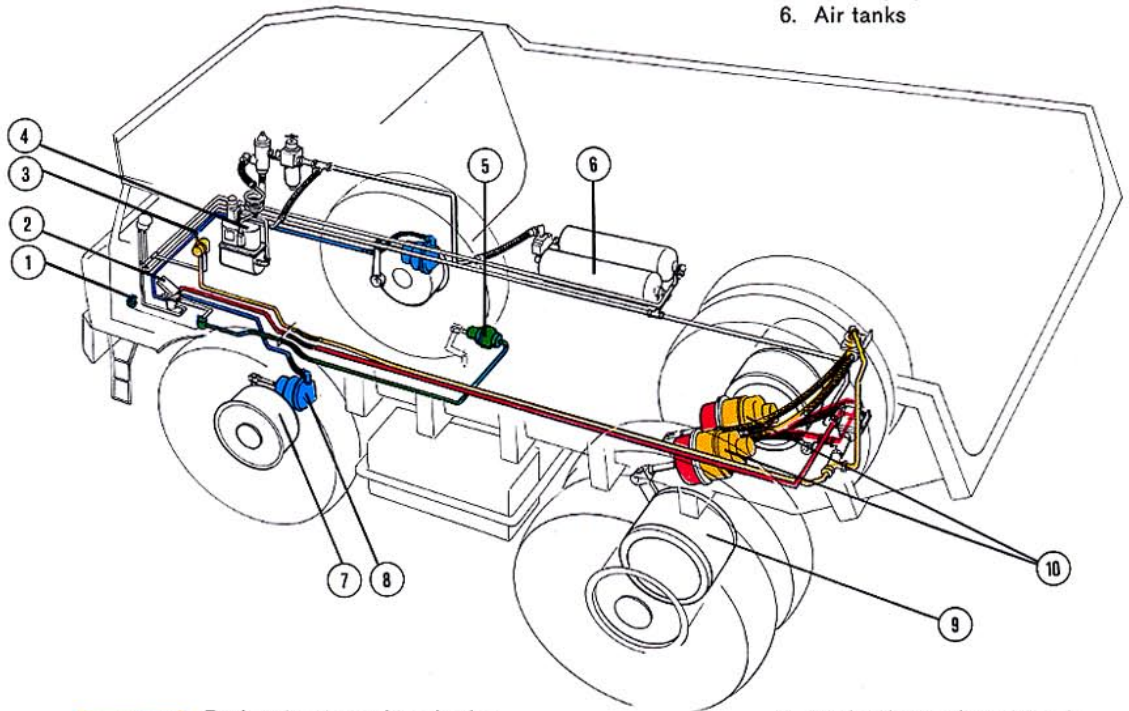

- Brake circuit, parking brake
- Brake circuit, front wheels
- Brake circuit, rear wheels
- Retarder

7. Brake drums, front wheels
8. Braking cylinder, front wheels
9. Brake drums, rear wheels
10. Braking cylinders, rear wheels

SERVICE BRAKES

KOCKUM 442B has dual-circuit drum brakes, pneumatically operated, with separate circuits for front and rear wheels.

The rear wheel brakes are controlled by a relay valve, which leads the air from the air tank directly to the brake chambers, thus shortening the time for the brakes to become effective.

The hydrodynamic brake, the retarder, is incorporated in the transmission. It is extremely useful in rugged applications, where severe grades are encountered. It improves braking capability and service brake life, gives better downhill stability and increases engine life.

A buzzer in the cab indicates low air pressure in the braking system.

PARKING BRAKES

The parking brake is separately operated by compressed air and acts directly on the rear wheels.

The braking cylinders on the rear axle have a built-in fail-safe parking brake. As long as the air pressure is lower than 70 lbs p.s.i./5 bar (kp/cm²) the brakes remain engaged and the control lamp for the parking brakes stays alight.

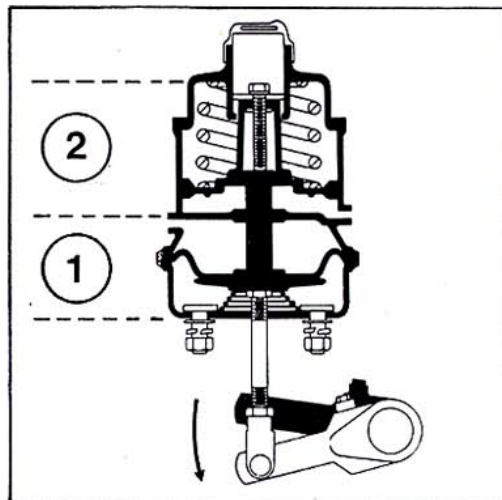

- Braking cylinder, rear axle
1. Cylinder for drum brakes
 2. Cylinder for parking brake.

Hoist

1. Hoisting control
2. Hoisting valve
3. Hydraulic pump
4. Filter
5. Hydraulic oil tank
6. Hoisting cylinder

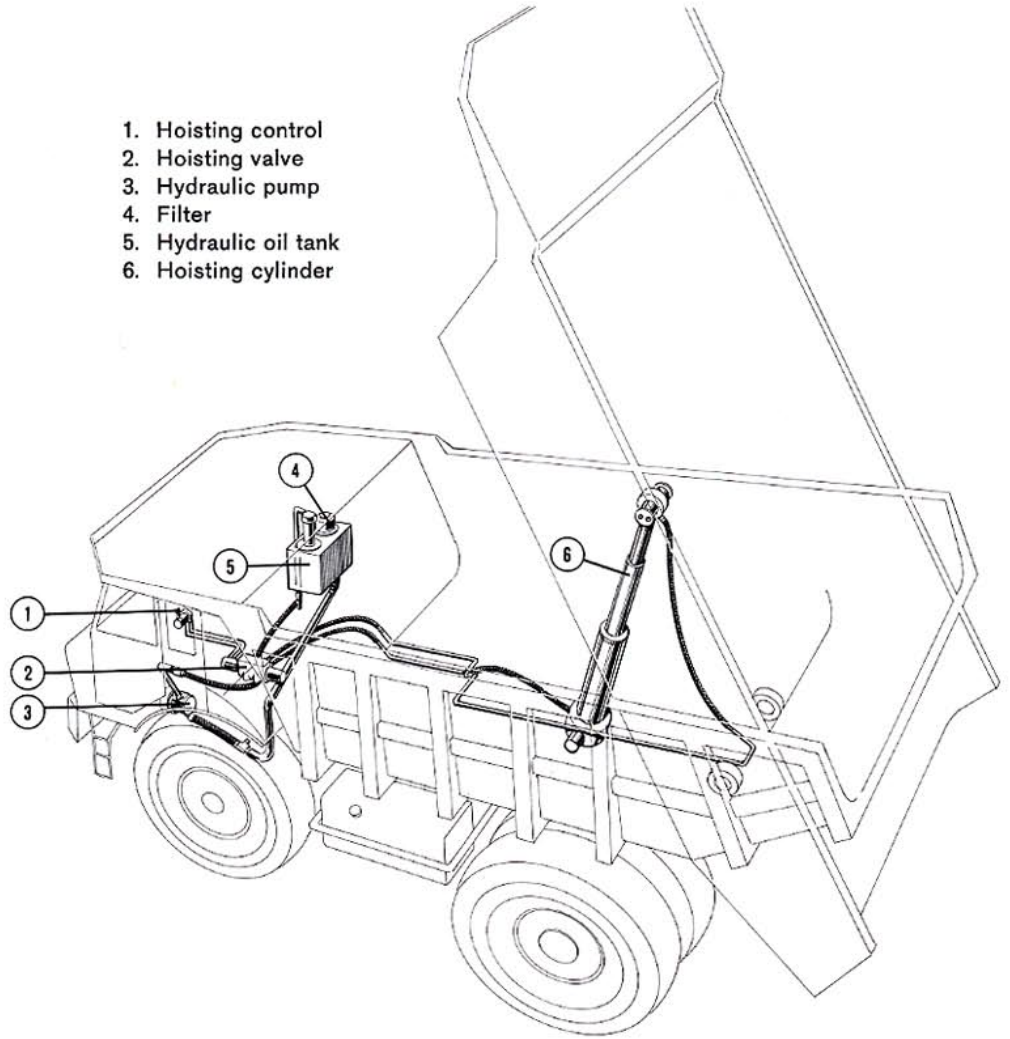

HYDRAULIC PUMP

The pump is of gear type and direct-driven from the engine. Output 150 dm³/min (litres/min) at 1800 rpm.

CONTROL VALVE

The control valve has a primary and a secondary relief valve. It controls the operating pressure and protects the system against overloading.

HOISTING CYLINDER

KOCKUM 442B has a 3-stage telescopic cylinder where the two inner stages are double-acting. When the cylinder is totally raised the oil goes through a discharge valve direct to the tank.

FILTER

On the return flow line to the oil tank there is a filter, equipped with a replaceable insert and a strong magnetic rod. The magnet extracts all steel particles, thus reducing wear on the hydraulic components and prolonging their operating life.

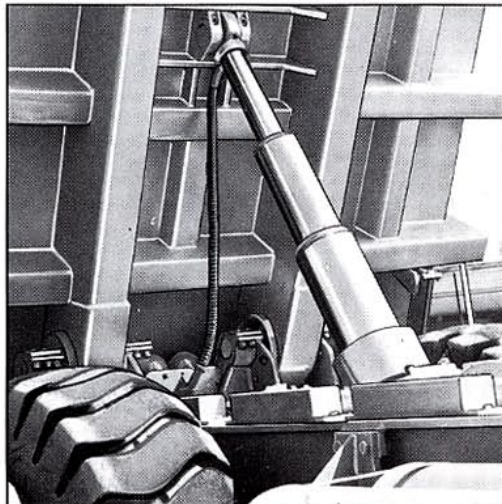

Hoisting cylinder

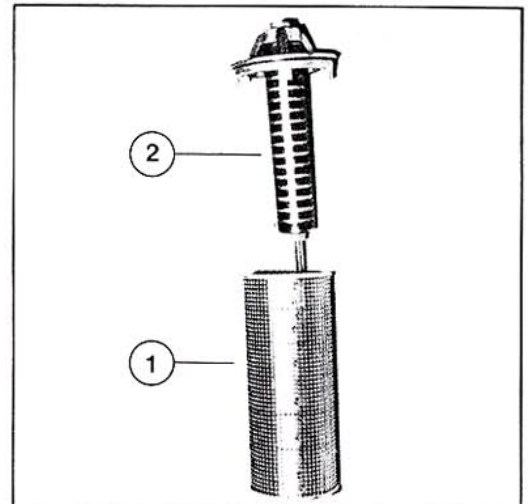

1. Filter insert
2. Magnetic rod

Body



Rock body is standard on the KOCKUM 442B. The body is made of special-alloy, abrasion resistant steel: yield strength 110 kp/mm²; hardness 360 Brinell, thickness bottom 20 mm, sides 10 mm.

All-welded construction with wrap-around ribs.

Payload volume: struck SAE 16,4 m³, heaped 2:1 20,6 m³. With full load, 35 tons, the dump body is tipped to 60° in 10 seconds. The body is designed for one-point loading and holds the loads even on steep uphill hauls.

Exhaust, piped through the ribs, heats the body for cleaner dumping of wet, sticky material. Heated body is standard on Kockum 442B.

As optional equipment, the 442B can be equipped with body rubber lining.

Cab

KOCKUM 442B has an all-steel cab, fully separated from the engine compartment. The cab rests on four vibration-absorbers. Safety glass throughout. The large windows and the high, front-mounted cab ensure excellent visibility.

The cab is noise insulated and is fitted with heating and defrosting equipment, built for use also in very low temperatures.

A separate fresh air intake accounts for good ventilation.

The driver's seat is of the latest design for maximum comfort. The cab interior is so designed that all controls and levers are within easy reach, for good vehicle control. The floor is even.

Windscreen washer and windscreen wipers are standard.

Radio is available as optional equipment.

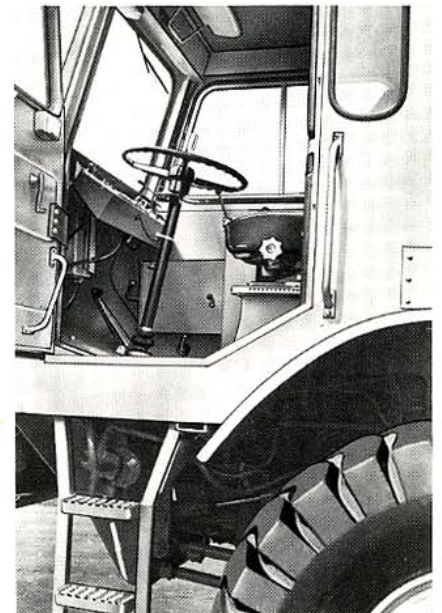

Instruments and controls

1. Windscreen wiper
2. Cab heating
3. Headlights
4. Parking lights
5. Revolution counter/hour counter
6. Air pressure gauge
7. Speedometer/odometer
8. Hazard flashers
9. Windscreen washer
10. Instrument panel lights
11. Control lamp, engine oil pressure
12. Control lamp, battery charging
13. Control lamp, direction indicators
14. Control lamp, full beam
15. Control lamp, parking brake
16. Control lamp, dump body and hoisting hydraulics
17. Key switch
18. Stop lever
19. Hand throttle
20. Fan (heater)
21. Coolant temperature gauge, engine
22. Oil pressure gauge, engine
23. Voltmeter
24. Oil temperature gauge, gearbox
25. Oil pressure gauge, gearbox
26. Lighter
27. Retarder brake
28. Direction indicators, headlights, full and dipped beam lever
29. Horn
30. Brake pedal
31. Throttle pedal
32. Hoist lever
33. Gear lever
34. Parking brake lever

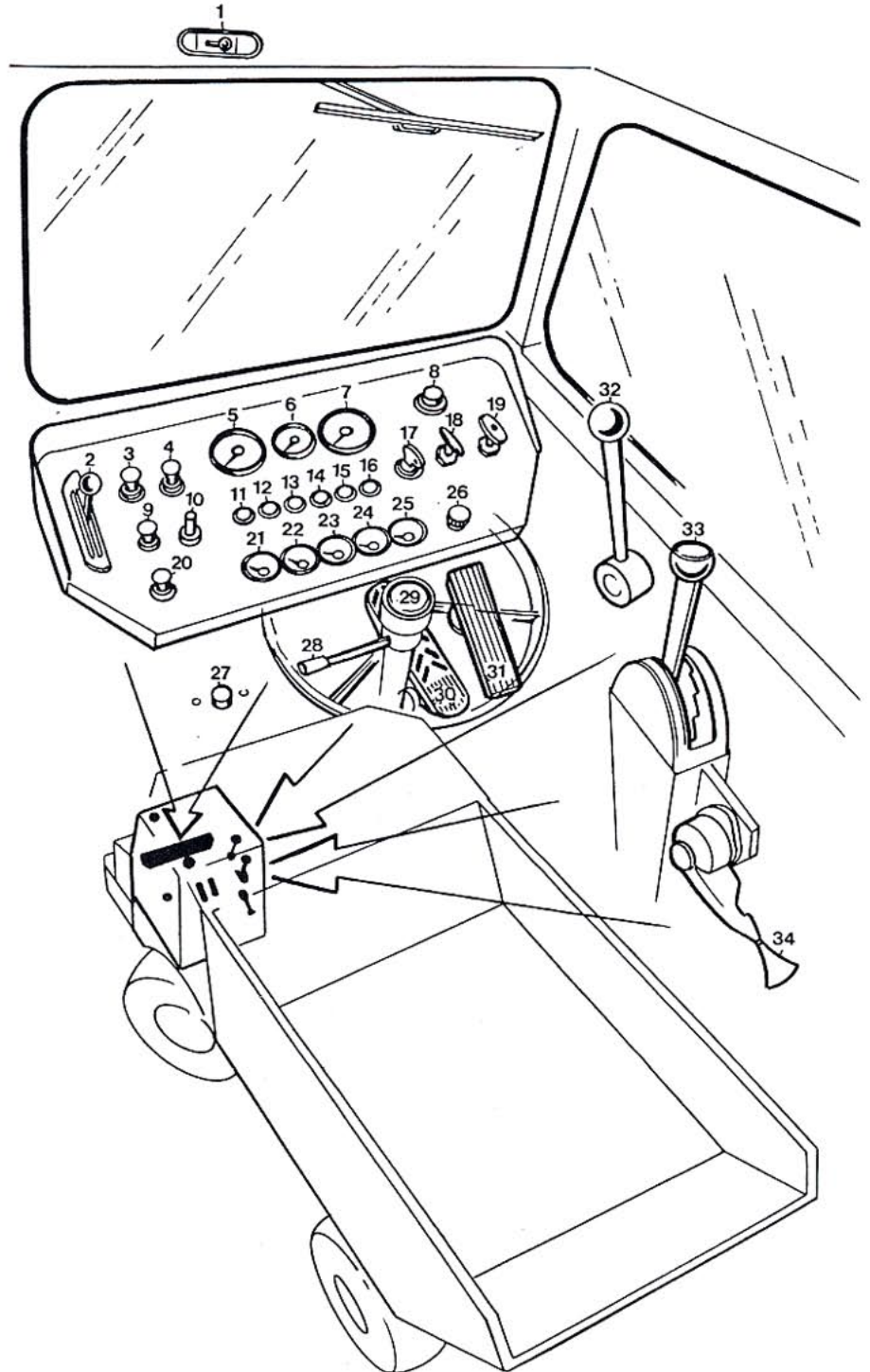

Frame

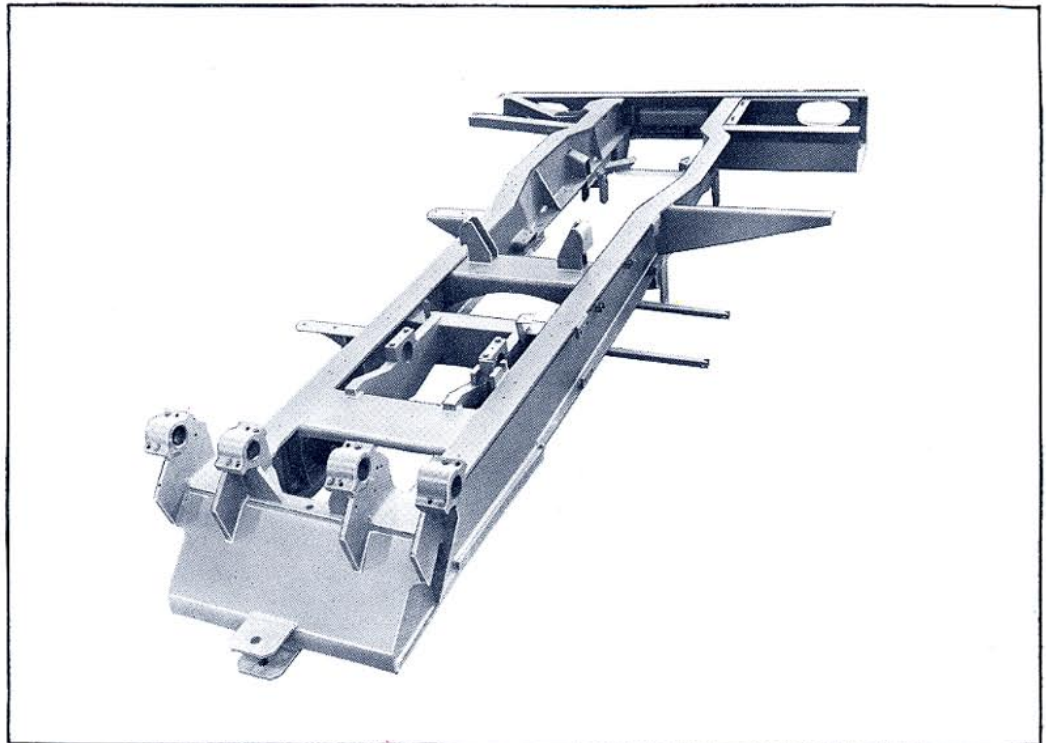

The frame is made of welded I-sections with reinforcing cross members. The box-type construction at the front protects the front axle and the steering mechanism.

The fuel tank is attached to the left side of the frame. It contains 415 litres. On the right side there are two air tanks, 60 litres each.

Gradeability – Speed – Rimpull

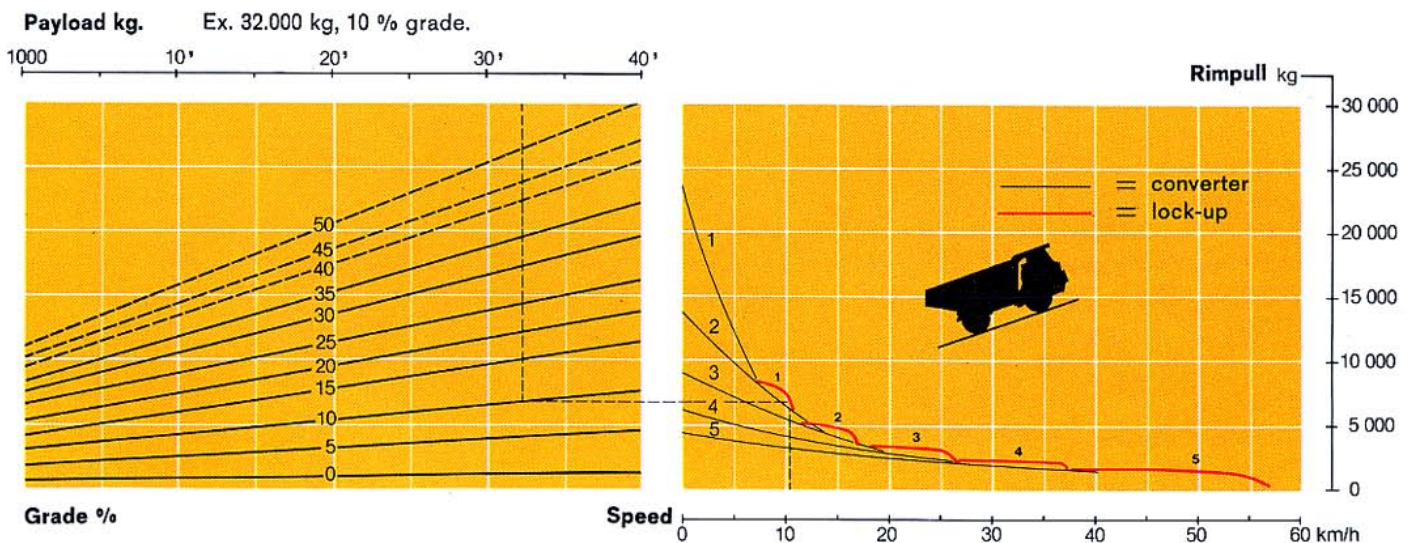

The values include a rolling resistance of 2 %.



Kockum 442 B – for efficient and profitable haulage

- Automatic transmission for less driver fatigue
- Rock body of high tensile strength steel for longer operating life
- Compact design for all-round application
- Low net weight for more payload
- Low loading height, for fast loading times
- Short swept radius, for exceptional manoeuvrability
- Sturdy engine for economic and easy service
- Fully floating drive shafts, for low maintenance costs and reliable operation
- Safe, comfortable cab with optimum visibility for operator comfort and vehicle control

 **Kockum Landsverk**

Box 512, S-261 24 Landskrona, Sweden
Telephone 0418-770 00, Telex 72034 kocland s