



Volvo Construction Equipment

ABG2820

Volvo Tracked Pavers 1.5-4.0 m 63 kW



A passion for performance

At Volvo Construction Equipment, we're not just coming along for the ride. Developing products and services that raise productivity – we are confident we can lower costs and increase profits for industry experts. Part of the Volvo Group, we are passionate about innovative solutions to help you work smarter – not harder.

Helping you to do more

Doing more with less is a trademark of Volvo Construction Equipment. High productivity has long been married to low energy consumption, ease of use and durability. When it comes to lowering life-cycle costs, Volvo is in a class of its own.

Designed to fit your needs

There is a lot riding on creating solutions that are suited to the particular needs of different industry applications. Innovation often involves high technology – but it doesn't always have to. Some of our best ideas have been simple, based on a clear and deep understanding of our customers' working lives.



You learn a lot in 180 years

Over the years, Volvo has advanced solutions that have revolutionized the use of construction equipment. No other name speaks Safety louder than Volvo. Protecting operators, those around them and minimizing our environmental impact are traditional values that continue to shape our product design philosophy.

We're on your side

We back the Volvo brand with the best people. Volvo is truly a global enterprise, one that is on standby to support customers quickly and efficiently – wherever they are.

We have a passion for performance.



Volvo Trucks



Renault Trucks



Mack Trucks



UD Trucks



Volvo Buses



Volvo Construction Equipment



Volvo Penta



Volvo Financial Services

ABG2820 - unique in its class

The ABG2820 is an all-round talent for small to medium paving applications. Although a compact paver, it includes many of the state-of-the-art features already incorporated in the larger models. The powerful propulsion system enables the paver to push any feed truck and the EPM control panel offers Volvo's unique operating comfort.

Fields of application

The ABG2820 is the economic solution when paving the following applications: footpaths, cycle tracks and rural roads, parking lots and access roads, sports arenas and recreation grounds, landscape projects, urban roads, resurfacing work.

Low operating costs

The ABG2820 is designed to require very low maintenance. Lifetime lubricated crawler tracks with automatic tensioning system and maintenance-free bearings for the conveyor, the screed tamper and vibrator reduce maintenance time and costs to a minimum.

B Excellent operating comfort

The operator's platform offers excellent all-round vision. The control panel and seat can cross-slide as a complete unit to both sides of the paver and rotate through 30° in its end positions.

A Environmentally friendly engine with low fuel consumption

The COM III certified diesel engine runs quietly and is environmentally friendly. Low fuel consumption together with the large fuel tank capacity permit non-stop paving operations - depending on job-site conditions - of up to 12 hours without refuelling.

E

F

G

A

C

B





B Superior view of material flow

The cross-sliding, rotating operator's seat and panel unit and a high sitting position provide an excellent view of the flow of paving material.



C Latest generation of EPM

The Electronic Paver Management is a well-proven serial CAN bus control system with a modern operating panel which clearly displays all paver functions, settings and operating status. No other system on the market offers such intuitive operation, and extensive options for storing and analysing machine data.



D Variomatic Screed VB 30

The VB 30 tamping and vibrating screed with patented screed guide system infinitely extends to double the basic width (1.5 - 3.0 m). Screed extensions increase the paving width up to 4.0 m.



E Optimum mobility

A high transport speed of 6 km/h and extraordinary manoeuvrability facilitate moving the paver around the jobsite. Individually operated hopper wings (option) and swivelling truck buffer rollers permit paving right up to lateral obstructions.



F Efficient mix conveyor system

The well dimensioned hopper has a capacity of 6 t and can be charged by large dump trucks without any problem. Due to individual hydrostatic drives for each conveyor and each auger the mix distribution is individually adapted to the requirements of each screed side.



G Travel drive with high tractive force

The electronically controlled travel drive ensures a uniform propulsion, accurate straight ahead travel, exact cornering and soft start. These are optimum prerequisites for a smooth and even mat. The high static friction of the replaceable thick rubber track pads ensures a very high tractive power.

Dimensions

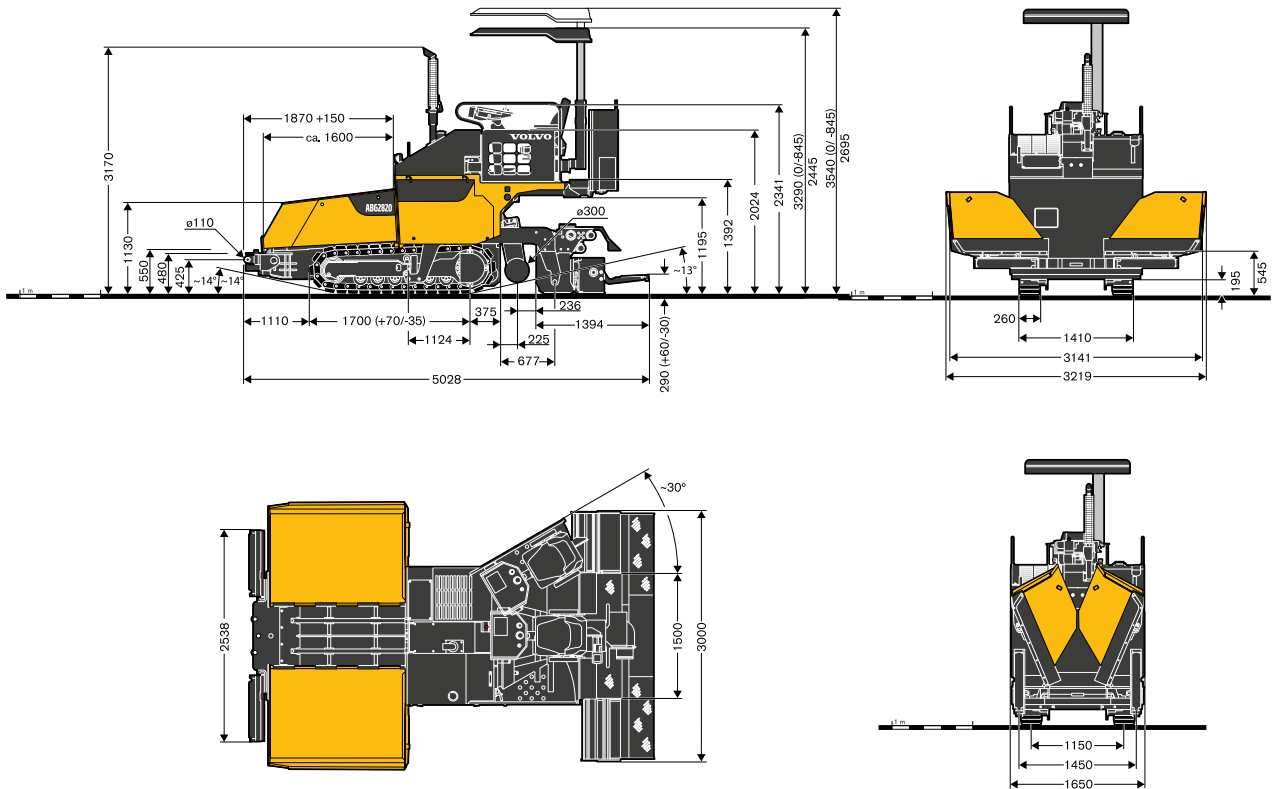

Specifications

| | | | |
|--------------------------------------|--|-----------|------------------------|
| Engine (Diesel) | Model | | Deutz TD2011L04 |
| | Output | kW / hp | 63 / 86 @ 2 500 rpm |
| | Coolant | | Liquid |
| | Fuel tank capacity | l | 125 |
| | Exhaust emission | | COM IIIA /EPA Tier III |
| Paving | Output (theor.) ¹ | t/h | 330 |
| | Mat thickness (max.) | mm | 250 |
| Speeds | Paving | m/min | 29 |
| | Transport | km/h | 6 |
| Crawler unit | Length | mm | 1 680 |
| | Width (track plates) | mm | 260 |
| Mix conveyor system | Hopper capacity | t | 6.0 |
| | Conveyors | | 1 |
| | - Conveyor speed | m/min | 21 |
| | Augers | | 2 |
| | Auger speed | 1/min | 81 |
| Auger diameter | mm | 300 | |
| Electrics | | V | 24 V system |
| Transport dimensions | Width x Length x Height | mm | 1 650 x 5 028 x 2 445 |
| Weights² | Tractor unit | kg | 7 880 |
| Screed VB 30 | Basic width and adjusting range | m | 1.50 - 3.00 |
| | Max. paving width with extensions | m | 4.0 |
| Operating weights² | at 1.50 - 3.00 m paving width | kg | 1 610 |
| | at 4.00 m paving width | kg | 1 870 |
| Sound Level | Sound Pressure Level at Driver's Ear, acc. to ISO 11201 | LpA dB(A) | 85 (with VB30 screed) |
| | Guaranteed Sound Power Level, acc. to Directive 2000/14/EC | LwA dB(A) | 105 (with VB30 screed) |

¹ The actual paving output depends upon the mat thickness, the paving width and paving speed and will vary according to paving conditions prevailing on your jobsite. Please approach us and we will be pleased to assist you in calculating the paving output for your particular paving project.

² All weights are approx. weights without options.

Equipment

Standard ● Optional ○

Partial listing of standard equipment and available options

| | | | |
|--|---|--|---|
| Deutz Diesel engine, COM IIIA/EPA Tier III | ● | Screed anti-climbing lock | ○ |
| Electronic Paver Management (EPM2) | ● | Screed assist | ○ |
| Operator's panel and seat unit, laterally slewable and rotatable | ● | Half lane paving kit | ○ |
| Deluxe seat with heating | ○ | Mechanical auger height adjustment | ● |
| GRP (Glass-fibre reinforced plastic) all-weather roof | ○ | Hydraulic auger height adjustment | ○ |
| Electronic drive control | ● | Levelling systems | ○ |
| Lifetime lubricated crawler track rollers | ● | Electric switch cabinet | ● |
| Forged and hardened crawler track links | ● | Four working lights | ● |
| Steering system with individual hydrostatic drives | ● | Sound insulation | ● |
| Individually swivelling truck buffer rollers | ● | Anti-vandalism kit | ● |
| Front cross beam longitudinally adjustable | ● | Battery master switch | ● |
| Individual operating hopper wings | ○ | Two external control panels for the paving screed | ● |
| Front hopper wall | ○ | Tool kit | ● |
| Hydrostatic drives for conveyors and augers | ● | Particle filter (according to BUVAL directions) | ○ |
| Single conveyor | ● | Two additional rear lights | ○ |
| Two independent conveyors | ○ | Warning beacon | ○ |
| Reversible conveyor | ○ | Auxiliary control panel | ○ |
| Maintenance-free conveyor bearings | ● | Heavy-duty spray cleaning gun | ○ |
| Proportional ultrasonic auger control according to material requirements | ○ | Special paintwork (according to RAL colour code, excluding metallic paintwork) | ○ |
| Reversible direction of auger rotation | ○ | | |
| Screed lock | ● | | |

SELECTION OF VOLVO OPTIONAL EQUIPMENT

Two Independent Conveyors



With the two independent conveyors the flow of material can be adapted to unequal requirements of each screed side (e.g. when paving along a wall).

Individually Operated Hopper Wings



Separately controlled hopper wings facilitate feeding from the side by wheel loaders etc. when paving close to an obstruction.

Front Hopper Wall



If the jobsite conditions don't permit the material feed by rear dump trucks the hopper can also be charged from the side (by conveyor, wheel loader etc.). The front hopper wall avoids spilling material in front of the paver.

Not all products are available in all markets. Under our policy of continuous improvement, we reserve the right to change specifications and design without prior notice. The illustrations do not necessarily show the standard version of the machine.

VOLVO

Volvo Construction Equipment

www.volvoce.com