

C80A/C86A

 **CHAMPION**® **C-Series**
MOTOR GRADERS



MODEL	C80A	C86A
Configuration	Articulated	All Wheel Drive
Operating Weight*	15,320 lbs (6 949 kg)	15,870 lbs (7 205 kg)
Horsepower (kW)	76 (55)	100 (75)

* Typically equipped: see specifications for details

Model shown may include optional equipment

C-Series C80A/C86A

C80A – Articulated Frame

C86A – Articulated Frame, All-Wheel-Drive



OPERATING WEIGHTS

(C80A)

Total	15,320 lbs.	6 949 kg
Front wheels	5,120 lbs.	2 322 kg
Rear wheels	10,200 lbs.	4 627 kg

(C86A)

Total	15,870 lbs.	7 205 kg
Front wheels	5,420 lbs.	2 481 kg
Rear wheels	10,450 lbs.	4 744 kg

Weights shown include ROPS canopy, all operating fluids and operator.



ENGINE DATA

(C80A)

Make/Model	Cummins 4B3.9
Type	4 cycle, naturally aspirated, diesel
No. of cylinders	In-line 4
Bore & stroke	4.02 in. x 4.72 in. (102 mm x 120 mm)
Displacement	239 cu. in. (3.92 L)
Horsepower	76 @ 2500 RPM (55 kW @ 2500 RPM)

(C86A)

Make/Model	Cummins 4BT3.9
Type	4 cycle, turbocharged, diesel
No. of cylinders	In-line 4
Bore & stroke	4.02 in. x 4.72 in. (102 mm x 120 mm)
Displacement	239 cu. in. (3.92 L)
Horsepower	100 @ 2500 RPM (75 kW @ 2500 RPM)

Engine equipped with a dual element, dry-type air cleaner with evacuator. 12 volt starting and electrical system with 65 amp (780 watt) alternator.

Performance: rated gross horsepower to SAE J1995 standard conditions with water pump, lubricating oil pump and fuel system.

Optionally available on the C80A: 100 HP (75 kW) Cummins 4BT3.9 turbocharged diesel engine.



TRANSMISSION

Type: Heavy-duty hydrostatic
Control: Hand lever
Transmission is "declutched" by brake pedal.
Mechanical neutral lockout with neutral start switch.
Operating pressure: 3000 PSI (20 700 kPa)
Maximum pressure: 5000 PSI (34 500 kPa)
Heavy-duty hydrostatic drive gives complete control to the operator over operating ground speeds. This permits very smooth increases or decreases in operating speeds, essential when fine grading. Easy forward or reverse selection without the need for clutching makes repetitive operation, such as pad work, simpler. Infinitely variable motor control provides faster job-site cycle times.

SPEEDS @ 2500 RPM

Working	0 - 10 mph (0 - 16 km/h)
Roading	0 - 20 mph (0 - 32 km/h)

Foot controlled forward and reverse pedal optionally available.



DIFFERENTIAL FINAL DRIVE

Positive traction differential consists of 4 bevel gears and automatic lock-up. Heavy-duty flanged sleeve construction is supported by tapered roller bearings, allowing fully floating, non-load carrying drive axles. A heavy-duty two-speed gearbox provides work and travel modes as well as a neutral position for towing.

Ground clearance: 10" (254 mm)



TANDEM

Fabricated steel box construction. Proven flanged sleeve mounting to final drive housing. Drive chains sized for long life.

Wall thicknesses – inner & outer: 5/8" (16 mm)
Drive chain pitch: 1.5" (38 mm)
Oscillation: ± 25°



WHEELS & TIRES

Tire size: 15 x 19.5, TL, G2
Ply rating (pr.): 8 pr.
Rim size: 12.25" (311 mm)

Bolt-on, interchangeable on C80A only.
All-weather diamond tread tires available.



BRAKES

Hydrostatic drive provides dynamic braking under normal conditions.

Service Brakes: Foot Operated
Fade resistant, hydraulically actuated disc brakes effective on all four rear wheels. System features dual braking circuits for even braking on both sides of the grader. Includes reserve power assist and operator warning system (visual and audible).

Parking Brakes: Hand Operated
Independent, mechanically actuated disc brakes effective on all four rear wheels. System uses a cable equalizer to assure even engagement pressure on both discs. Includes visual and audible warning system for parking brake on.

All braking systems meet SAE Standard J1473 OCT 90, SAE Recommended Practice J1152 APR 80 and ISO 3450: 1985.



FRONT AXLE

Type: fully welded steel truss, gusseted for torsional strength and rigidity. Replaceable wearplates on each side of truss.

Wheel lean: Hydraulic, 15° R or L
Oscillation: 35° up and down; single oscillation pin with replaceable pin supports.
Ground clearance: 16" (406 mm)



STEERING

Type: Hydraulic power steering
Turning radius (outside front wheel)
– articulated frame: 16'10" (5 131 mm)
– straight frame: 27'10" (8 484 mm)
Operating pressure: 1200 PSI (8 275 kPa)



FRAME

Rear: 12" (305 mm) heavy gauge channel
Front: Box type
Size: 1/2" x 8" x 8"
(13 mm x 203 mm x 203 mm)

Full front and rear frame sections. First user lifetime frame warranty.



ARTICULATION JOINT

Articulation 37° right and left.
Power: 2 hydraulic cylinders mounted with replaceable ball joints with dust shields.
Pin constructed from 4" (102 mm) diameter shaft.
Turns on 4 tapered roller bearings with seals.



CIRCLE ASSEMBLY

Size: 39" (991 mm) outside diameter
Type: Full circle
Lifted by two hydraulic cylinders connected with ball joints at turntable. Trunnion-mounted to frame with bearings and replaceable bushings. Turntable centered with 3 adjustable alignment blocks with removable shims. Replaceable wearplate between circle and drawbar. Circle turn cushion valve optionally available.



CIRCLE DRIVE

Circle rotation: 120° either side
Twin hydraulic cylinder circle drive system uses direct acting hydraulic power permitting moldboard repositioning under full load. Permits moldboard to be repositioned within grader's width for travel.



DRAWBAR

Main bar (solid): 4" (102 mm) square
Cross bar (solid): 1" x 4" (25 mm x 102 mm)
T-bar designed for maximum visibility and support.
Connected with ball and socket, shim adjustable.



MOLDBOARD ASSEMBLY

Size: 5/8" thick x 19" high x 11' long
(16 mm thick x 483 mm high x 3 353 mm long)

Replaceable cutting edges and end bits:
1 @ 6' x 6" x 1/2" (1 829 mm x 152 mm x 13 mm)
1 @ 5' x 6" x 1/2" (1 524 mm x 152 mm x 13 mm)

Cut below ground: 8" (203 mm)
Blade ground clearance: 20" (508 mm)
Blade tilt angle, hydraulically powered: 45°
Blade reach outside front tires:
– moldboard extended: 58" (1 473 mm) right or left
– articulated & extended: 87" (2 210 mm) right or left
Optional side shift cylinder available for increased blade mobility.



CONTROLS

Full hydraulic operation of circle turn, blade lift, front blade, moldboard slide, moldboard tilt, articulation, and wheel lean. Direct acting control levers positioned either side of steering wheel.

Operating pressure 1 700 PSI (11 730 kPa)

Operator can use more than one function at a time. Hydraulic tank contains a temperature gauge and sight glass for fluid level checks.

Instrument panel: temperature gauge; oil pressure gauge; fuel level gauge; volt meter; tachometer; hour meter; ignition key controlled start/stop.



FRONT-MOUNTED BLADE

Size 5/8" thick x 17' high x 7' long
(16 mm thick x 422 mm high x 2 134 mm long)

Blade ground clearance 16" (406 mm)

Replaceable, standard grader cutting edge.



SCARIFIERS

Number 4

Mounted on front blade. Replaceable tips.

Cutting depth 6" (152 mm) below blade

Cutting width 43" (1 092 mm)



CAPACITIES

Fuel tank 39 gallon (148 L)

Hydraulic 30 gallon (114 L)

Coolant 4.5 gallon (17 L)

Tandems (ea.) 18 gallon (68 L)

Final drive 4.5 gallon (17 L)



FILTERS

Transmission 10 micron suction

Hydraulic Suction strainer, return 33 micron

Spin-on type filter for easy servicing.

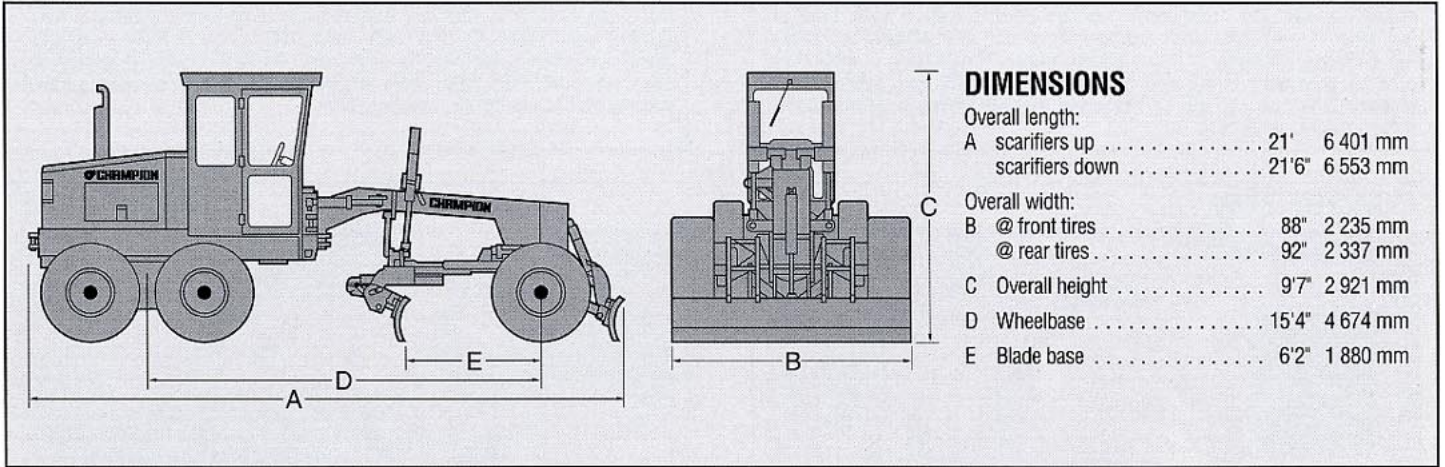

STANDARD EQUIPMENT

- Cummins 4BT3.9 100 HP (75 kW) - C86A
- Cummins 4B3.9 76 HP (55 kW) - C80A
- Hydrostatic drive
- 12 volt electrical system
- Back-up alarm
- Hydraulically Boosted Dual Braking System with reserve power assist
- Ratchet-type park brake with operator warning alarm and indicator
- Gauges: engine temperature and PSI, Volt meter, fuel level, tachometer, hour meter
- Heavy-duty positive traction differential
- 2-speed rear axle gearbox with neutral position
- 11" (3 353 mm) hydraulic sliding moldboard
- Muffler
- 7" (2 133 mm) front-mounted blade
- 4 scarifiers mounted on front blade
- ROPS open canopy
- Seat belt
- Steps and grab handles
- Tilt steering wheel and controls
- Power steering
- Suspension seat
- Hydraulic leaning front wheels
- Lockable engine side panels
- 15 x 19.5 grader tires
- Hydraulic blade pitch adjustment
- Brake and back up lights
- Front and rear directional and hazard lights
- 2 dual beam headlights
- Inside mirrors 6" round convex
- External lockable battery box

OPTIONAL EQUIPMENT

- Front wheel drive (C86A)
- ROPS cab enclosure
- Cab heater
- Windshield defroster
- Beacon light
- Working lights
- Windshield wipers
- Windshield washers
- 13.6 x 16.1, 8 pr., TT, 14" rims, diamond tread all-weather tires
- Air cleaner service indicator
- Mirrors outside
- Cummins 4BT3.9 turbo diesel, 100 HP (75 kW) - C80A
- Rear glass in canopy
- Foot pedal accelerator
- F-N-R foot control pedal
- 5/8" thick x 19" high x 12' long moldboard (16 mm thick x 483 mm high x 3 658 mm long)
- Hydraulic circle sideshift

ATTACHMENTS

- Front-end loader bucket
- Hydraulic broom
- Ripper/scarifier
- Windrow eliminator
- Side dozer
- Automatic blade controls

C86A: ALL-WHEEL-DRIVE

Additional Specifications

AWD operates in low range, speeds from 0 - 10 mph (0 - 16 km/h).

Automatically disengages when the operator presses the brake pedal or shifts the transmission to neutral.

A positive On/Off switch activates the All-Wheel-Drive system in either forward or reverse. This simple control allows the operator to concentrate on the task at hand rather than finding the correct AWD setting. System maintains equalized traction to both front wheels in turns and during low traction situations. Grader retains full front axle mobilities of oscillation and wheel lean.

FRAME



Champion C-Series graders feature a full rear perimeter frame. This provides a strong, stable platform for mounting attachments such as rippers or windrow eliminators. It also provides easy powertrain servicing; either the engine or final drive can be removed independently. The front frame utilizes double-lapped steel through the articulation hinge, arch and highlift, which dramatically increases the sectional strength in these critical areas. The design combination of a full perimeter frame and double-lapping in the high stress areas enables Champion to offer a **first user lifetime frame warranty** on all motor grader models.

CIRCLE, DRAWBAR & MOLDBOARD



All Champion C-Series graders feature a true drawbar, just like a larger-size grader. This provides superior fine grade control and stability when compared to "bulldozer" style blades. The T-shape design provides strength and maximum visibility. Powerful twin hydraulic cylinders position the circle through a 120° arc and can hold and turn it against a fully-loaded moldboard. On the C80A and C86A, power tilt is standard. Moldboard slide is standard on all models. Circle side shift is optional on the C80A and C86A. High circle and moldboard ground clearance make loading and unloading for transport easy.

POWERTRAIN



Since 1984, Champion graders have standardized with Cummins power. The customer gets the benefits of high engine reliability and fuel efficiency. C-Series graders are no exception. The standard powerplant for the C80A is the Cummins 4B3.9 at 76 HP, while the 4BT3.9 turbo at 100 HP is standard in the C86A and optional on the C80A. The transmission is a heavy-duty hydrostatic drive system, making the C-Series ideal for repetitive shuttling operations. A variable speed hydraulic motor reduces job-site cycle times. The final drive contains a two-speed gearbox which permits road speeds up to 20 mph (32.2 km/h). An automatic locking differential divides the power to fully oscillating tandems. Each wheel is driven by chain running in an oil bath.

FRONT AXLE



All the usual front axle mobilities that you expect from a grader are available: axle oscillation, wheel lean and a tight turning radius. These mobilities provide a very agile and versatile grader which is capable of working in confined areas such as parking lots. The large axle box construction, with replaceable pin supports, provides strength, reliability and ease of service that you need. In addition, Champion's C76A and C86A are the only 6-wheel motor graders in this size class to offer the tractive advantage of All-Wheel-Drive. This option improves steering control and productivity on low-traction surfaces. The C-Series All-Wheel-Drive system operates up to 10 mph (16.1 km/h).