

780A

CHAMPION[®] Series IV MOTOR GRADERS



MODEL	780A
Configuration	Articulated
Operating Weight*	45,240 lbs (20 521 kg)
Net hp/kW	200 (150)
* Typically equipped; see specifications for details. Model shown may include optional equipment.	



What it takes to be a Champion

There's a fine line between a good grader and a great one. With the

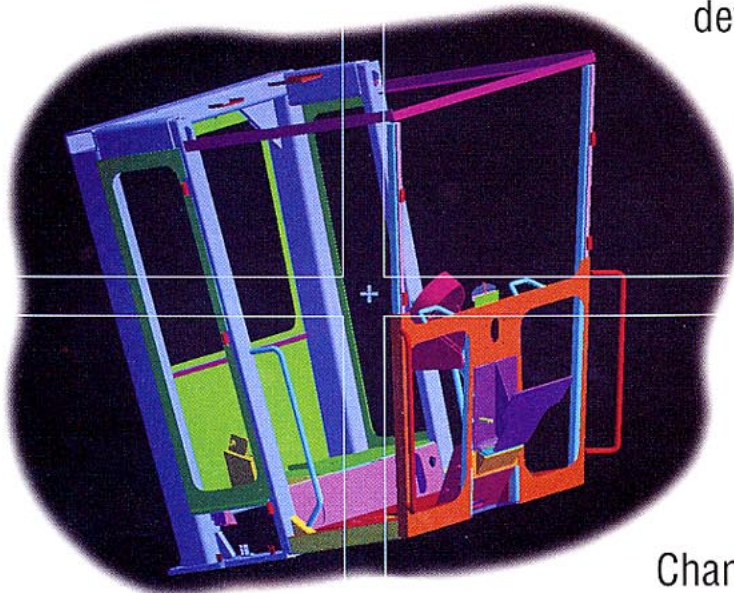

development of Series IV graders,

Champion is crossing that line to be "the best on earth" for every job your grader has to do.

Champion's "voice of the customer" program led directly to many of the operator features introduced in Series IV.

When it comes to cutting new roads and pushing heavy loads, Champion has been the world's number one specialist for a long time.

Now, with Series IV, Champion moves up to first choice for fine grading, too, with a wide-ranging list of new features to enhance productivity. And Series IV also brings you a new standard in reliability engineering so, at the end of the day, you get the job done at a lower cost.

Series IV graders were designed by grader people – we put our engineers into the cab with some of the best operators in the

Series IV is built on a solid foundation of already proven Champion features. Some of these include: the rear perimeter frame, the first user lifetime frame warranty and a hinged rear grill for easy radiator cleaning.

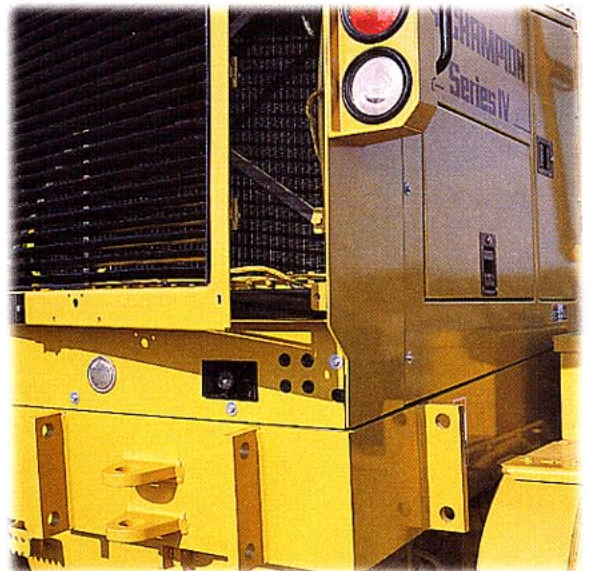

business to compare ideas. We built Series IV together, with over 60 specific design recommendations.

For instance:

- a unique load-sensing hydraulic system for fine grading “featherability” and power to spare
- a clear line-of-sight to the work zone and every area you need to see
- a place to hang your hat
 - a 72° steering arc on the front axle for tighter turns
 - a more comfortable place to work
 - easier access for servicing
- a familiar “operator-friendly” cab layout



... not to mention the rock-solid construction that earned Champion graders a place on the preferred list of fleet owners around the world.

Series IV is getting the kind of support a great Champion deserves, too. Electronic parts ordering. Flexible financing options. Highly trained dealers and service staff. A warranty that says Series IV is built to live up to the name of Champion...

...the best on earth

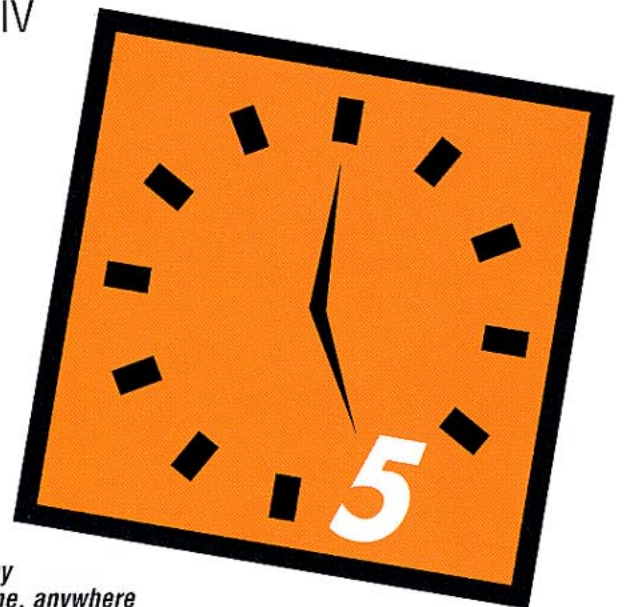

Champion dealers are equipped to support customers with “the best service on earth”, including next-day delivery on emergency parts ordered by 5pm local time, anywhere in the continental United States or Canada.

Looking out for "Number One"

That means you, because the most important part of a grader is the operator who drives it.



When you get into the cab of a Series IV grader, you'll see how every part is engineered to help the operator with the job. The roomy both-feet-on-the-floor layout, adjustable seat and pedal-controlled tilting pedestal let you fit the grader to your personal taste for a comfortable working position.

Make yourself comfortable! Set your feet down, adjust the seat, slide and tilt the pedestal any which-way – all your controls and gauges move with you.

The low-effort clutch and brake pedals and short-throw levers give Series IV a light touch for easy handling and fine precision. The new front window frame, blade lift mounting and front axle all align for an unobstructed line of sight to the work area. The distinctive sloped frame and ergonomic cab design combine for excellent 360° visibility close-in to the cab and wheels. All your operating gauges are up front in clear view, right on the pedestal. From your seat you can see everything you need to do the job – from the controls to the grade stakes, to both ends of the blade, straight ahead and in the curves.

This Champion is built to work as long and hard as you do. Series IV comfort features help an operator get through a full day's grading without tiring. We kept all the hydraulic hoses outside of the cab, so you don't have to worry about leaks or excess heat and noise on the inside.

No matter what grader you have run before, you'll feel at home with the new Series IV lever arrangement and low-effort controls.

The cab's instrumentation is arranged in a logical sequence including the 3-level M4 electronic monitoring system and the side console where your switches are arranged in proper operating order. Everything is backlit for late work.

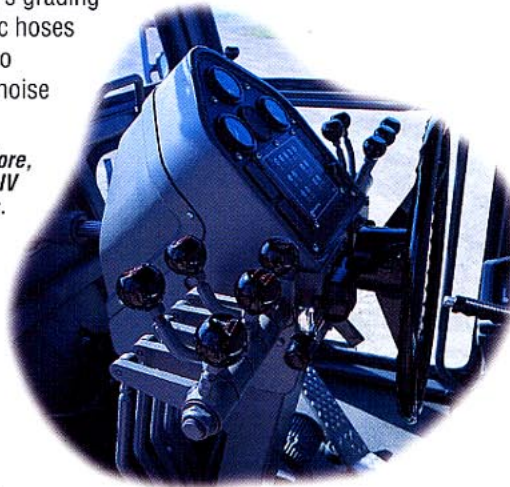

With a busy season ahead of you, little extras can make a big difference. That's why

Champion engineers went to work on a package of thoughtful options for hard-working operators...things like a coat hook in the cab and sliding windows to catch a fresh breeze. We even created a new left-side convenience console, an exclusive Series IV option designed to help you bring some of the comforts of home to work with you.



The whole package makes Series IV a better place to work – a grader that reduces fatigue, speeds up duty cycles and does more for the money.

Series IV options include a new left-side console with operator conveniences including a lunch box cooler, vacuum bottle, ash tray and cup-holder.



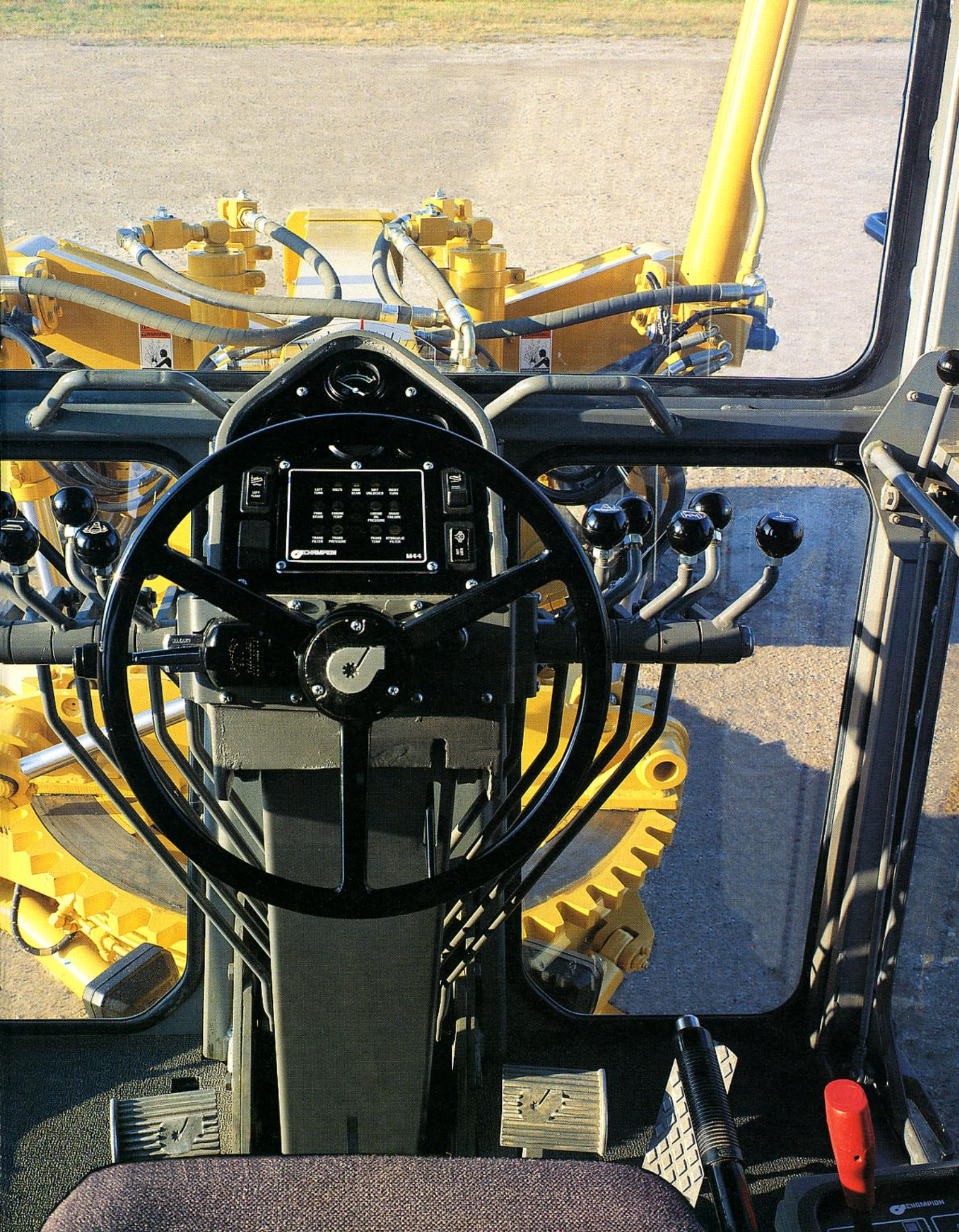

LEFT SIDE METER
RIGHT SIDE METER
ALL WHEELS
HYDRAULIC OIL LEVEL
BRAKE PRESSURE
FUEL PRESSURE
TEMPERATURE
CHALLENGER M44

CHALLENGER

Series IV: 780A

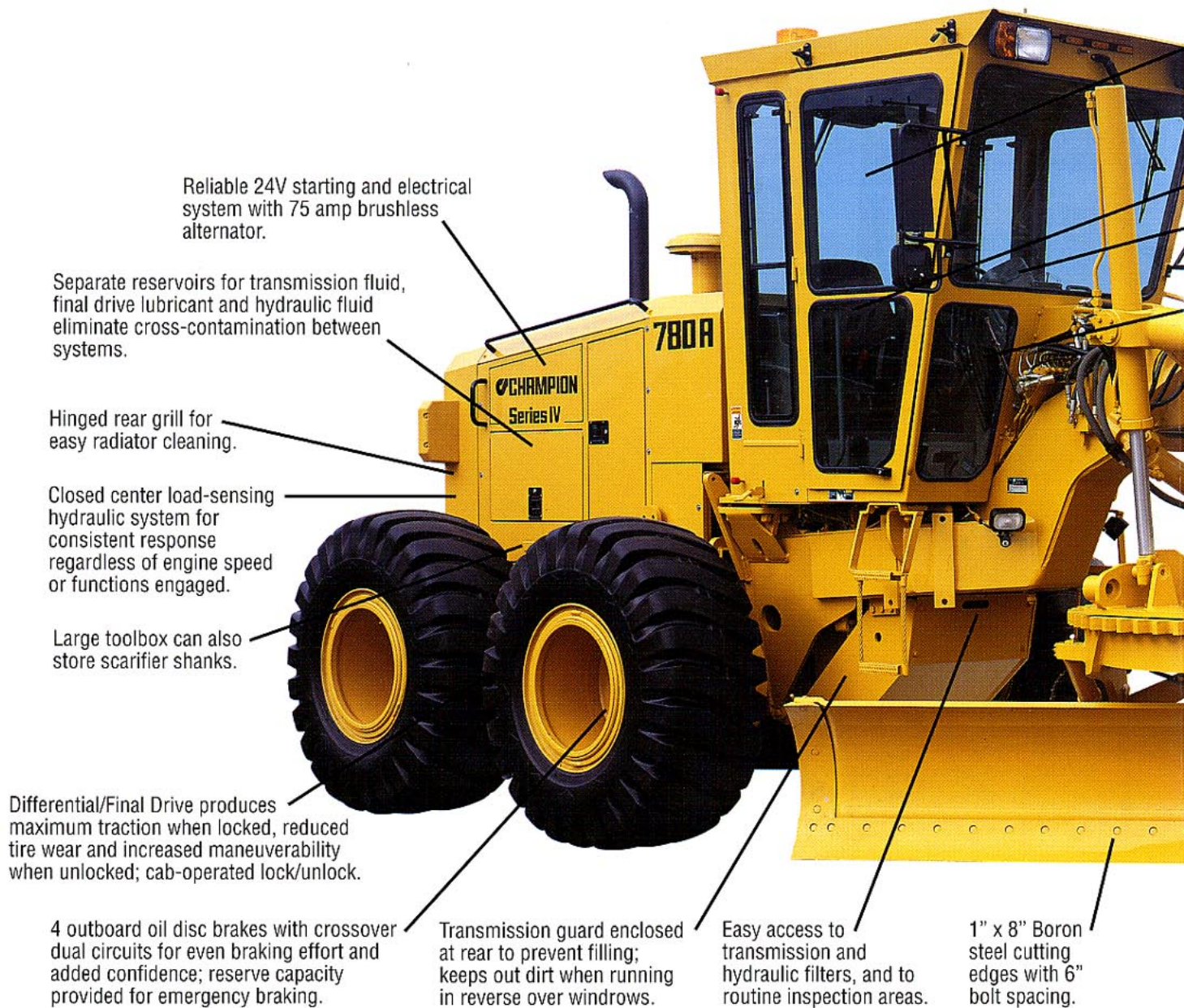

Job-matched dependable Cummins diesel power offers superior fuel efficiency as the engine's peak torque is matched to transmission shift points. Optional side panels are lockable and provide easy access for routine maintenance.



The exclusive **Champion 8400** grader transmission is now in service in more than 10,000 units. Evenly proportioned gear ratios provide precise, job-matched speeds for any grading application. A new "Smart Shift" feature lets the operator easily customize shift patterns to the job at hand.



Series IV cab changes include a "sweep-out" cab floor, easy-to-use door releases and re-enforced door and window frames. Two-piece door glass design makes glass replacement easier and less costly than ever before!



Twin 5 inch diameter hydraulic cylinders articulate the frame 22°. The main hinge pins are 3" in diameter and are contained within sealed housings. Anti-drift lock valves ensure drift-free operation.

Standard cab (shown) is 6'2" (1 880 mm) tall inside;
Low Profile Cab reduces height of grader by 12" (305 mm).

Wide padded arm rests for operator
comfort (on optional suspension seat).

Tilt-head pedestal with
pedal-controlled fore & aft
movement.

Short-throw, low-effort control levers
in industry-accepted spacing and
sequencing.

Double-lapped frame
in high stress areas.

Nose profile permits
exceptional visibility,
especially when fine
grading through curves.

CHAMPION

Heavy duty drawbar
with long blade base
for maximum blade
down pressure.

New front axle with
72° of steering arc.



The 1 1/2" x 4" upper and lower
slide rails are supported on one
piece zinc alloy bearings providing
superior wear life in arduous
applications.

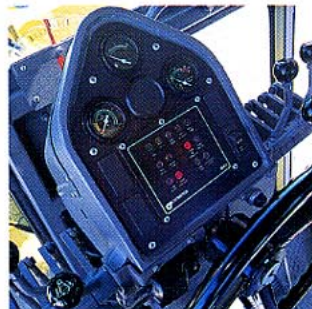

Pedestal includes a 3-level
electronic monitor to alert operator
to machine status, with backlit
switches and fuel level, engine oil
pressure and engine coolant
temperature gauges.

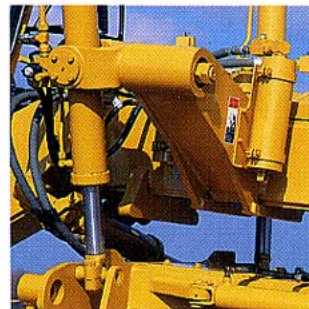

Rugged design of the standard
fixed-point blade lift system
provides fewer moving
components for low maintenance.



Patented dual-cylinder circle drive
uses direct-acting hydraulics for
exceptional turning and holding
power under full load. Circle drive
system is protected against impact
damage by an overload cushion
valve as standard equipment.

Give the job to a Champion

Series IV graders are designed to work better with you... and they're equipped to do more for you!

With their all-new closed center load-sensing hydraulics, Series IV graders achieve a new level of precision and responsiveness for fine grading control. The system senses the load requirement of the hydraulic functions, including steering, and maintains the system pressure 250 psi (17,25 Bar) above the load. When hydraulic power is not required, standby pressure is held at just 90 psi (6,2 Bar), to improve fuel efficiency and reduce heat. Valve spool metering ensures precise blade control, while the variable flow pump maintains consistent hydraulic speed at all engine RPMs and in multiple function operations.

With its 72° front axle steering arc, Series IV moves comfortably in confined work areas. The tight turning radius means faster finishing in cul-de-sacs and less following-up in the corners.

When push comes to shove, there's simply no grader anywhere that gives you more raw strength for cutting into the toughest jobs. Series IV heavy-duty graders match extra power with extra reinforcement where you need it most. The circle takes a wide, powerful stance for performance – it spreads out over 66" in diameter and the top plate is fully 2" thick. Hardened teeth are cut on the outside for maximum leverage and minimum wear. With 5 adjustable clamp plates and 5 adjustable guide shoes, the circle is held firmly in place. This provides even distribution of the load over the entire circle. DURAMIDE™ facings on the clamps and guide shoes eliminate metal-to-metal contact, so the "business end" of your grader spends less time in the shop and more time on the job.

From its heavy-duty front axle to its reinforced tandem case, Series IV is the answer to tough grader applications.





◀ The main hydraulic/steering pump is a load-sensing gear-type pump chosen for extended service life and low replacement cost. Gear type pumps are more tolerant of fluid contamination, perform better in cold weather, and are easier to service than piston pump designs.

High load-carrying capacity is achieved by ▶ supporting the front axle on a 3" diameter oscillation pin; the widely spaced sealed bearings ensure that the load is distributed evenly for long-term durability. Straddle-mounting the twin 4" wheel lean cylinders also evens out the distribution of applied loads; the circuit includes an anti-drift lock valve as standard equipment.

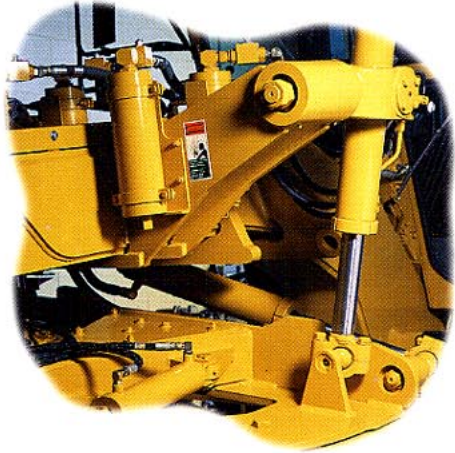
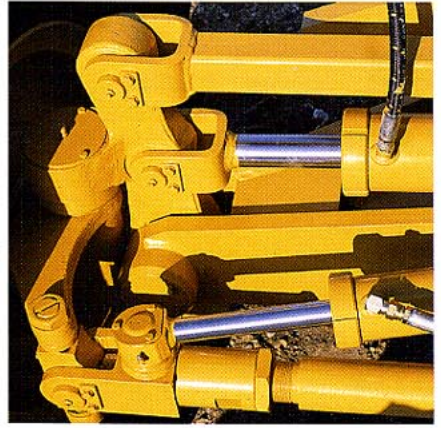

◀ The heavy-duty 2 1/2" piston rods provide maximum strength to Series IV blade lift cylinders for tough applications like mining and forestry. Standard equipment includes nitrogen precharged piston accumulators to absorb impact loads; isolation valves ensure rock-steady blade control in fine grade applications where shock protection is not needed.

With Series IV, the final drive features an ▶ operator-controlled lock/unlock differential. Internal gusseting in the tandem case resists torsional stresses, while the mounting and 1" thick inner wall resists flexing from side loads in severe applications.

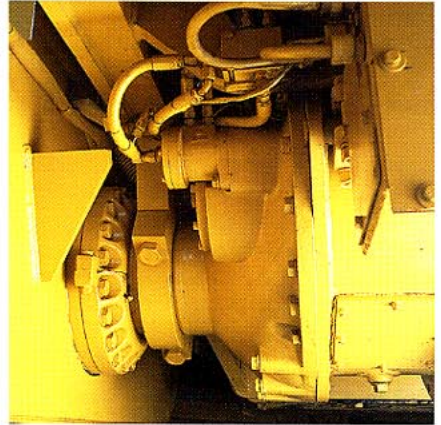

SPECIFICATIONS: 780A



OPERATING WEIGHT (Standard Equipment)

Weights shown include full cab with ROPS, all operating fluids and operator.

Total 40,600 lbs. (18 416 kg)
On front wheels 12,160 lbs. (5 516 kg)
On rear wheels 28,440 lbs. (12 900 kg)

Weight adjustments for various options are listed.

Typically equipped operating weight: Includes 20.5 x 25, 12 pr., L2 tires on 17" (432 mm) rims, and 16' x 31" x 1" (4 877 mm x 787 mm x 25 mm) moldboard.

- with rear-mounted Ripper-Scarifier and 9' (2 743 mm) dozer blade 45,240 lbs. (20 521 kg)



PRODUCTIVITIES (Standard Equipment)

Maximum blade pull (no wheel slip) 25,596 lbs. (11 610 kg)
Blade down pressure
- cutting capability (ISO 7134) 21,521 lbs. (9 639 kg)
- compaction capability 23,189 lbs. (10 519 kg)

Blade down pressure is the maximum downward force which may be applied at the cutting edge.



ENGINE DATA

Make/Model Cummins LT-10-C
Type 4 Cycle, Turbocharged
No. of cylinders In Line 6
Bore & stroke 4.921 x 5.354 in. (125 x 136 mm)
Displacement 611 cu. in. (10 L)
Rated gross brake horsepower @ 2100 RPM 215 hp (160 kW)
Rated net brake horsepower @ 2100 RPM 200 hp (150 kW)
Peak torque @ 1300 RPM 630 lb. ft. (854 Nm)

Engine equipped with a two stage, dual element, dry-type air cleaner with evacuator and dash-mounted service indicator. 24 volt starting and electrical system with 75 amp (1800 watt) brushless alternator with internal voltage regulator. Two heavy duty 12 volt maintenance-free batteries with 900 cold cranking amps (CCA) and 160 minutes reserve capacity per battery. System includes battery disconnect.

Performance: Rated net brake horsepower SAE standard J1349/ISO 3046-2 conditions with water pump, lubricating oil pump, fuel system, air cleaner, muffler, alternator, and cooling fan.



TRANSMISSION

Make/Model Champion 8400
Fully sequential, direct drive, powershift transmission. Engine can not be started if transmission is in gear. Transmission controller contains an electronic self-diagnostic feature. The flywheel-mounted, multi-disc master clutch is oil-cooled for long life.

Ground speeds at 2100 RPM with standard tires:

Forward			Reverse		
Gears	mph	km/h	Gears	mph	km/h
1	2.3	3.7	1	2.3	3.7
2	3.3	5.3			
3	4.5	7.2	2	4.5	7.2
4	6.3	10.1			
5	8.9	14.3	3	8.9	14.3
6	12.5	20.8			
7	17.3	27.8	4	17.3	27.8
8	24.1	38.8			

Heavy duty transmission guard is standard equipment and is hinged for easy access.



DIFFERENTIAL / FINAL DRIVE

Make/Model Champion Twin Bull Gear
Double reduction final drive with an operator controlled lock/unlock differential. Rear axles are case hardened, full floating design, supported on double row spherical roller bearings.



TANDEM

Oil-tight, oscillating tandem case has internal gusseting for maximum torsional strength. Field proven split ring/flanged sleeve tandem mounting and 1" thick inner wall resists flexing from side loading during severe applications. Drive chain sized for long life.

Depth 24.5" (622 mm)
Width 8.25" (210 mm)
Thickness - inner wall 1.0" (25 mm)
- outer wall 0.75" (19 mm)
Center distance 65.5" (1 657 mm)
Drive chain pitch 2.0" (51 mm)
Oscillation ±15°



BRAKES

Service Brakes: Foot Operated

Fade resistant, hydraulically actuated, oil disc service brakes located at the four (4) tandem drive wheels are self-adjusting, fully sealed and maintenance-free. System features cross-over dual braking circuits for even braking on both sides of the grader. Includes reserve power assist and operator warning system (visual and audible).

Parking Brake: Hand Operated

Independent, disc-type hand brake on transmission output shaft and effective on all four (4) tandem drive wheels. Includes visual and audible operator warning system for parking brake on, transmission in gear condition.

Braking systems to: SAE Recommended Practice J1473 OCT. 90, and J1152 APR. 80; ISO 3450-1993-01-28. Champion uses asbestos-free brake components.



WHEELS & TIRES (Standard Equipment)

Tire size 16.00 x 24, G-2
Ply rating (pr.) 12
Rim size 10.0" (254 mm)
Bolt-on rims are interchangeable front and rear.



FRONT AXLE

Type ... Fully welded steel truss, gusseted for torsional strength oscillates on a single 3" (76 mm) diameter centre pivot pin
Wheel lean 18° R & L
Oscillation 16° up and down
Ground clearance 27.5" (698 mm)
Twin 4" (102 mm) diameter wheel lean cylinders with lock valve is standard equipment.



STEERING

Hydraulic power front wheel steering incorporating two steering cylinders. Full power assist supplemental steering, meets SAE J53 OCT. 84.

Minimum turning radius using front axle steering, wheel lean and unlocked differential:

..... 25'5" (7 747 mm)
Steering arc 72°
Frame articulation angle 22°
Articulation lock standard.



FRAME

Full front and rear frame sections. First user lifetime frame warranty.

Front: Fully welded box section. Double-lapped in high load areas. Lowered nose plate on front frame provides the best visibility in the industry to the front of the grader.

Minimum dimensions of box section 10.0" x 12.0" (254 mm x 305 mm)
Plate thickness 3.0" & 0.75" (76 mm & 19 mm)

Vertical section modulus (min.-max.) 166-293 cu.in. (2 720-4 801 cm³)

Linear weight (min.-max.) 132-288 lbs/ft (196-429 kg/m)

Rear: Full rear frame permits modular powertrain mounting for ease of service and simplifies attachment mounting.

Minimum dimensions of rear frame 4.0" x 11.0" (102 mm x 279 mm)
Plate thickness 3.0" & 0.75" (76 mm & 19 mm)

Articulates behind cab. Twin 5" (127 mm) hydraulic cylinders articulate frame 22° right and left. Anti-drift lock valve ensures stable operation.



CIRCLE

Hardened teeth, cut on outside of circle for maximum leverage and minimum wear. Circle is machined after welding to ensure flatness. The circle is held positively in place

at 10 points by five adjustable clamp plates and five adjustable guide shoes providing optimum circle support and load distribution. The primary set of clamps and guide shoes is located at the front of the circle where greatest loading occurs. DURAMIDE-faced clamp and guide shoes prevent metal to metal contact. DURAMIDE is a synthetic material that extends service life and reduces maintenance requirements.

Diameter66.62" (1 692 mm)
 Thickness2.0" (51 mm)
 Adjustable guide shoes 5
 Adjustable clamp plates 5



CIRCLE DRIVE

Champion's patented dual cylinder circle drive system uses direct-acting hydraulic power for exceptional turning and holding capability under full load. Circle drive system is fully protected against impact damage by an overload cushion valve as standard equipment.

Hydraulic drive cylinders 2
 Points of leverage 2
 Rotation 360° continuous



DRAWBAR

Fully welded box section. Narrow 'T' design permits optimum visibility to the work area. Drawbar connection provides an adjustment to compensate for different tire sizes. Blade lift cylinder anchors are straddle-mounted on drawbar to provide maximum strength and support.

Dimensions of box section 6.5" x 6.5"
 (165 mm x 165 mm)
 Plate thickness 1.5" & 0.75"
 (38 mm & 19 mm)



MOLDBOARD

Standard moldboard with replaceable end bits 14' x 31" x 1"
 (4 267 mm x 787 mm x 25 mm)
 Blade material ... SAE 1050 high carbon steel
 Edge: through hardened 8" x 1"
 (203 mm x 25 mm) boron steel
 Drilling - 6" ... Bolt diameter - 3/4"
 Slide rails supported with adjustable Za12 (Zinc aluminum) bearings for maximum wear resistance.

BLADE RANGE: FIXED POINT LIFT SYSTEM (Standard)

(Dimensions shown with standard moldboard)
 Reach outside tires
 - articulated frame 138.0" (3 505 mm)
 Blade slide 53.5" (1 359 mm)
 Circle side shift 17.5" (445 mm)
 Blade ground clearance 18.5" (470 mm)
 Blade cutting depth 25.0" (635 mm)
 Blade tilt range46° forward; 13° back
 Number of moldboard tilt cylinders 2
 Bank sloping angle 90°



CAB & CONTROLS

Operator noise exposure is limited to 82 dB(A) per SAE J919 JUNE 86 (enclosed cab). Located in the pedestal head is the engine oil pressure, coolant temperature and

fuel level gauges and a three-level electronic monitoring system. Pedestal located switches include: differential lock/unlock, independent moldboard floats (optional) and combination turn signal, hazard lights, and high beam headlight switch. Heater and wiper/washer controls, lighting and accessory switches are grouped in the operator's right hand console. This console also contains the ignition key and access to the circuit breaker panel. An accelerator/decelerator foot pedal and slider type hand throttle are standard equipment. Cab door opening and closing is easy from either a seated position or while entering and exiting. Fixed front window enhances visibility by reducing window frame width.

Full Height Cab with ROPS INSIDE DIMENSIONS:

Height..... 74.0" (1 880 mm)
 Width @ controls 56.0" (1 422 mm)
 Depth @ controls 55.5" (1 410 mm)

An optional Low Profile Cab is available with an inside height of 62" (1 575 mm). All Champion cabs and canopies are designed to meet or exceed SAE J1040 APR. 88, ISO 3471/1-1986(E), and 86/295/EEC ROPS requirements. The seat belt is 3" (76 mm) wide and meets SAE J386 JUNE 93; ISO 6683-1981(E). A cushioned vinyl covered bucket seat with fore & aft and height adjustment is standard.



LOAD SENSING HYDRAULICS

Closed center hydraulic system senses load requirements and maintains system pressure 250 psi (17,25 Bar) above the load.

When hydraulic pressure is not required, system pressure is only 90 psi (6,2 Bar). Low standby pressure improves fuel-efficiency and reduces heat generation.

System incorporates lock valves to prevent cylinder drift under load in the following circuits: blade lift, moldboard tilt, circle shift, wheel lean, articulation and scarifier. All hoses and fittings are equipped with 'O' ring seals to eliminate leaks.

Pump design features include cast iron end covers and center housing, and a one-piece gear and shaft assembly to ensure reliability and a service life exceeding that of most piston pumps.

Maximum pressure 2,500 psi (172 Bar)
 Output at 2100 RPM 0-48.2 gpm
 (0-182 lpm)
 Filtration 7 micron spin-on type



CAPACITIES

	U.S. Gal.	Imp. Gal.	Litres
Fuel Tank.....	100.0	83.3	378,5
Transmission	10.2	8.5	38,8
Final drive	9.0	7.5	34,0
Tandems (ea.).....	27.7	23.1	105,0
Hydraulic oil tank	23.8	19.8	90,0
Coolant Antifreeze protection to -58° F (-50° C).....	10.8	9.0	40,8
Engine oil.....	10.3	8.6	39,0

STANDARD FEATURES:

- Operator controlled, lock/unlock differential final drive
- 4-wheel, cross-over, dual braking system with reserve power assist
- Ratchet-type park brake with operator warning alarm and indicator
- Fully-sequential, powershift 8400 transmission, with guard
- 13.5" diameter, 4-plate, full oil clutch for operator control
- Full front and rear frame sections designed to absorb shock loading of attachment use
- First user lifetime frame warranty
- Cushion valve circle drive protection to minimize impact damage
- Hardened circle teeth cut on outside of circle for maximum wear resistance
- Isolation-mounted cab, transmission and engine for reduced noise and vibration
- Adjustable steering pedestal with tilt head for maximum operator comfort
- Gauges include: coolant temperature, engine oil pressure, fuel, hourmeter, dash-mounted air cleaner service indicator, articulation angle indicator, three-level electronic monitoring system - M4 - with visual and audible warnings
- Load-sensing, closed-center hydraulic system with short-throw, low effort control levers, positioned in the industry-accepted arrangement. Hydraulically operated blade lift, circle turn, moldboard slide and tilt, circle shift and wheel lean functions.
- 100 gallon fuel capacity
- Horn
- Hinged radiator guard for easy trash clean out. Engine compartment fan guard included.
- Back-up alarm with automatic volume level
- Painted Champion Yellow
- Lockable tool box with storage space for scarifier shanks

OPTIONAL EQUIPMENT (May vary)

	lbs.	kg
Air conditioner - 21,500 BTU - HFC-134a (non-CFC refrigerant) with cab pressurizer/filter	130	59
Battery warmer	5	2
Brush guards	40	18
Cab - canopy shell with ROPS - deduct	(200)	(91)
- low profile cab with ROPS - deduct	(200)	(91)
Cab heater - 49,000 BTU.....	30	14
Cab pressurizer/filter	14	6
Defroster fan	3	1
Engine block heater.....	3	1
Engine precleaner - Turbo II	6	3
Engine side panels	50	23
Ether cold start	10	4

OPTIONAL EQUIPMENT (cont'd)		lbs.	kg			lbs.	kg			lbs.	kg
Exhaust rain cap	-	-	-	Machine Monitor Plus package - M44	Remote valve for attachments	-	-	- 3 or 5 bank - remote mount	25	11	
Fan - blower type (suction type is standard)	-	-	-	Audible and visual warnings for transmission and hydraulic filter restriction, low engine oil pressure, high coolant temperature, high transmission temperature, and low transmission clutch pressure	-	-	-	Suspension seat	55	25	
Float control - Right and Left independent, electric	15	7		Mirrors - outside - right	2	1		Tie-down brackets	100	45	
Hub odometer	-	-		- left	2	1		Tires			
Hydraulic tank heater	3	1		Moldboards				- 20.5 x 25, 12 pr., TL, L2 or L3, 17" (432 mm) rims	590	268	
Jack - 20 ton (18.5 tonne)	35	16		- 16' x 31" x 1" (4 877 mm x 787 mm x 25 mm)	300	136		Tire chains - pair	300	136	
Lights				Moldboard extensions R & L				Tool kit	-	-	
- back-up lights - 2	-	-		- 2' (610 mm)	200	91		Transmission sump heater	-	-	
- beacon (amber or blue)	4	2		Moldboard edges -Carbide 3/4" x 5" ..	-	-		Tropical protection	-	-	
- clearance lights front & rear	2	1		Operator convenience package				Vandalism protection	8	4	
- direction signals	-	-		- lunch box, steel vacuum bottle and holder, ash tray	10	5		Wheel weights front or rear			
- front-mounted plow lights - 2				Paint - custom colors	-	-		- each	250	113	
- high	120	54		Radiator shutters - hinged	10	4		Window -opening - lower front	-	-	
- low	100	45		Reflectors - rear	-	-		Window - opening sliders - left/right	-	-	
- Headlights with dimmer switch	-	-						Wiper and washer - front	-	-	
- Moldboard lights - 2	2	1						Wiper and washer - rear	-	-	
- Rear flood lights - 2	2	1						Wiper and washer - lower front windows	-	-	
- Snow wing lights - 2	2	1									

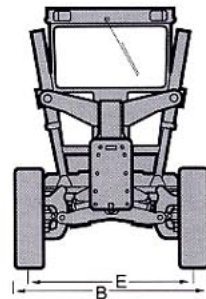
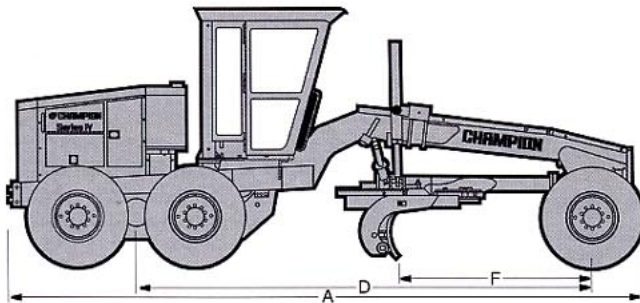

DIMENSIONS

A Overall length	28'6" (8 687 mm)
B Overall width	9'2" (2 794 mm)
C Overall height with cab	11'6" (3 505 mm)
- with Low Profile Cab	10'6" (3 200 mm)
D Wheelbase	20'6" (6 248 mm)
E Tread width	7'7" (2 311 mm)
F Blade base	
- ISO 7134	8'11" (2 718 mm)
- compaction	9'9" (2 972 mm)

CHAMPION MATCHED ATTACHMENTS

A-Frame	850 lbs. (386 kg)
Dozer blade	
- 8' (2 438 mm)	1,600 lbs. (726 kg)
- 9' (2 743 mm)	1,650 lbs. (749 kg)

One-way plow	2,350 lbs. (1 067 kg)
Push block	700 lbs. (318 kg)
Ripper-scarifier, rear	2,100 lbs. (953 kg)
Snow wing	
- rear-mounted	3,100 lbs. (1 407 kg)

V plow	
- 9' (2 743 mm)	2,560 lbs. (1 161 kg)
- 10' (3 048 mm)	2,720 lbs. (1 234 kg)
Windrow eliminator	1,300 lbs. (590 kg)

Specifications subject to change without notice. Some items included in this brochure are optional.
TM DURAMIDE is a registered trademark of Champion Road Machinery Limited.
 Your safety and the safety of those around you depends on using care and judgement when operating
 and servicing your grader. Do not operate the grader until you read and understand the warnings and
 instructions in the operator's manual.



CANADA
 Goderich, Ont.

© 1994 Champion Road Machinery Limited