

**VOLVO ARTICULATED HAULERS**  
**A35E, A40E**



**MORE CARE. BUILT IN.**



# TRUST ISN'T GIVEN, IT'S EARNED

It's no surprise that every other articulated hauler manufactured in the world today is a Volvo. It was Volvo that developed the hauler concept in the 1960s and since then, we've been the development leader. With the E-series, we reinforce our position as the world's leading manufacturer of articulated haulers. When you choose the A35E and A40E, you know you'll get the job done – quickly, smoothly, cost-effectively, and safely.

## Advantage Volvo

As the world's biggest and leading manufacturer of engines for heavy equipment, Volvo has an unbeatable advantage. With in-house developed drivetrains – designed for the tough demands on articulated haulers – the A35E and A40E have the strength and durability needed for maximal productivity.

## Trouble-free ownership

Choosing an articulated hauler from Volvo gives you both a machine and a partner you can trust. Volvo A35E and Volvo A40E are two of the most reliable machines on the market. Volvo Construction Equipment's global dealer network and well-trained service technicians means always having a dedicated partner near yourself and your operation. This means peace-of-mind ownership, and you always have a machine that gives higher profitability and productivity.

Specifications	A35E		A40E	
Engine, Volvo	D12D AEE3*/AFE3**		D16E AAE3*/ABE3**	
Max power at	30 r/s	1 800 r/min	30 r/s	1 800 r/min
SAE J1995 Gross	313 kW	419 hp	350 kW	469 hp
ISO 9249, SAE J1349	309 kW	414 hp	346 kW	464 hp
Max torque at	20 r/s	1 200 r/min	20 r/s	1 200 r/min
SAE J1995 Gross	2 100 Nm	1 549 lb ft	2 525 Nm	1 862 lb ft
ISO 9249, SAE J1349	2 056 Nm	1 547 lb ft	2 493 Nm	1 837 lb ft
Max. Speed	57 km/h	35.4 mph	57 km/h	35.4 mph
Load Capacity	33 500kg	37 sh tn	39 000 kg	43 sh tn
SAE 2:1 heap	20,5 m <sup>3</sup>	26.8 yd <sup>3</sup>	24,0 m <sup>3</sup>	31.4 yd <sup>3</sup>
Net weight	28 100 kg	61 950 lb	30 200 kg	66 580 lb
Gross weight	61 600 kg	136 686 lb	69 200 kg	152 560 lb

\*) Meets US (EPA) Tier 3, California (CARB) Tier 3 and Europe (EU) Stage III.

\*\*) Meets Europe (EU) Stage IIIA





# FEEL AT EASE, EVEN ON EXTREME WORK SITES

It's when the going gets tough and demands are stepped up that you really see the great benefits of Volvo's articulated haulers. Simply put, they are built to effectively haul different types of loads in the most extreme conditions, without taking the long way around. When other hauling solutions bog down and stop working – due to climate, ground conditions, and high demands on availability – our haulers continue to get the job done quickly, safely, and effectively.

## **Always the shortest route**

Where rigid haulers and trucks have to take the long way around or risk getting stuck, that's where Volvo's articulated haulers operate smoothly and safely, taking the shortest route between loading and dumping sites.

The unique maneuverability is due to the rotating hitch and the frame steering, making it possible for the tractor and trailer to move independently of each other. This reduces stresses on the frame in off-road operations and makes the machine easy to operate – even with a full load – since all the wheels have good ground contact.

## **Wide-ranging, high-reliability hauler**

Throughout the years, the Volvo hauler concept has proven to be perfect for different types of earth-moving at major construction projects, such as road and dam construction. But the articulated hauler is also the optimal solution in many other applications, such as operations in sand and gravel pits, quarries, mines, tunnel construction, and on landfill sites, just to mention a few examples.

The common feature of all these work sites is that they often have demanding loading and dumping sites, large volumes have to be hauled, and often the work area has no roads – but still the vehicles must have the ability to maintain high speeds where there are roads.



## **Volvo Experience**

Volvo invented the articulated hauler. The first production machine was in 1966 and the concept has been refined over 40 years of experience

## **Volvo Reliability**

Volvo Articulated Haulers are proven in different operating conditions to increase profitability and lower operating costs





# BOOST YOUR BUSINESS GROWTH

Maximum productivity at the lowest possible cost is the best way to become profitable. With the A35E and A40E, it's possible to actually do it. The heart of the machine – the drivetrain – is developed by Volvo, down to the smallest detail. That's natural to Volvo since the drivetrain – engine, transmission, dropbox, axles, and wheels – is decisive for the machine's rimpull, operating reliability, fuel consumption, and service life. To that you can add minimal service needs, and you can confidently count on profitability in the long run.

## **The new generation's engines**

Volvo's new engines give A35E and A40E both more power and rimpull. The D12 and D16 engines feature Volvo Advanced Combustion Technology and get maximal energy from every drop of fuel. The turbocharged, low-emission diesel engines feature electronically-controlled direct-injection and intercooler.

## **Maximum rimpull with Powertronic**

The proven and further developed Powertronic, Volvo's automatic transmission, has given A35E and A40E even higher performance. Powertronic shifts smoothly at exactly the right time, giving high rimpull at all speeds. Shafts, planetary gears, and bearings are reinforced to handle higher torque, making the new transmission a perfect match for the new larger engines. New intelligent electronics allow for better and faster gearshifting, with the possibility of skipping gears in order to negotiate uphill and downhill grades. The refined transmission provides more comfort and highest possible rimpull.

## **Minimum power losses**

Volvo's in-line dropbox has less moving parts than a traditional dropbox, which means minimal power loss. The design enables high placement of the rear output shaft, giving high ground clearance, a high mounted hitch, and improved stability.

## **No daily service**

There's no daily service needed for Volvo's haulers. Monitored checks of oil and fluid levels all add up to minimal service needs. Long intervals between every service mean more time for productive work.

Downtime during service is short, thanks to few service points and simple work. All filters are easy to access, the engine hood opens a full 90 degrees, and the swing-down front grill makes it easy to reach service points on the engine.

CareTrack provides remote monitoring of the machine's position, utilization and performance. With immediate availability of correct facts about your machines, you can analyze the situation shift by shift, and make decisions that result in higher productivity and shorter downtime.

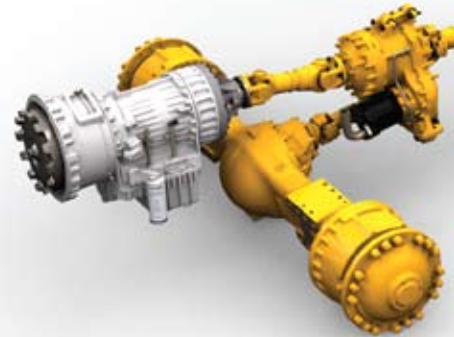

## **Volvo D12 and D16 V-ACT Engine**

Volvo's engines feature Volvo Advanced Combustion Technology, V-ACT, an emission-controlling solution based on simple yet proven technology.

Volvo's in-house engineered and manufactured engines provide for higher power at low rpm for maximum fuel efficiency.

Volvo D12 and D16 engines meet all existing emission requirements according to Stage IIIA/Tier 3.

## **Volvo Heavy-Duty Transmission**

Volvo planetary transmission features smooth shifting providing maximum rimpull at speeds.

Shafts, planetary gears and bearings are reinforced to handle higher torque.

Intelligent and fast gear shifting with gear skipping technology allows for proper rimpull when negotiating inclines and declines.

## **Maintenance and uptime**

Electronic monitoring of fluid levels minimizes service needs and enhances reliability.

No daily service means more time for productive work.

## **Profitable flexibility**

On good haul roads, the operator can choose 6x4-drive, to save tires and fuel – only Volvo haulers offer this choice. In rough off-road operation, the operator can choose 6x6-drive and 100 % differential locks on one or all axles.



# STAY IN COMMAND

Operators can work effectively at a fast pace in the Volvo A35E and Volvo A40E, without getting tired and losing concentration. Several important features make the machine and operator a highly productive unit: the unique brake system, the effective retardation system, the powerful and exact dumping system, and the superior steering system.

## Effective brakes

Both A35E and A40E feature oil-cooled wet disc brakes as standard, giving excellent and maintenance-free braking performance.

## High-performance retardation system

The foot-operated retardation system is user-friendly, effective, and safe since the operator never has to let go of the steering wheel. The hydraulic retardation system is connected to the powerful wet disc brakes. The operator can maintain higher average speeds throughout the whole work cycle thanks to the retarder's fast response, high continuous availability, and high performance.

## Fast and safe dumping

A fully loaded body is raised in only 12 seconds, and lowered in only 10 seconds – with ease and control. The explanation to the short dumping times is Volvo's single

stage, double-acting hoist cylinders.

The effective dumping system makes it possible to place the load in exactly the right position, even on downhill grades.

Volvo's unique and user-friendly Load and Dump brake makes it possible to both increase productivity and decrease operating costs. With the simple push of a button, the transmission shifts to neutral and the trailer service brakes are activated.

## Unique steering system

Volvo's hydro-mechanical and self-compensating steering system is the market's best by far. It gives a unique feel for the road, only comparable to that steady automotive-type feel. Steering angle always remains the same for a given steering wheel position, making it easy to stay on course. This makes Volvo's steering system superior to all other systems on the market, and gives the operator an outstanding control of the machine. Steering is stable at high speeds and powerful in rough off-road conditions – quite simply, a safe machine that's easy to operate.



## Engine retarder for higher speed

Volvo's engine retarder is fast and safe and let the operator maintain higher average speeds.

Foot operated switch allows for safe actuation of engine retarding system.

## Unique Load & Dump brake

A simple push of a button sets the transmission in neutral and all trailer brakes are activated.

## Dumping downhill

Volvo's double-acting, single-stage hoist cylinders have the performance needed to raise and lower the body on downhill grades.

## Dump lever with built-in safety

Dumping and lowering of the body is controlled with the pilot-operated 4-position dump lever. The lever automatically goes to hold position when the operator leaves the seat.

## Optional equipment

It's possible to adapt the body to all kinds of different materials, for example, with tailgates, body extensions, body heating, and spill guard.

## Volvo's unique self-compensating hydro-mechanical steering

Powerful and accurate steering for safe operation and high productivity.





# PROTECT THE CORE OF YOUR BUSINESS

Comfortable operators are productive operators; maximize your profits by keeping your operator comfortable.

Volvo has been the leader for a long time when it comes to operator environment, and our development work with operator's cabs has received several awards. With the E-series, Volvo manifests its position as the leader. Operators in Volvo haulers can stay focused on the job, even on those really long shifts.

## Space and comfort

Our articulated haulers feature the quiet, clean and spacious Volvo Care Cab. The first thing you notice is how easy it is to get in to the A35E and A40E. The steps are well-matched, the door opening is wide and without a threshold. Inside the cab there's plenty of room for the operator as well as other items, such as boots and a lunchbox.

The ergonomically designed operator's seat features air-suspension and is easily adjustable for true comfort. The steering wheel angle can be adjusted, and there's also a vertical height adjustment.

## Focus on visibility

Good visibility all around the machine is an absolute condition for both high safety and high productivity. The operator sits up high in the centrally located operator's seat.

## Maximal enjoyment

Sound level is comfortably low, and Volvo's proven front suspension ensures that the operator is not jolted by ruts and bumps. The unique filtration system in the Volvo Care Cab provides a clean cab environment in a class of its own. The effective air-conditioning system makes sure that the cab temperature always keeps the operator comfortable.



## Volvo Care Cab

Volvo's world class operator's environment features a larger, more spacious interior and large storage compartments.

The Volvo Care Cab pressurizes and filters all incoming air twice, promoting a clean interior and a healthy, happy operator.

Contronic Monitoring System alerts the operator of machine status and maintenance needs, providing maximum availability and protection during the shift.

Good visibility, from the wide windshield to the well placed rearview mirrors, allows for safe and productive work.



# ADVANTAGES THROUGH INNOVATIONS

Volvo has developed several systems that help you make the right decisions and use your machine with optimal effectiveness. CareTrack gives you information on your machine right in your computer, regardless of where it is. Contronic makes sure that the operator has information about the machine's vital functions in real-time, and Matris is an effective analysis tool which gives solid advice on how the machine can be operated more efficiently.

Volvo's global dealer network ensures that you're never far from genuine Volvo spare parts and specially trained service technicians who know your specific machine.

## Always on the right track

CareTrack is a telematic system developed to work with the Volvo machine's own diagnostics system. On a password-protected website, you can "see" the exact location of your machine, what the fuel consumption looks like, and when it's time for next service. With immediate availability of correct facts about your machines, you can analyze the situation shift by shift, and make decisions that result in higher productivity and shorter downtime. CareTrack is also excellent theft-protection, since you can use your computer to "lock in" the machine in a specified geographic area.

## Real-time information

The built-in Contronic monitoring system enables the operator to always keep an eye on the machine's functions in real-time. The information display on the control panel gives continuous updates on the machine's functions, including outdoor temperature, fuel consumption, and fluid level.

## Matris has the answers

Matris is a PC-based follow-up system which, when connected to the machine, measures and analyzes how the machine has been used. The operating history gives clear information in tables, circle or bar diagrams, on, for example,

use of the engine, brakes, and transmission, as well as fuel consumption.

## A safe choice

Service and maintenance is the starting point in making your machine investment just as profitable as you want it to be. The key is to let your Volvo remain a Volvo. With genuine Volvo Parts you know that the machine's built-in values – such as operating reliability, performance, safety, and comfort – will endure, year after year.

## Tailored to your needs

- The Volvo Articulated Hauler can be personalized in many ways to meet your specific operating needs based on conditions and applications.
- To adapt the machine further it offers a number of software parameters that can be set based on customer input.
- Machine software parameters can be set (adjusted) to enhance machine functionality, meeting your specific jobsite environments and demands.
- Service agreement or repair contract can boost your competitiveness and make your operation more profitable.

Contact your local dealer for further information.



## CareTrack\* advanced telematics

GPS positioning, mapping, Geo- & Time-fence functions monitor your machine fleet.

GPRS and/or Satellite transfer of operating data, error codes\*\*, logged machine data\*\*.

Service reminders and alarms, including forwarding by E-mail and text message.

Machine utilization, including fuel consumption.

\*) Optional equipment

\*\*\*) Available with CareTrack Advanced

## Contronic monitoring system

Overriding computerized electronic monitoring system, dependable and easy to use.

Coordination of reliable engine and machine computers for optimum performance and safety.

Display information in three categories – current operating data, warning texts and error messages.

Monitors fuel consumption, cycle times and service intervals.

The system has built-in safety functions that automatically limit the engine's torque and power output in case of major malfunctions in order to protect the engine and transmission, thus reducing the risk of subsequent damage.



# A MACHINE YOU CAN ALWAYS TRUST

## **Volvo's Unique Self-compensating Hydro-mechanical Steering**

- Powerful and accurate steering for safe operation and high productivity.

## **Excellent Operator Environment**

- A spacious and comfortable cab with centrally positioned operator contributes to high productivity throughout the shift.
- Ergonomically positioned controls, air-conditioning, air suspension seat with tilt/telescopic steering wheel, wide angle forward view for reduced operator fatigue and high safety.

## **Volvo Drive Train**

- Correctly matched Volvo-designed components, specifically developed for hauler applications. Low power losses and long service life.
- 9-speed transmission gives smooth shifting and high power at all times.

## **6x4 and 6x6 with Five Operating Modes**

- Easy to use drive combinations for every type of operating condition, reduces fuel consumption, driveline and tire wear and increases off-road mobility.

## **Exhaust Brake and Retarder**

- Easy to operate powerful retardation in combination with wet-disc brakes reduces wear and operating cost.

## **Heavy-Duty Axles**

- Purpose built with 100% dog clutch type diff-lock.

## **High-Capacity Cooling System**

- Power and fuel saving, hydraulically driven, side mounted variable speed fan consumes power only when needed.



#### **Purpose-built dropbox**

- Proven in-line drop-box provides excellent ground clearance, gives stability and low internal power losses.

#### **Swing Down Front Service Platform**

- Grouped engine filters and remote mounted drains reduce service time. Contronic System electronically monitors fluid levels and systems for ease of service and troubleshooting.

#### **Serviceability**

- No daily or weekly service.

#### **Maintenance Free Suspensions**

- The straddle mounted bogie beam gives large wheel movement and low frame stress. Low pivot point enhances stability.
- Front axle has independent wheel movement via a 3-point mounting system.

#### **Frames and Chassis**

- Box type design frames provides strong, weight optimized, high quality frames for long service life
- Rotating hitch and articulated steering provides good off-road mobility and less stress on the frames in tough applications. High positioned hitch provides high ground clearance and stability.

#### **High strength steel 400 HB body**

- High chute and tipping joint with 70° or greater dump angle promotes load retention and ejection.

#### **State-of-the-Art Hydraulic System**

- Variable displacement piston pumps consume power only as required.



# IN HARMONY WITH THE ENVIRONMENT

Volvo's machines are built for minimal environmental impact. Caring for the environment is a natural extension of our dedication to giving maximal protection to operators and the environment. We are also convinced that highly developed environmental thinking gives both peace of mind as well as competitive advantages.

## **Use every drop of fuel**

Volvo's V-ACT-engines are designed using an advanced method of fuel injection under higher pressure, a further development of the system for electronic engine control, as well as a smart system for internal exhaust gas recirculation. In short, it means that the exhaust valve opens slightly during the inlet stroke and lets a small amount of exhausts back into the cylinder. Presence of exhausts lowers the combustion temperature and reduces emissions of nitrous oxide.

## **Volvo - where recycling is natural**

As another important part of our commitment to the environment, A35E and A40E are 95% recyclable. Engine, transmission, and hydraulics are overhauled and re-used in our component exchange system. For us, it's natural to assume our responsibility for the environment, of which we all are a part.

## **Quality**

Volvo articulated haulers are manufactured in quality certified factories according to ISO 9001:2000.

Extensive product reliability growth test programs and improved component reliability standards ensure availability and greater productivity in the most demanding operating conditions.

All major components including transmission, axles, fuel tank, and hydraulic tank are well-protected from contamination with high-quality breather filters, only replaced every 2,000 hours to ensure long machine life and prevent oil misting

All electrical wiring is routed through high-quality conduits providing true protection from water, dust, vibration and abrasion

## **Safety**

Dual circuit wheel brake system.

The user-friendly operator's communication system includes safety features such as indication of raised dump body, unbuckled seatbelt, and open door.

The parking brake is activated automatically when the engine is switched off.

The cab has been tested and approved according to the requirements in ROPS ISO 3471 and FOPS ISO 3449.

Non-return valves prevent leakage of both hydraulic tank and fuel tank in case of roll-over.

Warning signs offer clear information in the form of symbols and illustrations.

## **Environment**

Volvo articulated haulers are manufactured in environmentally certified factories according to ISO 14001:2004.

The Volvo D12 and D16 engines meet existing emissions requirements according to EU Stage IIIA and EPA Tier 3.

Optional biodegradable hydraulic oil allows environment-friendly operation.





# ADAPTABLE DUMP BODY



## Selection of Volvo adaptable dump body options

### Extra Front spillguard

Reduces spill from careless loading and when hauling on steep downhill grades.

### Body heating kit

Reduces the risk of material freezing or sticking to the body. The exhaust gases are routed along the bottom of the body via a flexible hose at the hitch and exit at the rear of the body.

### Overhung Tailgate, Wire operated

The wire operated tailgate gives a large opening, and reduces spill when hauling, especially on steep grades. Designed for hauling gravel, sand and liquid masses.

# NINE WAYS TO IMPROVE THE CAPACITY OF YOUR MACHINE



## Selection of Volvo equipment

### Low profile tires

65% profile tires are perfect in demanding applications where low ground pressure, good stability and comfort are preferred.

### Electrical hood opening

Makes hood opening easy and fast. An electric pump opens the hood in addition to the hand operated pump.

### Rear vision system

Rearview camera system reduces blind spots, improves site safety and operator comfort when reversing.

### Heavy-duty oil bath engine air cleaner

Increases functional reliability in extremely dusty conditions.

### Anti-theft system

A four-digit code is entered via the Controninc to enable engine start.

### Engine shut down timer

Delayed engine shut-down, easily activated with a switch on the instrument panel. The delay timer is set with the Controninc System. Gives the turbocharger time to cool down and ensure lubrication of the turbo.

### Arctic / Siberian Kit

Adapts the machine for operation in extremely cold climates. Includes hoses accumulators, oils and lubricants for cold climates.

### Fast fueling - bolt-on kit

Provides easy and fast fueling reducing contamination and spillage.

### Care Track Telematics system

Remote monitoring of the machine's position, utilization and performance. Forwarding of error codes, alarms and service reminders. Position on map plus Geo&Time-fence functions.

# VOLVO A35E, A40E IN DETAIL



## Engine

Engine: Volvo, V-act Tier III, 6-cylinder in-line, direct injected electronically-controlled. Volvo's turbocharged and intercooled 4-stroke diesel engine, generates high torque at low rpm for quick response and low exhaust emissions. Cooling system: High-capacity cooling system with power and fuel saving, variable speed fans.

## A35E

Engine	Volvo D12D AEE3*/AFE3**	
Max power at	30 r/s	1 800 r/min
SAE J1995 Gross	313 kW	419 hp
Flywheel power at	30 r/s	1 800 r/min
ISO 9249, SAE J1349 Net	309 kW	414 hp
Max torque at	20 r/s	1 200 r/min
SAE J1995 Gross	2100 Nm	1 549 lb ft
ISO 9249, SAE J1349 Net	2 056 Nm	1 547 lb ft
Displacement total	12 l	732 in <sup>3</sup>

## A40E FS

Engine	Volvo D16E AAE3*/ABE3**	
Max power at	30 r/s	1 800 r/min
SAE J1995 Gross	350 kW	469 hp
Flywheel power at	30 r/s	1 800 r/min
ISO 9249, SAE J1349 Net	346 kW	464 hp
Max torque at	20 r/s	1 200 r/min
SAE J1995 Gross	2 525 Nm	1 862 lb ft
ISO 9249, SAE J1349 Net	2 493 Nm	1 837 lb ft
Displacement total	16 l	976 in <sup>3</sup>

\*) Meets US (EPA) Tier 3, California (CARB) Tier 3 and Europe (EU) Stage III

\*\*\*) Meets Europe (EU) Stage IIIA

## Drivetrain

Torque converter: Built-in lock-up function. Transmission: Fully automatic Volvo PowerTronic planetary transmission with nine forward gears and three reverse gears. The transmission has the ability to skip gears for fast and accurate gear selection. Dropbox: Volvo-designed with high ground clearance. Axles: Heavy-duty, purpose built Volvo design with fully floating axle shafts, planetary type hub reductions and 100% dog clutch type diff-lock.

## A35E

Torque converter	2,1:1
Transmission, Volvo	PT 2509
Dropbox, Volvo	IL2
Axles, Volvo	ARB/H35

## A40E

Torque converter	2,1:1
Transmission, Volvo	PT 2509
Dropbox, Volvo	IL2
Axles, Volvo	ARB/H40

Engine brake	Exhaust retarder
--------------	------------------



### Electrical system

All cables, sockets and pins are identified. Cables are enclosed in plastic conduits and secured to main frame. Halogen lights. Prewired for options. Connectors meet IP67 standard for water-proofing as necessary.

#### A35E

<b>Voltage</b>	24 V
<b>Battery capacity</b>	2x170 Ah
<b>Alternator</b>	2,24 kW (80 A)
<b>Starter motor</b>	7,0 kW (9,5 hp)

#### A40E

<b>Voltage</b>	24 V
<b>Battery capacity</b>	2x225 Ah
<b>Alternator</b>	2,24 kW (80 A)
<b>Starter motor</b>	7,0 kW (9,5 hp)

### Brake system

Fully hydraulic, wet multiple disc brakes with enclosed, forced oil-cooled multiple discs on all wheels. Two circuits. Separate brake cooling for each axle. Complies with ISO 3450 and SAE J1473 at total machine weight. Circuit division: One circuit for front axle and one for bogie axles. Parking brake: Spring-applied disc brake on the propeller shaft, designed to hold a loaded machine on a grade of up to 18%. When the parking brake is applied, the longitudinal differential is locked. Compressor: Gear-driven by engine transmission. Retarder: Hydraulic, integrated in axles, controlled with a separate pedal.

### Cab

Ergonomically designed. Unobstructed wide angle forward view. Operator centrally positioned above the front axle. Ergonomically positioned controls. Air-conditioning. Adjustable operators seat with retractable seat belt. Filtered fresh air and four speed fan. Operator Communication System: Contronic, user-friendly and easy-to-understand information, all vital machine functions are constantly monitored. Standard: ROPS/FOPS approved according to (ISO3471, SAE J1040) / (ISO3449, SAE J231).

#### A35E / A40E

<b>Sound level in cab ISO 6396</b>	72 dB(A)
------------------------------------	----------

# VOLVO A35E, A40E IN DETAIL



## Hydraulic System

Pumps: Six engine-driven variable displacement load-sensing piston pumps driven by the flywheel PTO. One ground-dependent piston pump for secondary steering mounted on the dropbox. Filter: One fiberglass filter with magnetic core.

A35E	Pump capacity per pump
Engine-dependent	143l/min (37.8 US gpm)
Engine speed	35,0 r/s (2 100 rpm)
Ground-dependent	202 l/min (53.4 US gpm)
at shaft speed	47,5 r/s (2 850 rpm)
Working pressure	25 MPa (3 626 psi)

A40E	Pump capacity per pump
Engine-dependent	143l/min (37.8 US gpm)
Engine speed	33,3 r/s (1 998 rpm)
Ground-dependent	202 l/min (53.4 US gpm)
at shaft speed	47,5 r/s (2 850 rpm)
Working pressure	25 MPa (3 626 psi)

## Steering system

Cylinders: Two double-acting steering cylinders. Supplementary steering: Complies with ISO 5010 at total machine weight. Steering angle: 3,4 steering wheel turns lock-to-lock,  $\pm 45^\circ$ .

## Body / Dumping

Load and dump brake: With the engine running, the service brakes on the rear axle are applied and transmission is shifted to neutral. Dumping Cylinders: Two single stage double acting cylinders.

## A35E

Tipping angle	70° A
Tipping time with load	12 s
Lowering time	10 s

## A40E

Tipping angle	72° A
Tipping time with load	12 s
Lowering time	10 s

## Frames and Chassis

Box type design frames. 360° rotating, high positioned hitch. Independent wheel movement via a 3-point mounting system. Straddle mounted bogie beam.



# SPECIFICATIONS

Pos	Metric (mm)		Imperial (Feet)	
	A35E	A40E	A35E	A40E
A	11 182	11 265	36'8"	37'0"
A <sub>2</sub>	6 242	6 404	20'6"	21'0"
B	5 531	5 820	18'2"	19'1"
C	3 716	3 768	12'2"	12'4"
C <sub>1</sub>	3 545	3 596	11'8"	11'10"
C <sub>2</sub>	1 769	1 769	5'10"	5'10"
D	3 101	3 101	10'2"	10'2"
E	1 278	1 278	4'2"	4'2"
F	4 578	4 518	15'0"	14'10"
G	1 820	1 940	6'0"	6'4"
H	1 683	1 706	5'6"	5'7"
I	650	495	2'2"	1'7"
J	2 939	3 152	9'8"	10'4"
K	2 314	2 455	7'7"	8'1"
L	899	841	2'11"	2'9"
M	7 246	7 284	23'9"	23'11"
N	8 826	8 885	28'11"	29'2"
N <sub>1</sub>	4 423	4 335	14'6"	14'3"
O	3 106	3 374	10'2"	11'1"
O***	3 305	3 497	10'10"	11'6"
P	2 870	3 074	9'5"	10'1"
R	580	628	1'11"	2'1"
R <sub>1</sub>	668	716	2'2"	2'4"
V	2 534	2 636	8'4"	8'8"
V*	2 625	-----	8'7"	-----
W	3 258	3 432	10'8"	11'3"
W)**	3 410	3 570	11'2"	11'9"
X	521	576	1'9"	1' 11"
X1	602	657	2'0"	2'2"
X2	754	806	2'6"	2'8"
Y	2 534	2 636	8'4"	8'8"
Y*	2 625	-----	8'7"	-----
Z	3 258	3 432	10'8"	11'3"
Z)**	3 410	3 570	11'2"	11'9"
a1	23,3°	24,3°	23,3°	24,3°
a2	70°	72°	70°	72°
a3	45°	45°	45°	45°

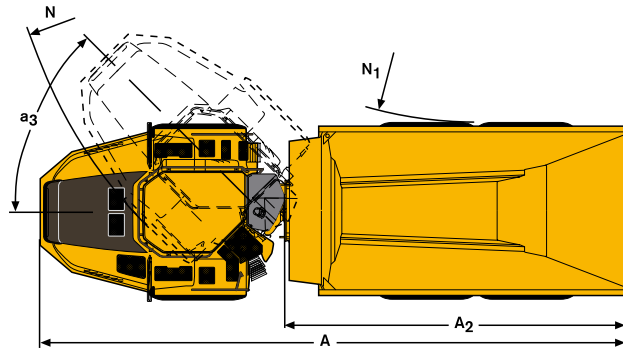
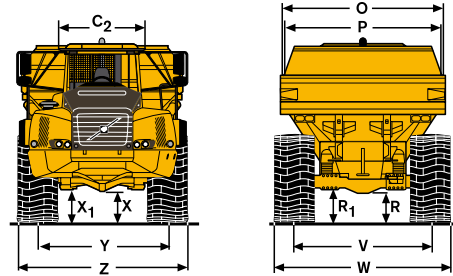
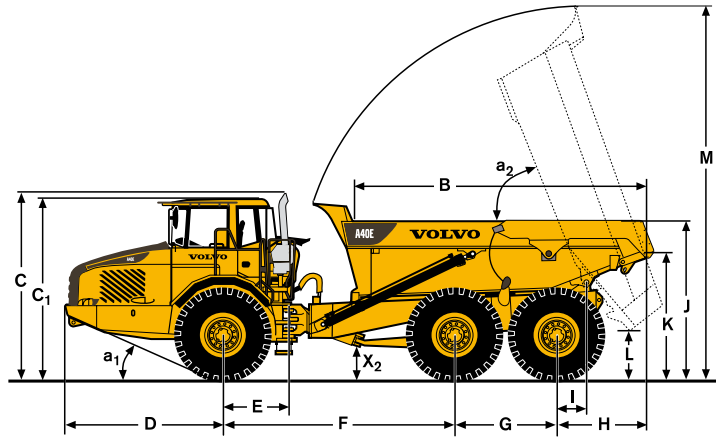

A35E: Unloaded machine with 26,5 R25  
A40E: Unloaded machine with 29,5 R25  
\*) A35E with optional 775/65R29 tires  
\*\*) A40E with optional 875/65R29 tires  
\*\*\*) with overhung tailgate



### Load capacity

	A35E		A40E	
<b>Standard Body</b>				
Load capacity	33 500 kg	37 sh tn	39 000 kg	43 sh tn
Body, struck	16,0 m <sup>3</sup>	20.9 yd <sup>3</sup>	18,4 m <sup>3</sup>	24.1 yd <sup>3</sup>
Body, heaped	20,5 m <sup>3</sup>	26.8 yd <sup>3</sup>	24,0 m <sup>3</sup>	31.4 yd <sup>3</sup>
<b>With overhung tailgate</b>				
Body, struck	16,4 m <sup>3</sup>	21.5 yd <sup>3</sup>	18,8 m <sup>3</sup>	24.6 yd <sup>3</sup>
Body, heaped	21,4 m <sup>3</sup>	28.0 yd <sup>3</sup>	24,7 m <sup>3</sup>	32.3 yd <sup>3</sup>

### Weights

	A35E		A40E	
Tires	26,5R25*		29,5R25**	
<b>Operating weight unloaded</b>				
Front	14 700 kg	32 408 lb	15 700 kg	34 613 lb
Rear	13 400 kg	29 542 lb	14 500 kg	31 967 lb
Total	28 100 kg	61 950 lb	30 200 kg	66 580 lb
Payload	33 500 kg	73 855 lb	39 000 kg	85 980 lb
<b>Total weight</b>				
Front	17 700 kg	39 022 lb	19 650 kg	43 321 lb
Rear	43 900 kg	96 783 lb	49 550 kg	109 239 lb
Total	61 600 kg	135 805 lb	69 200 kg	152 560 lb

Operating weight includes all fluids and operator

\*) A35E with tires 775/65R29, add 200 kg (441 lb)/axle

\*\*) A40E with tires 875/65R29, add 300 kg (661 lb)/axle

### Body material

Front	8 mm	0.31"
Sides	12 mm	0.47"
Bottom	14 mm	0.55"
Chute	16 mm	0.63"
Yield strength	1000 N/mm <sup>2</sup>	145000 psi
Tensile strength	1250 N/mm <sup>2</sup>	181000 psi
Hardness	400 HB	

### Ground Pressure

	A35E				A40E			
Tires	26,5R25		775/65R29		29,5R25		875/65R29	
<b>Unloaded</b>								
Front	123 kPa	17.8 psi	106 kPa	15.3 psi	110 kPa	16.0 psi	96 kPa	13.9 psi
Rear	56 kPa	8.1 psi	49 kPa	7.1 psi	51 kPa	7.4 psi	46 kPa	6.7 psi
<b>Loaded</b>								
Front	148 kPa	21.5 psi	127 kPa	18.4 psi	138 kPa	20.0 psi	120 kPa	17.4 psi
Rear	184 kPa	26.7 psi	157 kPa	22.8 psi	174 kPa	25.2 psi	151 kPa	21.9 psi

### Speed

	A35E		A40E	
<b>Forward</b>				
1	6,2 km/h	3.9 mph	5,8 km/h	3.6 mph
2	9,0 km/h	5.6 mph	8,4 km/h	5.2 mph
3	11,0 km/h	6.8 mph	10,4 km/h	6.5 mph
4	16,0 km/h	9.9 mph	14,9 km/h	9.3 mph
5	23,0 km/h	14.3 mph	21,6 km/h	13.4 mph
6	29,1 km/h	18.1 mph	27,3 km/h	17.0 mph
7	38,5 km/h	23.9 mph	36,0 km/h	22.4 mph
8	50,9 km/h	31.6 mph	47,6 km/h	29.6 mph
9	57 km/h	35.4 mph	57 km/h	35.4 mph
<b>Reverse</b>				
1	6,9 km/h	4.3 mph	6,5 km/h	4.0 mph
2	10,0 km/h	6.2 mph	9,4 km/h	5.8 mph
3	18,0 km/h	11.2 mph	18,0 km/h	11.2 mph

### Fill capacities

	A35E		A40E	
Crankcase	50 liter	13.2 US gal	55 liter	14.5 US gal
Fuel tank	480 liter	126.8 US gal	545 liter	144.0 US gal
Cooling system	100 liter	26.4 US gal	100 liter	26.4 US gal
Transmission, total	38 liter	10 US gal	38 liter	10 US gal
Dropbox	9 liter	2.2 US gal	9 liter	2.2 US gal
Axles, front/rear	48 liter	12.7 US gal	55 liter	14.5 US gal
Brake cooling tank	121 liter	32.0 US gal	121 liter	32.0 US gal
Hydraulic tank	262 liter	69.2 US gal	262 liter	69.2 US gal

## STANDARD EQUIPMENT

<b>Safety</b>	<b>A35E</b>	<b>A40E</b>
ROPS/ FOPS protected cab	•	•
Service platform for ease of service	•	•
Anti-slip material on hood and fenders	•	•
Hazard lights	•	•
Horn	•	•
Protective grille for rear window	•	•
Rearview mirrors	•	•
Retractable 3-inch safety belt	•	•
Secondary steering	•	•
Steering joint locking assembly	•	•
Dump body lock	•	•
Windshield wipers with interval function	•	•
Windshield washers	•	•
Handrails on steps and platforms	•	•

<b>Service and maintenance</b>	<b>A35E</b>	<b>A35E</b>
Electrical hood opening	•	•

<b>Comfort</b>	<b>A35E</b>	<b>A40E</b>
Tilt/telescopic steering wheel	•	•
Air-conditioning	•	•
Cab heater with filtered fresh air and defroster	•	•
Overhead console for radio	•	•
Sun visor	•	•
Tinted glass	•	•
Can holder /storage tray	•	•
Cigarette lighter	•	•
Ashtray	•	•
Space for lunch cooler	•	•
Storage box	•	•
Instructor seat with seat belt	•	•
Sliding window	•	•

<b>Engine</b>	<b>A35E</b>	<b>A40E</b>
Direct injected, electronically controlled	•	•
Turbocharged, intercooled	•	•
Remote oil drain plug and hose	•	•
Remote oil filters, for ease of access	•	•
Preheater for easier cold starts	•	•
Exhaust retarder	•	•
Delayed engine stop – engine cool down	•	•

<b>Electrical system</b>	<b>A35E</b>	<b>A40E</b>
80 A alternator	•	•
Battery disconnect switch	•	•
Extra 24 V socket for lunch cooler	•	•
Lights:	•	•
• Headlights	•	•
• Parking lights	•	•
• Direction indicators	•	•
• Rear lights	•	•
• Back-up light	•	•
• Brake lights	•	•
• Cab lighting	•	•
• Instrument lighting	•	•

<b>Cab</b>	<b>A35E</b>	<b>A40E</b>
Air suspended, heated, fully adjustable operator's seat	•	•
Volvo Radio with CD player	•	•

<b>Operator information interface</b>	<b>A35E</b>	<b>A40E</b>
Gauges:	•	•
• Speedometer	•	•
• Tachometer	•	•
• Brake pressure	•	•
• Fuel	•	•
• Transmission oil temperature	•	•

<b>Warning lights grouped and easy to read</b>	<b>A35E</b>	<b>A40E</b>
Central warning (3 levels) for all vital functions	•	•

<b>Central positioned information display:</b>	<b>A35E</b>	<b>A40E</b>
• Automatic pre-start checks	•	•
• Operation information, easy-to-find menu	•	•
• Troubleshooting diagnostics	•	•
• Hour meter	•	•
• Clock	•	•

<b>Drivetrain</b>	<b>A35E</b>	<b>A40E</b>
Automatic transmission	•	•
Torque converter with automatic lock-up in all gears	•	•
Single stage dropbox	•	•
6x4 or 6x6 operator selectable drive modes	•	•
100% longitudinal differential lock	•	•
100% differential locks in all axles	•	•

<b>Brakes</b>	<b>A35E</b>	<b>A40E</b>
Two circuit, fully hydraulic brakes with enclosed, forced oil-cooled, multiple wet discs on all axles.	•	•
Parking brake on prop shaft	•	•

<b>Body</b>	<b>A35E</b>	<b>A40E</b>
Body prepared for exhaust heating	•	•

<b>Tires</b>	<b>A35E</b>	<b>A40E</b>
26.5R25	•	•
29.5R25		•

<b>Other</b>	<b>A35E</b>	<b>A40E</b>
Toolbox	•	•
Care Track Telematics System	•	•

## OPTIONAL EQUIPMENT

### Safety

**A35E****A35E**

Fire-extinguisher and first aid kit	•	•
-------------------------------------	---	---

### Service and maintenance

**A35E****A35E**

Tool kit with tire inflation unit	•	•
-----------------------------------	---	---

### Engine

**A35E****A40E**

Air cleaner, heavy-duty, dry type	•	•
Air cleaner, oil-bath type	•	•
Electric engine heater (120V)	•	•
External emergency engine stop	•	•
High idle engine work speed	•	•

### Electrical

**A35E****A40E**

Work lights, roof mounted	•	•
Work lights, rear-facing, fender-mounted	•	•
Rotating beacon, collapsible mount	•	•
Back-up alarm	•	•
Rear vision system	•	•
Anti-theft system (prevents engine start)	•	•

### Cab

**A35E****A40E**

Electrically heated rearview mirrors	•	•
Cable kit for cab heater (120V)	•	•
Window tint film	•	•

### Body

**A35E****A40E**

Body exhaust heating	•	•
Extra front spillguard	•	•
Overhung tailgate, wire operated	•	•
Wear plates	•	•

### Tires

**A35E****A40E**

775/65R29	•	
875/65R29		•

### External

**A35E****A40E**

Mudguard wideners for low profile tires	•	•
---	---	---

### Other

**A35E****A40E**

Synthetic hydraulic oil (biologically degradable)	•	•
Arctic oil kit	•	•
Siberian kit, -40°C	•	•
Fast fueling bolt-on kit	•	•



Volvo Construction Equipment is different. The company's products are designed, built and supported in a different way. That difference comes from our 175-year engineering heritage. A heritage of thinking first about the people who actually use the machines. About how to make them safer, more comfortable, more productive. About the environment we all share. The result of that thinking is a growing range of machines and a global support network dedicated to helping you do more. People around the world are proud to use Volvo. And we're proud of what makes Volvo different - **More care. Built in.**



*Not all products are available in all markets. Under our policy of continuous improvement, we reserve the right to change specifications and design without prior notice. The illustrations do not necessarily show the standard version of the machine.*

# **VOLVO**

**Volvo Construction Equipment**  
[www.volvoce.com/na](http://www.volvoce.com/na)

Ref. No. 22 A 100 3155  
Printed in USA 11/07 - 5,0  
Volvo, Asheville

English  
USA