

VOLVO ARTICULATED HAULER

A350

CONTAINER HAULER

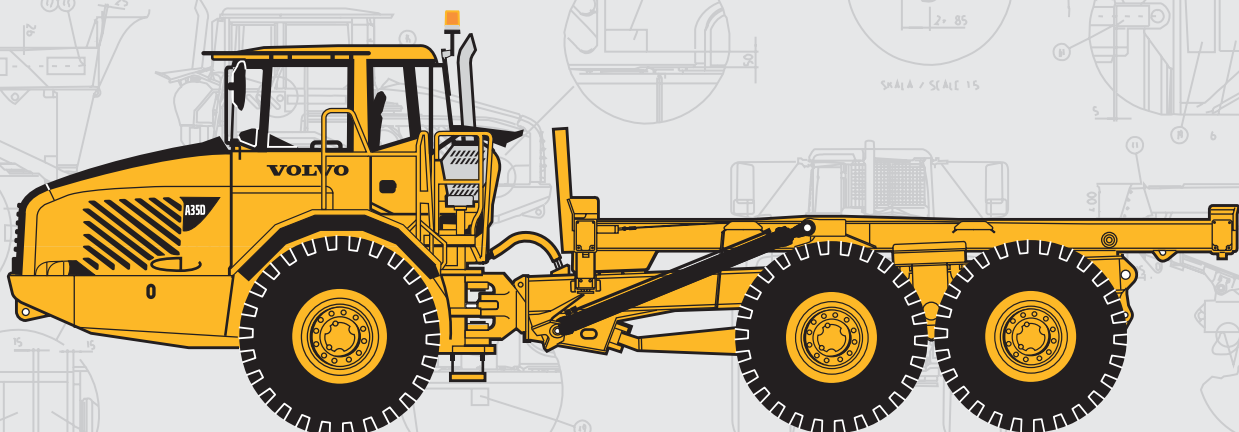

- **Engine output:**
SAE J1995, Gross 289 kW (393 hp)
SAE J1349, Net 285 kW (389 hp)
- **Load capacity:**
32,5 t
- **Designed to handle 20 ft ISO container.**
- **Dumping angle 49°.**
- **Cab operated container lock.**
- **Volvo cab**, designed for high operator visibility, ergonomics and comfort.
- **Reduced maintenance time**, no daily or weekly grease points.
- **Electronic Operator's Communication System**
- **Volvo high performance – low emission**, electronically controlled direct injected, turbocharged, intercooled diesel engine.
- **Fully automatic planetary transmission**, electronically controlled.
- **Hydraulic retarder** integral in transmission.
- **Dropbox with longitudinal differential lock**
- **100% lock-up differentials.** One longitudinal and three transverse differential locks.
- **Front axle with three-point suspension.**
- **Volvo terrain bogie**, individually oscillating axles and high ground clearance.
- **Volvo Load & Dump Brake.**

VOLVO

The A35D Container Hauler in detail

Service

The computerized information system monitors all fluid levels, minimizing daily and weekly service times.

Time to next service and the status of vital vehicle systems is shown to the operator on a display in the instrument panel.

Service accessibility: Fold-down front grill with access ladder to remote filter bank, located in front of engine. Large, 90° opening hood for total engine access. Remote drain hoses and swing-out radiator for easy cleaning.

Fill capacities

Crankcase.....	50 l
Fuel tank.....	480 l
Cooling system	117 l
Transmission total	48,5 l
Dropbox.....	10,5 l
Per axle	48 l
Hydraulic tank	250 l

Engine

Volvo inline 6-cylinder, direct injected electronically controlled, turbocharged, intercooled 4-stroke low-emission diesel engine with wet replaceable cylinder liners.

Fan: Hydrostatically driven, thermostatically controlled variable speed radiator fan consuming power only when needed.

Engine brake: VEB (Volvo Engine Brake) includes compression and exhaust brake.

Make, model	Volvo D12D AAE2*/AAE3**
Max power at	30 r/s (1 800 r/min)
SAE J1995 Gross	289 kW (393 hp)
Flywheel power at	30 r/s (1 800 r/min)
SAE J1349 Net, DIN 6271***	285 kW (388 hp)
Max torque at	20 r/s (1 200 r/min)
SAE J1995 Gross	1 950 Nm
SAE J1349 Net, DIN 6271***	1 915 Nm
Displacement total	12 l

With fan operating at full speed, the flywheel power is 277 kW (377 hp) and maximum torque is 1 860 Nm which corresponds to DIN 70020.

*) Meets US (EPA) Tier 2, California (CARB)

Tier 2 and Europe (EU) Stage 2.

**) Meet US (EPA) Tier 3.

***) with fan at normal speed.

The D12D engine is emission certified as a Family Engine with the following output data:

Rated power at	31,7 r/s (1 900 rpm)
SAE J1995 Gross	280 kW (381 hp)
Max torque at.....	20 r/s (1 200 r/min)
SAE J1995 Gross	2100 Nm

Electrical system

All cables, sockets and pins are identified. Cables are enclosed in plastic conduits and secured to main frame.

Halogen lights. Prewired for options.

Connectors meet IP67 standard for waterproofing as necessary.

Voltage	24 V
Battery capacity	2x170 Ah
Alternator	1,54 kW (55 A)
Starter motor	7,2 kW (10 hp)

Drivetrain

Volvo components, specifically designed for hauler applications.

Torque converter: Single-stage with free-wheeling stator and automatic lock-up on all gears.

Transmission: Electronically controlled, fully automatic planetary transmission with six forward gears and two reverse gears, with a built-in variable hydraulic retarder.

Dropbox: Volvo design with high and low function, power take-off and differential with 100% lock-up function. Separate dropbox oil cooling.

Axles: Volvo design with fully floating axle shafts and planetary type hub reductions.

Differential locks: One longitudinal and three transverse with 100% lock-up function, operator selectable on the move.

Configuration: 6x4 or 6x6 drive, operator selectable on the move.

Torque converter.....	1,95:1
Transmission, Volvo	PT 1862
Dropbox, Volvo	FL 992
Axles, Volvo	AH 64

Speed:

Low gear forward	
1	5 km/h
2	8 km/h
3	15 km/h
4	21 km/h
5	27 km/h
6	35 km/h

High gear forward	
1	9 km/h
2	13 km/h
3	23 km/h
4	34 km/h
5	43 km/h
6	56 km/h

Low gear reverse	
1	5 km/h
2	9 km/h

High gear reverse	
1	8 km/h
2	14 km/h

Brake system

Fully hydraulic brakes on all axles. Two circuits. Well protected components.

Meets ISO 3450 and SAE J1473 at total machine weight.

Service brakes: Dry discs on all wheels.

Circuit division: One circuit for front axle and one for bogie axles.

Parking brake: Spring-applied disc brake on the propeller shaft, designed to hold a loaded machine on a grade up to 18%. When the parking brake is applied, the longitudinal differential is locked.

Compressor: Gear-driven by engine transmission.

Retarder: Hydraulic, infinitely variable, integrated in transmission. Total retarding capability including transmission retarder and exhaust retarder, see graph.

Volvo Engine Brake: Standard. Operator selectable application together with service brakes or when accelerator pedal is released. Always engaged together with retarder. Total retarding capability including transmission retarder and engine brake, VEB, see graph.

Steering system

Hydromechanical self-compensating articulated steering for safe and accurate high-speed hauling. Fast acting, low effort steering with 3,4 turns lock-to-lock for slow speed maneuverability.

Cylinders: Two double-acting steering cylinders.

Secondary steering: Meets ISO 5010 at total machine weight.

Steering angle: ±45°

Suspension

Volvo's unique maintenance-free 3-point suspension system. The axles are suspended at three points, which results in independent movement needed in rough terrain.

Front axle: The front suspension consists of one rubber spring, a stabilizer and three shock absorbers on each side.

Bogie: Volvo's unique terrain bogie permits long suspension travel and independent wheel movement, keeps the body level, retaining the load.

Cab

Volvo cab, ergonomically designed for high operator comfort and excellent visibility. Wide threshold-free door opening and ergonomic cab entrance. Insulating rubber pads to reduce vibrations. Tilt/ telescopic steering wheel. Overhead console for radio. Dash-mounted Operator's Communication System. Storage bins.

Standard: ROPS/FOPS tested and approved. (ISO 3471, SAE J1040) / (ISO 3449, SAE J231) standards.

Heater and defroster: Filtered fresh air, four-speed fan and pressurized cab to maintain a clean operating environment. Multi-level air outlets and separate defroster vents for all windows.

Operator's seat: Fully adjustable, mechanically or air suspended operator's seat with flameproof upholstery. Retractable seat belt.

Trainer seat: Standard, with seat belt and back rest.

Sound level in cab: ISO 6396 .. 72 dB (A) at max. speed..... 76 dB (A)

Weights		Ground Pressure			Load Capacity	
Operating weight includes all fluids and operator.		At 15% sinkage of unloaded radius and specified weights.			Total weight including container.	
Tires	A35D	Tires	A35D			A35D
	26.5 R25		23.5R25	775/65R29		
Operating weight unloaded		Unloaded			ISO Container 20ft	
Front	15 120 kg	Front	128 kPa	107 kPa	Load capacity	32 500 kg
Rear	10 830 kg	Rear	46 kPa	38 kPa		
Total	25 950 kg	Loaded				
Payload	32 500 kg	Front	139 kPa	116 kPa		
Total weight		Rear	178 kPa	148 kPa		
Front	16 440 kg					
Rear	42 000 kg					
Total	58 440 kg					
*) A35D with tires 775/65R29, add 100 kg/ axle						

Hydraulic system

Load-sensing variable displacement piston pumps consume power only when needed.

Pumps: Seven engine-driven, variable displacement, load-sensing piston pumps driven by the flywheel PTO. One ground-dependent piston pump for secondary steering mounted on the dropbox.

Filtration: Through two fibreglass filters with magnetic cores.

Pump capacity per pump:

Engine-dependent 143 l/min
 Ground-dependent 202 l/min
 at shaft speed 47,5 r/s (2 850 r/min)
 Working pressure 25 MPa

Container frame

Each corner of the container frame is equipped with air operated container locks that are maneuvered from the cab.

Dump Cylinders: Two single-stage double-acting cylinders.

Tipping angle 49°
 Tipping time with load 8 s
 Lowering time 6 s

Specifications A35D Container Hauler

Pos	Metric (mm)
	A35D
A	11 167
A ₂	6 224
B	5 527
C	3 681
C ₁	3 560
C ₂	1 768
D	3 101
E	1 276
F	4 501
G	1 820
H	1 757
I	728
K	2 302
L	915
M	7 242
N	8 720
N ₁	4 397
O	3 103
R	584
R ₁	670
U	3 528
V	2 515
V*	2 625
W	3 208
W*	3 410
X	572
X ₁	606
X ₂	720
Y	2 515
Y*	2 625
Z	3 208
Z*	3 410
a ₁	23°
a ₂	49°
a ₃	45°

*) with optional 775/65R29 tires

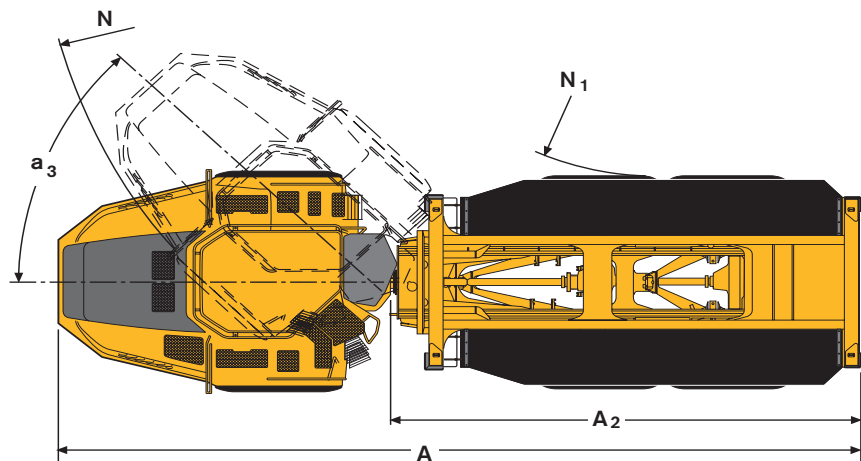
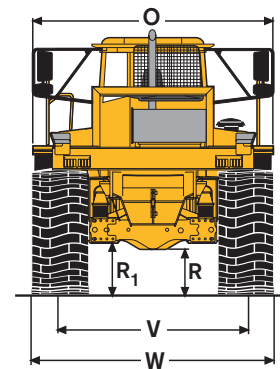
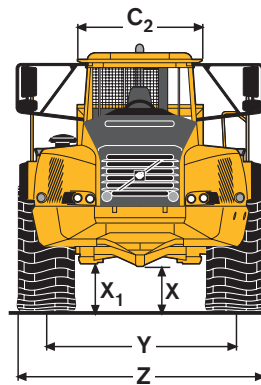
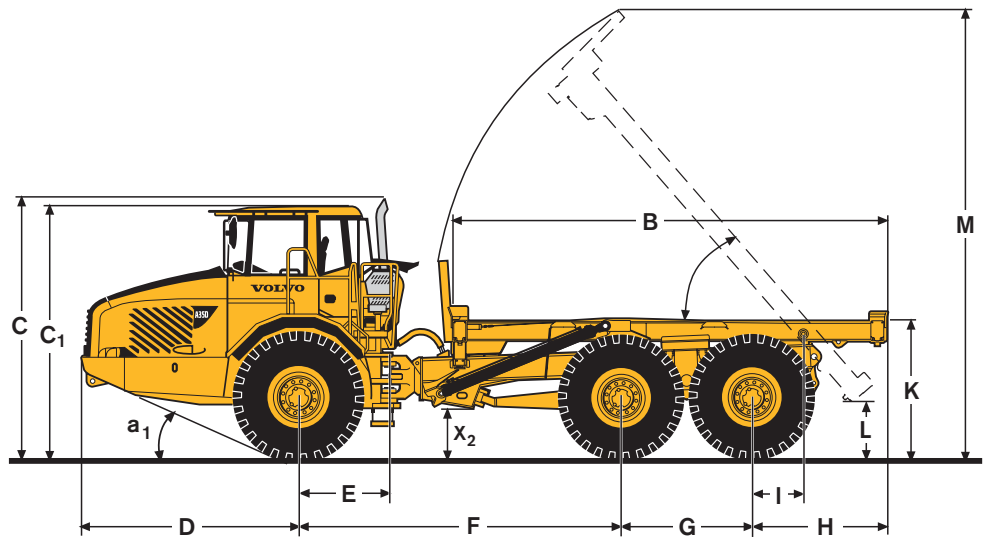

STANDARD EQUIPMENT

Safety

ROPS/ FOPS cab
Service platform for ease of service
Anti-slip material on fenders and hood
Hazard lights
Horn
Protective grille for rear window
Rear-view mirrors
Retractable 3-inch safety belt
Secondary steering
Steering joint locking assembly
Dump body lock
Handrails on fenders
Windshield wipers with interval function
Windshield washers

Comfort

Tilt/ telescopic steering wheel
Cab heater with filtered fresh air and defroster
Overhead console for radio
Sun visor
Tinted glass
Can holder / storage tray
Cigarette lighter
Ashtray
Space for lunch cooler
Storage box
Instructor seat with backrest and retractable seat belt

Engine

Direct injected, electronically controlled
Volvo Engine Brake, VEB
Turbocharged
Intercooler, air-to-air cooler
Remote oil filters, for ease of access
Remote oil drain plug and hose
Preheater for easier cold starts
Coolant filter

Electrical system

Alternator, 55 A
Battery disconnect switch
Electrical outlets, 24V in cab
Lights:
• Headlights
• Parking lights
• Direction indicators
• Rear lights
• Back-up lights
• Brake lights
• Cab lighting
• Instrument lighting
Pilot lights for all switches

Operator information interface

Gauges:
• Speedometer
• Tachometer
• Brake pressure
• Fuel
• Transmission oil temperature

Warning lights grouped and easy to read
Central warning (3 levels) for all vital functions

Central positioned information display:
• Automatic pre-start checks
• Operation information, easy-to-find menu
• Troubleshooting diagnostics
• Hour meter
• Clock
• Machine settings

Drivetrain

Automatic transmission
Torque converter with automatic lock-up
Variable hydraulic transmission retarder
Dropbox with high/low range
6x4 or 6x6 operator selectable drive modes
100% longitudinal differential lock
100% differential locks in all axles

Brakes

Two circuit, fully hydraulic disc brakes on all axles.
Volvo Engine Brake (VEB) activation in brake pedal
Parking brake on prop shaft

Container frame

Container frame for 20' ISO container with remote controlled container locks
Headboard for container frame
Container corner guidings
Sidemounted dumping cylinders
Tail light mounted in the back of the container frame
Roof mounted beacon (red) indicating "container lock open"
Hydraulic lock to prevent dumping container if not all container locks are engaged

Tires

26,5R25

Other

Air drier
Tool box

OPTIONAL EQUIPMENT

Safety

Fire-extinguisher and first aid kit

Service and maintenance

Tool kit with tire inflation unit
Electrical hood opening

Engine

Extra air cleaner, heavy-duty
Extra air cleaner, oil bath type
External emergency stop
Delayed engine stop
Engine coolant pre-heater (120V or 240V)
Engine and cab heater, diesel **
Fast fuel filling system
Precleaner (Sy-klone) **

Electrical

Work lights, roof mounted
Work lights, rear-facing, fender-mounted
Rotating beacon, collapsible mount
Rotating beacon at rear end **
Back-up alarm
Rear vision system
Anti-theft system (prevents engine start)
Headlights for left-hand traffic
Alternator, heavy-duty 80 A
Battery charger **
Jump start connection, NATO **
Back up light, extra **
Cab heater, electrical **
Hazard light when reversing **

Side mounted position lights on container frame **
Voltage converter 24V to 12V, 20 amp **
Rear Vision system, color (Intec) **
Battery main switch located in cab **

Cab

Heated, mechanically or air suspended, fully adjustable operator's seat
Seat cover **
Instructor seat with seat belt
Electrically heated rear-view mirrors
Air conditioning
Radio installation kit
Radio
Cable kit for cab heater (120V or 240V)
Window tint film
Precleaner (Sy-klone) **

Brakes

Fully hydraulic, forced oil-cooled wet disc brakes
Brake guards

Container frame

Dumping angle limitation (hydraulic) **
Unlocking mechanism for tailgate (air) including controls **
Side inclination angle indicator for rear frame **

Tires

775/65R29

External

Mudguard wideners (for 775/65R29 tires)
Rear mudflaps and rubber guards over bogie **
Belly plates for trailer A-stay **

Other

Synthetic hydraulic oil (biologically degradable)
Arctic oil kit

(** Special Optional Equipment)

Under our policy of continual product improvement, we reserve the right to change specifications and design without prior notice. The illustrations do not necessarily show the standard version of the machine.

VOLVO

Construction Equipment

Ref. No 21 6 669 4158 English
Sweden 2005-05 ART
Volvo Växjö