

VOLVO ARTICULATED HAULERS

A20C, A25C, A30C, A35C, A40



VOLVO

Lowest cost per tonne

Volvo's articulated haulers are developed to perform haulage duties at the lowest possible cost under all types of conditions. Here lies the key to the success enjoyed by Volvo's articulated haulers and the reason why they are being used more and more all over the world in a steadily growing number of applications.

A Volvo articulated hauler AB can be manoeuvred onto virtually any loading site, get out with a full load and drive the shortest distance to the dumping site, whether there is a road or not. Here it can be quickly manoeuvred into the right position, dump directly over an edge and therefore often manage without a crawler dozer. All of this means high haulage capacity at a lower cost per tonne.

100 percent Volvo

Volvo Articulated Haulers AB and Volvo Construction Equipment are fullfledged members of the Volvo Group. This gives us access to the enormous resources that are invested by Volvo in new products and support services and all the knowledge obtained from the concept studies conducted by Volvo.

Volvo Construction Equipment with all its products and services also embodies fully and completely Volvo's core values: Quality, Safety and Environment.



Thanks to in-house development and in-house production of the basic components in each articulated hauler, we can guarantee quality, one of the keys to high availability and high productivity.

Volvo has long led the industry when it comes to safety, and that applies equally to construction equipment. Volvo's articulated haulers, for example, have a hydromechanical steering system which gives the operator distinct steering with a perfect "driving feel". An ergonomical design means that every consideration is given to the human being behind the wheel, resulting in high working safety.

Consideration for the environment is becoming increasingly important all over the world. For several years now, Volvo has offered low-emission engines that meet all current environmental requirements, most of the components are recyclable, the climate control systems are CFC-free, etc. The goal is to achieve the best possible interaction between man, machine and environment – still at the lowest cost per hauled tonne.

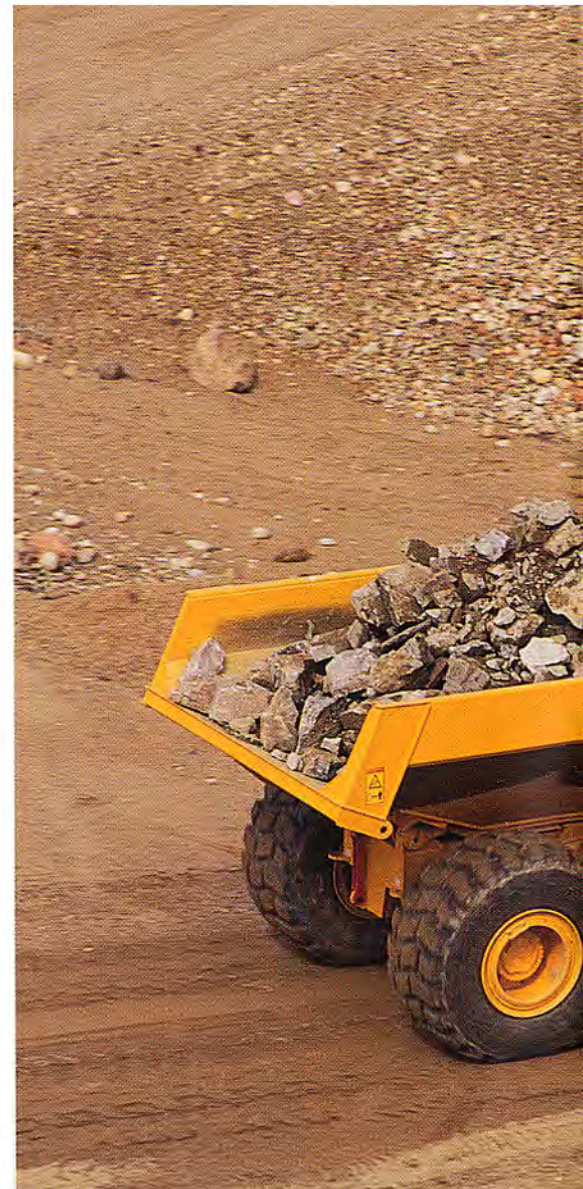



A proud pedigree

The articulated hauler was born and bred in the province of Småland, Sweden, famous for its inventive and enterprising inhabitants and its rugged, unforgiving landscape. From the beginning it was developed for demanding conditions on muddy, hilly terrain and a harsh climate.

The first to discover the advantages of Volvo's articulated haulers were roadbuilders in Scandinavia and northern Europe. The benefits of not having to build roads or prepare the ground for the construction machines were immediately apparent. The articulated hauler's ability to work in all conditions resulted in more working days and more efficient operation.

Since then the articulated hauler has spread to virtually all corners of the globe and is today the leading alternative in many countries. Its predominant area of application is still earthmoving, but new applications are constantly being found. Sand pits, logging, refuse handling, coal mining, tunnel construction, quarries and open-cast mines are just some examples.

Volvo has always been in at the cutting edge of development and has delivered more than half of all the articulated haulers in the world. Development continues unabated, and Volvo's articulated haulers constantly give increased productivity through better off-road mobility, higher speeds, better comfort, lower fuel consumption and lower emissions. They are still developed in Sweden, and always with the ultimate purpose of lower costs per hauled tonne.



The articulated hauler method

The use of Volvo articulated haulers has led to a whole new way to plan a worksite and carry out haulage. It is by truly exploiting all the features of the articulated hauler that the work can be made more efficient:

- All-terrain – able to choose the shortest route, even with a full load, and able to work under virtually all conditions.
- Easy to manoeuvre – comes quickly into position for loading and unloading.
- Dumps over the edge – can usually manage without help on the dumping site.

Right partner

The articulated hauler has a very wide range of applications. It can handle haul distances from 150 metres up to several kilometres, sometimes even longer, with ease and efficiency. On- or off-road, level ground or steep slopes, the versatility of the articulated hauler is great and always makes it worth considering as an alternative. Choosing the right equipment to use in combination with the articulated hauler and never mixing different hauler sizes in the same fleet are other important considerations.

- Great flexibility
- Can be combined with different loading equipment
- On- or off-road
- Dumps with precision – usually without assistance

Loading options

A hydraulic excavator is the most common, and in most cases, the most efficient loading option. Excavator and hauler are combined so that the body is filled with 3-5 buckets. A wheel loader may be the most efficient choice for loading loose materials. It moves rapidly and can load a hauler quickly with its big bucket.

Conveyor belts, silos and other stationary equipment are also excellent choices for loading an articulated hauler. Because the hauler is so easy to manoeuvre, the operator can quickly get into the right position and just as easily get out with a full load.

Haulage with load

Perhaps the strongest side of the articulated hauler. Volvo articulated haulers can get to where they're going under most conditions. The need to build and maintain haul roads is minimal, not even lay-bys are normally needed.

Articulated steering and the frame joint are the keys to this off-road mobility. They are what enable the tractor and trailer units to move independently of each other and eliminate the stresses on the frame. They also make the machine very easy to operate.

Six-wheel drive, diff-locks on all axles and automatic transmission are Volvo features that give the articulated haulers unequalled off-road mobility. The front axle suspension and the Volvo bogie cushion both the load and the operator for a safe and comfortable ride.

The machine can go almost anywhere, and is fast and efficient on construction roads as well.

Unloading

Volvo articulated haulers can dump their loads at exactly the right place. In most cases they need no assistance from crawler dozers or other machines.

Its off-road characteristics and big wheels with low ground pressure enable the articulated hauler to get into position quickly and safely, without the risk of getting stuck.

Once in position, the machine tips quickly, with a body angle of up to 70 degrees. The hydraulic system is double-acting, so the body can be lowered even if the hauler is on an uphill grade. Thanks to the terrain bogie, the high tipping joint, and the chute that guides the material out of the body, it is easy to dump over an edge, directly down into a pit, a hopper or down a slope.





A day on the job

Volvo's articulated haulers are at work all over the world, round the clock, in increasingly diverse applications. In many cases they have been chosen for the task because other methods have been tried and simply haven't worked. Harsh climate, difficult terrain, high demands on availability – these are factors that have influenced the choice of Volvo articulated haulers.

Construction of high-speed trains in Europe, work under ground in South America and haulage at an open-cast mine in Africa – these are just three examples from a steadily growing number of applications.

Borderless Europe needs transport networks

The need for better and faster transport is becoming increasingly urgent in Europe, and enormous resources are being invested in expansion of the infrastructure.

A huge project has been completed in southern Belgium to prepare the way for the high-speed TGV trains which link a growing number of European capitals.

No less than 2.5 million cubic metres of surplus soil had to be excavated and moved to the dumping site, an abandoned mine. The haul distance was about 3.5 km, and from the start it was planned that the job would be done by conventional

trucks. But a combination of muddy, clayey and slippery soil and demanding conditions on both the loading and dumping sites made this impossible. The trucks simply couldn't get through, nor could they dump at the right place.

The solution was to use 65 Volvo articulated haulers, mostly A35s, working double shifts or more to get the job done. The results were very good. The contractors were all very pleased with their haulers, and even though they were operated for as much as 320 hours a month, reliability was very high. Their outstanding off-road mobility was also a very valuable asset. The haul surface is muddy clay, extremely slippery when wet, but the haulers kept production going regardless of conditions.

65 Volvo articulated haulers during the work of moving 2.5 million cubic metres of soil to prepare the way for the high-speed TGV train in southern Belgium.



Sweaty in Zimbabwe

Temperatures over 40°C and slopes with a 12% gradient, 20 hours a day, five days a week – this is the situation faced by four Volvo A25Cs in the Sanyati Copper Mine in Zimbabwe.

The articulated haulers are loaded with shot rock, which is hauled 800 metres to the concentration plant. The haul run is downhill, with a gradient of up to 12%. The retarder comes in very handy here.

To minimize wear on the brakes, the operators are encouraged to use the retarder as much as possible. And with experienced operators this works very well, so well that the brakes virtually never need to be used.

Under ground in Chile

Three Volvo A25Cs work round the clock in a 2 km long haulage tunnel in a copper mine in Chile. They run continuously from the tunnel face out to the portal, where a couple of

Volvo wheel loaders take over. Thanks to their low-emission engines, the articulated haulers can operate continuously down in the mine passageway, without jeopardizing the environment for those who work there.

Despite this very tough schedule, reliability has been 100 percent, largely thanks to the fact that maintenance and inspections have been planned and carried out with great thoroughness. Easy daily checkup routines for the operator is another factor that keeps reliability high.



Dark and cramped, with bad air and slopes with a gradient of up to 14%. Plus round-the-clock duty and loads of 22.5 tonnes. The three Volvo A25Cs used in the Chilean copper mine have a tough job. Despite this, availability has been virtually 100%!

The Sanyati Copper Mine in Zimbabwe has haul roads with steep gradients. But despite a full load and a downhill gradient of up to 12%, the retarder is usually all that is needed, which means the brakes can rest.



Advanced technology for good economy

Volvo articulated haulers are developed and built for demanding haulage under tough conditions. Every detail is made to fill its particular function. Volvo has led the development of technology in this field from the very start. Thanks to this carefully engineered and thoroughly tested concept, Volvo's articulated haulers provide unmatched reliability, productivity and economy – in both the short and long run.

Unique frame and steering joint

What makes the articulated hauler unique, and distinguishes it from other haulage vehicles, is the frame joint and the steering joint. The frame joint connects the front and rear frames together and rotates 360°. The tractor and trailer sections move independently of one another, reducing the stresses in off-road operation and keeping the wheels in contact with the ground. Thanks to the function of the frame joint, the frame can be made properly stiff and robust.

The steering joint makes articulated steering possible, which makes the hauler very easy to manoeuvre in small spaces. Articulated steering also enables the operator to get loose from mud and muck by utilizing the steering force and "slithering" from side to side with the tractor section.

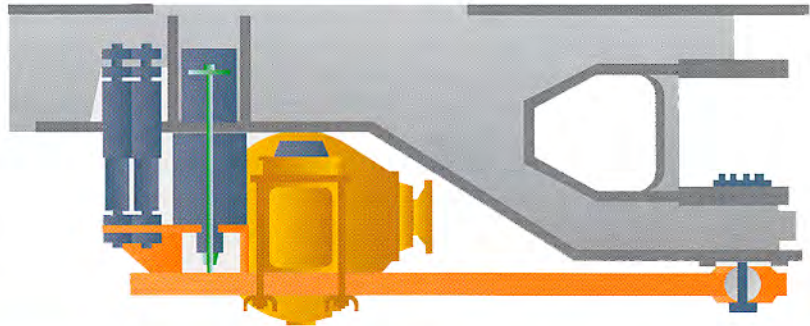

- Genuine Volvo diesel engines
- Unique frame and steering joint
- Suspension in front, bogie in rear
- Drive on all wheels and 100% diff-locks
- Automatic transmission
- Efficient brakes and wear-proof retarder
- Tyres that gives a low ground pressure
- Hydromechanical steering – exact and with good feel

Exact steering

The steering on Volvo's articulated haulers is hydromechanical, which provides very good "driving feel" – equal to that of a modern truck. The steering angle is always the same for a given turn of the wheel, making the machine easy to drive. An important safety feature is that the hauler can always be steered as long as the wheels are rolling, even if the engine is dead.

Suspension and bogie

The front axle with three-point suspension and the terrain bogie are unique Volvo features. The front axle has robust maintenance-free rubber springs. Together with the shock absorbers, they make it possible to maintain a high average speed over difficult terrain, with undiminished operator comfort and low stresses on the machine.

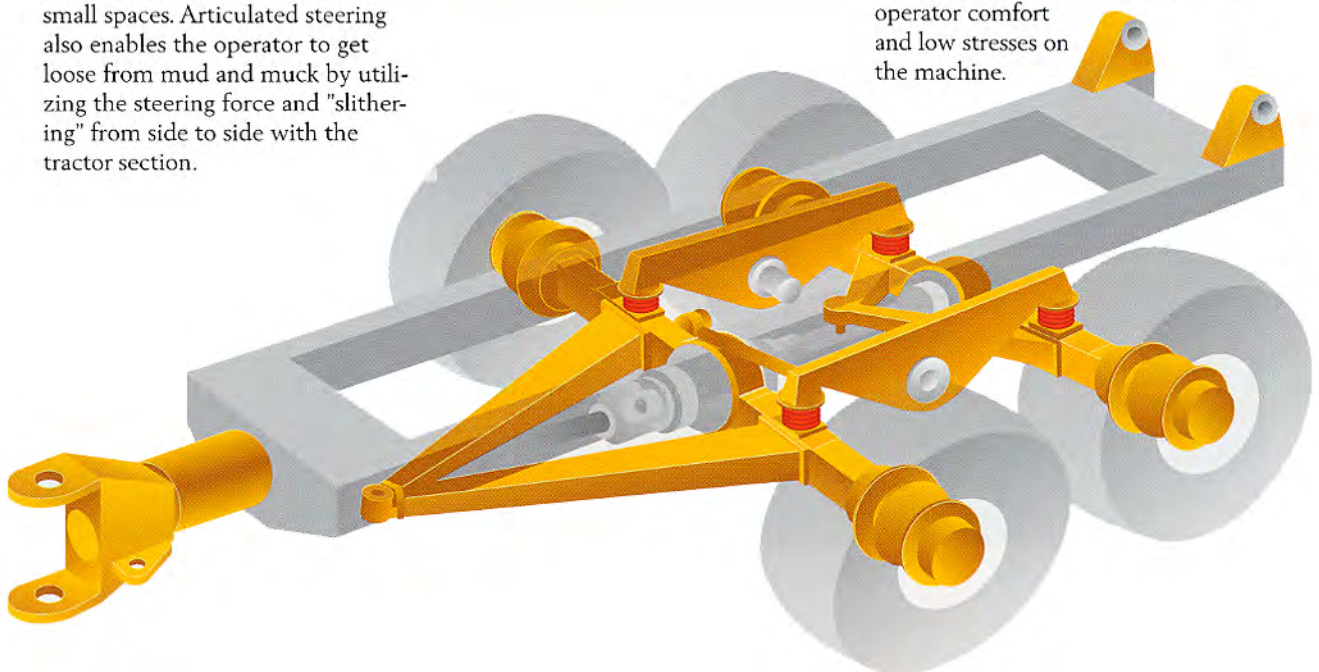

Each bogie axle is suspended at three points, a solution which permits each wheel pair to move freely and the body to "float" over the ground irregularities. Compared with other systems, the three-point suspension provides greater freedom for the wheel pairs to move individually, reducing the stresses on the frame. The Volvo bogie also permits high ground clearance, and the drive axles are well-protected. The design is simple without lube points and is in principle maintenance-free.

Drive on all wheels and 100% diff-locks

All Volvo articulated haulers have the option of drive on all wheels and diff-locks, longitudinal and transverse. For each situation, the operator can choose the most suitable drive combination, the number of driving wheels and locked or open differentials. A skilled operator always uses the smallest number of drive wheels and has as few diff-locks as possible engaged to extend the life of the tyres and keep fuel consumption down. At the same time, effective diff-locks (100% lock-up) are available for use in difficult conditions.

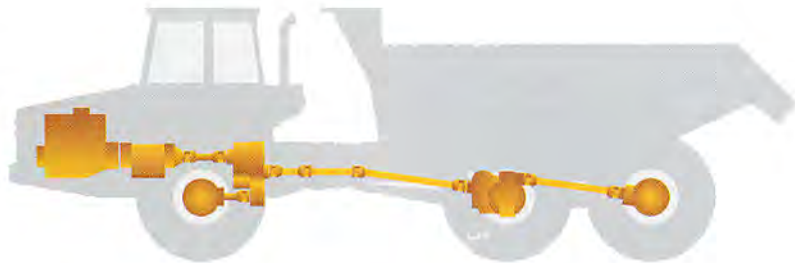

The three-axle articulated haulers allow five drive combinations:

- 6 x 4 without diff-locks is most economical under good driving conditions.
- 6 x 4 with transverse diff-lock on the front axle improves tractive force without reducing steering capacity on slippery surfaces.
- 6 x 6 with longitudinal diff-lock further enhances off-road mobility, and the hauler is still easy to steer.
- 6 x 6 with longitudinal diff-lock and transverse diff-lock on the front axle makes it easier to steer up out of deep ruts to get better traction under the wheels.

- 6 x 6 with all diff-locks engaged offers maximum off-road mobility, and the hauler can negotiate almost any kind of terrain.

Automatic transmission

Studies have shown that an operator in an articulated hauler with manual power shift changes gear 150–180 times per hour! The advantages of automatic transmission are therefore pretty obvious. For optimum utilization of engine power, the automatic transmission has torque converter lock-up in all gears.

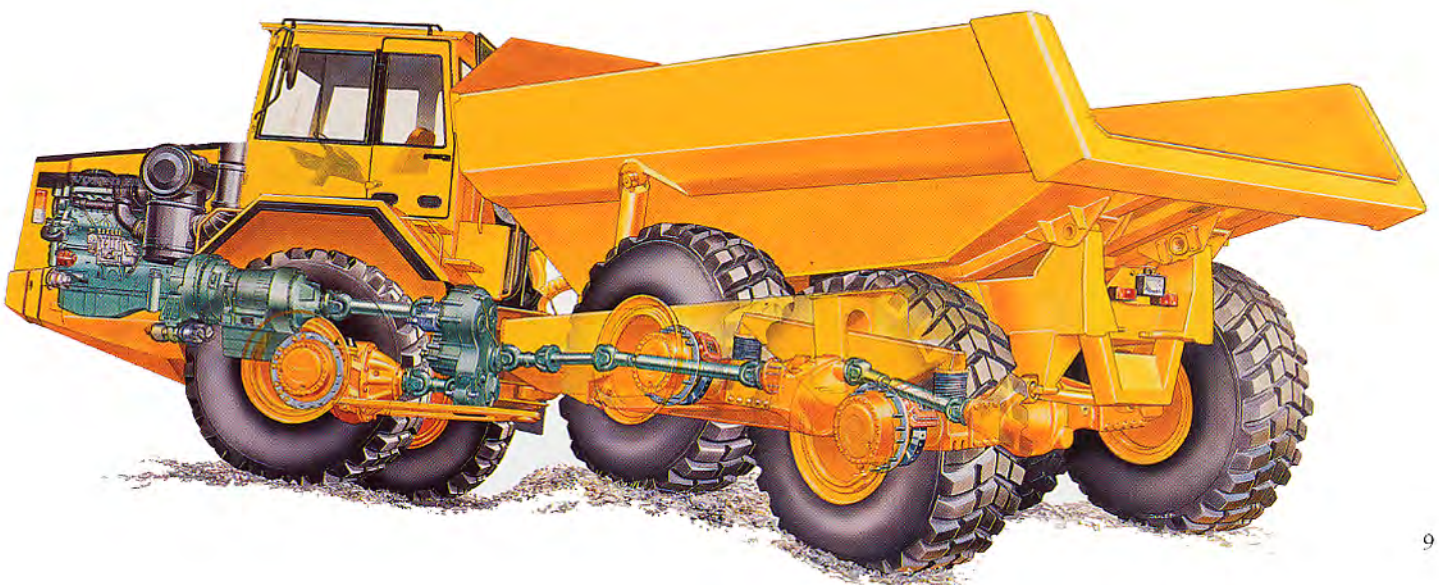
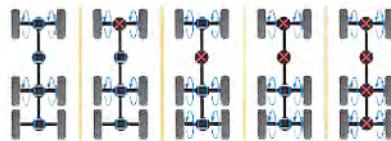

Genuine Volvo diesel engines

Volvo's in-line six-cylinder direct-injected four-stroke diesel engines with turbocharger and inter-cooler are the choice for all models. An excellent basic design providing high power outputs, high torques, low emissions and long life.

The engines have displacements of 7, 10 and 12 litres and have been completely adapted to the requirements of an articulated hauler. The torque is high even at low engine speeds for quick acceleration response, which is particularly important in difficult off-road conditions. Within the engine's normal working range, the torque increases when the engine speed decreases. This boosts the tractive force when the hauler meets resistance, for example on an uphill grade. Maximum rpm is relatively low, which leads to lower fuel consumption, less noise and longer life.

Turbocharging with intercooler provides efficient combustion with high power and low emissions. Cooling is very efficient with a hydraulically powered and thermostat-controlled radiator fan, with low power losses for the engine.

In the environment in which articulated haulers are normally used, efficient air filters are a must. Here there is also a second-stage filter that goes into action in emergencies and a warning lamp that tells the operator of the clogged filter.

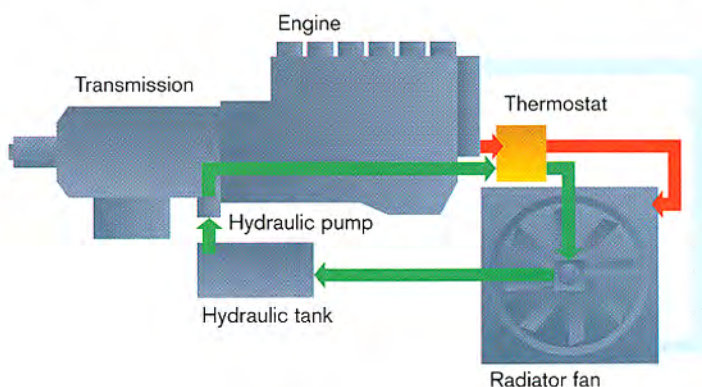
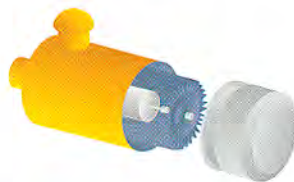
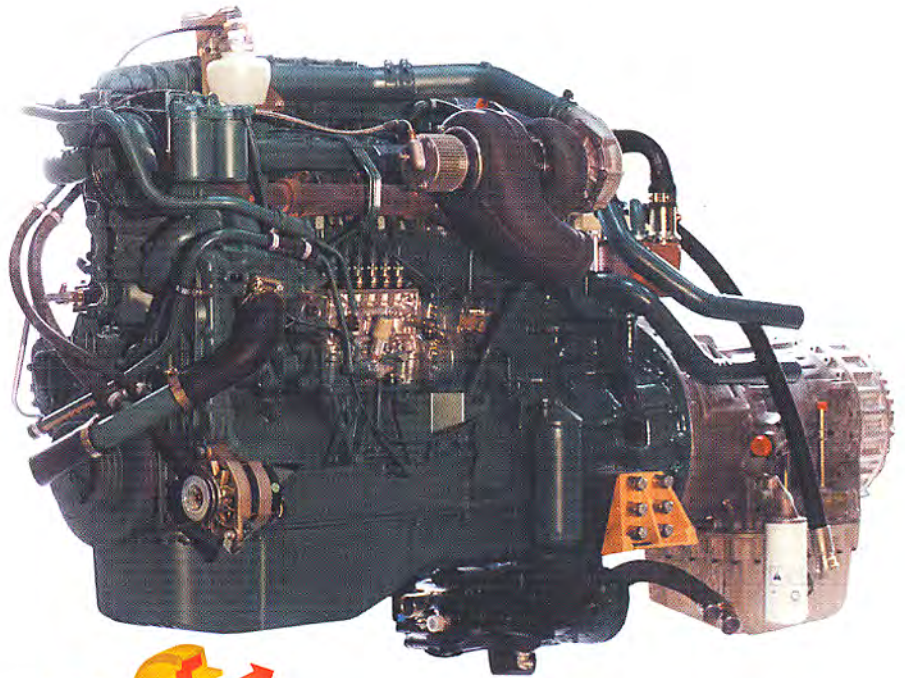

Torque curve

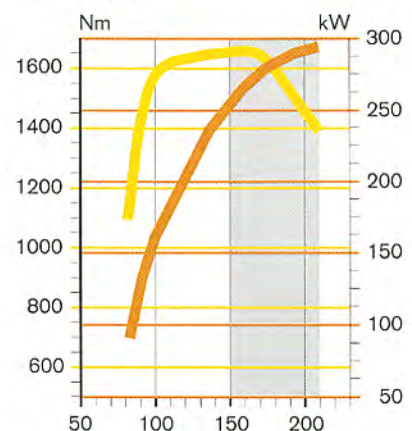

The force in the engine is made available when it is best needed, during starting and when the machine meets resistance. If the engine is operated within its working range, the torque increases when the rpm decreases, providing a needed boost on uphill grades and off the road.

Efficient brakes and wear-proof retarder

Volvo articulated haulers have an ability to get just about anywhere they're going - for example up and down steep hills, which makes great demands on brake capacity. Disc brakes or, on the A40, oil-cooled, wet disc brakes offer high capacity and safety. In combination with the hydraulic retarder, the brakes are also long-lived. The retarder is integrated in the transmission and is used to reduce or maintain constant speed on downhill grades. The braking effort can be infinitely varied, and since the retarder is hydraulic it virtually never wears out.

Tyres with low ground pressure

The tyres on the modern articulated hauler exert very low ground pressure, which is important at loading and dumping sites. The normal tyres have an 80 profile and a tread

pattern that makes them suitable both off the road and on the road. For particularly difficult conditions, when extra-low ground pressure is needed, there are tyres with a 65 profile in certain sizes, as well as extra-tough tyres for stony terrain.

Body and tipping

The body with large tipping angle and short tipping times enhances productivity. Being able to dump at exactly the right place quickly and easily is very important. The body is very sturdy and strong and prepared for exhaust gas heating. This reduces the risk that the load will freeze or get stuck.

Tipping takes about 15 seconds with a full load, and the body can be tipped to an angle of 70 degrees. Furthermore, the body dumps the load free of the machine, making it possible to put the load exactly where you want it, even directly over an edge, without the aid of other machines.



Accessories and equipment for even higher efficiency

Volvo articulated haulers are eminently well-equipped in their standard version for most applications. But for those who have special requirements or work in a severe climate or other special conditions, there is a rich variety of equipment and accessories. We show the most popular ones here – the complete range is even broader.

Contronic – the key to better economy

Volvo Contronic maintains a watchful eye over your hauler. Contronic monitors and protects the engine, drivetrain and brakes. It keeps track of service needs and reduces the risk of unscheduled stoppages.

Contronic can also furnish information on machine operation. It records distance travelled, running time and

number of cycles since the last resetting – information which helps you keep track of the work done. A detailed cab display gives the operator information on, among other things, running time, distance travelled, time to next service and much more.

Higher comfort

Air conditioning makes the cab pleasantly cool on hot days. The system is efficient, reliable and uses CFC-free refrigerant. The air-sprung operator's seat is perfect for driving on uneven terrain and the electrically heated rear-view mirrors provide added safety during work in damp and cold weather.

Filters for dusty conditions

During work in extremely dusty conditions, extra filtration of the intake air may be necessary. An oil bath filter with very high capacity is available as an accessory, as well as a coolant filter. An extra fuel filter is used when the fuel is of doubtful quality.

Modification of the body

Certain types of loads or loading methods require modification of the body on the articulated hauler. A spill guard at the front edge of the body protects the cab and the operator, a wire-operated tailgate reduces the risk of spillage during haulage. Heating of the bottom of the body greatly reduces the risk that the load will stick under certain operating conditions. The exhaust gases are used for body heating, which means no extra energy is consumed.



Operator in the centre – literally

The operator is without doubt one of the most important components in an efficient articulated hauler. An ergonomical, safe and comfortable operator's environment makes it simple to operate the hauler at a high level of efficiency.

The operator sits straight above the front axle, midway between the wheels. This puts him at the mid-point of the machine, where the cab's movements are minimal. Visibility all around is excellent, steering is precise and the automatic transmission saves more than 150 shifts every hour. Engagement and disengagement of the diff-locks and driving wheels is performed logically via ergonomically correct controls.

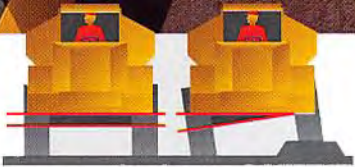

The entire range – six models from 20 to 40 tonnes

Volvo A20C 6x6 Small, agile, six-wheel drive.

Agility and flexibility make the Volvo A20C a highly useful articulated hauler. The perfect alternative for small jobs, stationary installations and other occasions when maximum load capacity isn't required.

TD 73 KFE

Net output SAE J1349

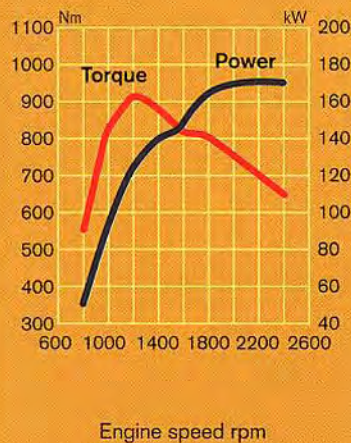

Technical data, Volvo A20C

Engine	Volvo TD 73 KFE
Displacement	6.73 l
Max. power	
SAE J1349 Gross	173 kW (235 hp) at 40 r/s (2400 r/min)
SAE J1349 Net	170 kW (231 hp) at 40 r/s (2400 r/min)
Max. torque	
SAE J1349 Gross	920 Nm at 20 r/s (1200 r/min)
SAE J1349 Net	910 Nm at 20 r/s (1200 r/min)
Top speed	47 km/h
Volume	
SAE 2:1 struck	9.4 m ³
SAE 2:1 heaped	12.0 m ³
Payload capacity	20,000 kg
Weight	
Net weight	16,400 kg
Gross weight	36,400 kg
Dimensions	
Overall length	9505 mm
Max. width	2490 mm
Max. height	3225 mm
Tyres	20.5 R 25



Volvo A25C 4x4

The perfect machine for stationary and under ground jobs.

The four-wheeled Volvo A25C is the perfect alternative for stationary jobs and under ground. It is used in its standard version in a great many mines and tunnels. With low-emission engine and turnaround wheels (which can turn around in only 9.5 m) it is practical even for very demanding jobs and cramped work-sites.

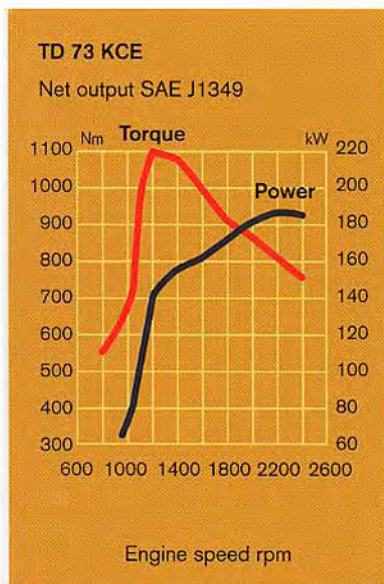

Technical data, Volvo A25C, 4x4

Engine	Volvo TD 73 KCE
Displacement	6.73 l
Max. power	
SAE J1349 Gross	190 kW (258 hp) vid 40 r/s (2400 r/min)
SAE J1349 Net	187 kW (251 hp) vid 40 r/s (2400 r/min)
Max. torque	
SAE J1349 Gross	1090 Nm vid 20 r/s (1200 r/min)
SAE J1349 Net	1080 Nm vid 20 r/s (1200 r/min)
Top speed	52 km/h
Volume	
SAE 2:1 struck	10.6 m ³
SAE 2:1 heaped	13.0 m ³
Payload capacity	22,500 kg
Weight	
Net weight	15,770 kg
Gross weight	38,270 kg
Dimensions	
Overall length	8955 mm
Max. width	3180 mm
Max. height	3285 mm
Tyres	
Front	23.5 R 25
Rear	29.5 R 25



Volvo A25C_{6x6}

The world's most common articulated hauler and the base for many special machines.

The Volvo A25C is the world's best-selling articulated hauler. It is very flexible, has a high haulage capacity and is easy to move from one worksite to another. The A25C is also the base for most special machines.

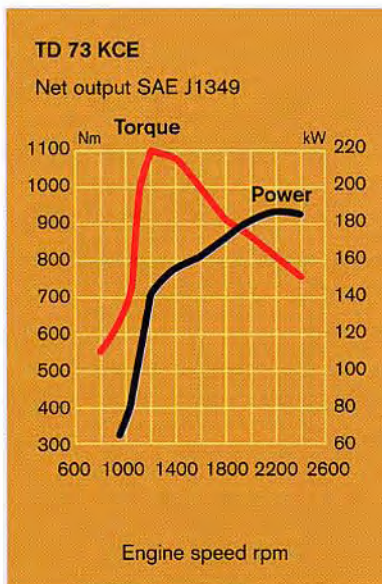

Technical data, Volvo A25C, 6x6

Engine	Volvo TD 73 KCE
Displacement	6.73 l
Max. power	
SAE J1349 Gross	190 kW (258 hp) at 40 r/s (2400 r/min)
SAE J1349 Net	187 kW (251 hp) at 40 r/s (2400 r/min)
Max. torque	
SAE J1349 Gross	1090 Nm at 20 r/s (1200 v/min)
SAE J1349 Net	1080 Nm at 20 r/s (1200 v/min)
Top speed	52 km/h
Volume	
SAE 2:1 struck	10.1 m ³
SAE 2:1 heaped	13.0 m ³
Payload capacity	22,500 kg
Weight	
Net weight	17,770 kg
Gross weight	40,270 kg
Dimensions	
Overall length	8955 mm
Max. width	3180 mm
Max. height	3285 mm
Tyres	23.5 R 25



Volvo A30C 6x6

An increasingly popular size choice.

With a powerful 10 litre Volvo diesel engine and 27 tonnes of payload, the Volvo A30C is a compact and highly productive machine. More and more contractors are choosing this size to get high capacity combined with relatively small overall dimensions.

TD 103 KBE
Net output SAE J1349

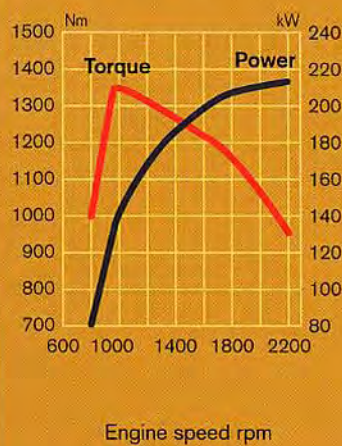

Technical data, Volvo A30C, 6x6

Engine	Volvo TD 103 KBE
Displacement	9.6 l
Max. power	
SAE J1349 Gross	216 kW (293 hp) at 36.7 r/s (2200 r/min)
SAE J1349 Net	213 kW (290 hp) at 36.7 r/s (2200 r/min)
Max vridmoment	
SAE J1349 Gross	1365 Nm vid 16.6 v/s (996 v/min)
SAE J1349 Net	1360 Nm vid 16.6 v/s (996 v/min)
Max. torque	52.3 km/h
Volume	
SAE 2:1 struck	12.9 m ³
SAE 2:1 heaped	16.5 m ³
Payload capacity	27,000 kg
Weight	
Net weight	21,500 kg
Gross weight	48,500 kg
Dimensions	
Overall length	10200 mm
Max. width	2980 mm
Max. height	3410 mm
Tyres	30/65 R 25



Volvo A35C 6x6

Powerful with 12 litre diesel engine.

With its 12 litre engine, the Volvo A35C is an extremely powerful machine that can handle the toughest jobs. It has a very high capacity and is comparable to bigger machines of other makes. These are features that make it very well suited for steep uphill climbs or extra-long haul distances.

TD 122 KAE

Net output SAE J1349



Technical data, Volvo A35C, 6x6

Engine	Volvo TD 122 KAE
Displacement	12 l
Max. power	
SAE J1349 Gross	245 kW (328 hp) at 35 r/s (2100 r/min)
SAE J1349 Net	240 kW (326 hp) at 35 r/s (2100 r/min)
Max. torque	
SAE J1349 Gross	1475 Nm vid 20 r/s (1200 r/min)
SAE J1349 Net	1470 Nm vid 20 r/s (1200 r/min)
Top speed	52.3 km/h
Volume	
SAE 2:1 struck	14.8 m ³
SAE 2:1 heaped	19.0 m ³
Payload capacity	32,000 kg
Weight	
Net weight	25,700 kg
Gross weight	57,700 kg
Dimensions	
Overall length	10898 mm
Max. width	3200 mm
Max. height	3604 mm
Tyres	26.5 R 25



Volvo A40 6x6

Biggest in the range,
very high productivity.

The Volvo A40 is the most productive articulated hauler that exists today. Despite its payload capacity it is manoeuvrable, easy to operate and has the same fine off-road characteristics as the other models. An extremely efficient machine for big jobs.

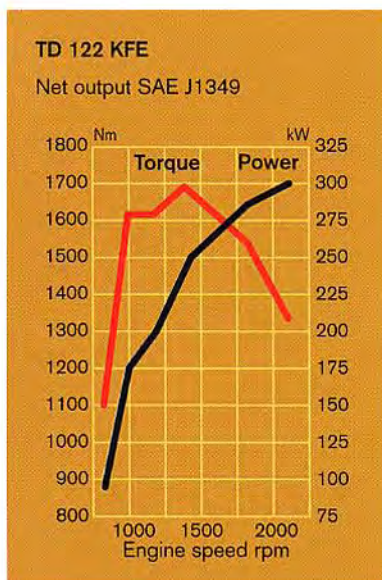

Technical data, Volvo A40, 6x6

Engine	Volvo TD 122 KFE
Displacement	12 l
Max. power	
SAE J1349 Gross	297 kW (404 hp) at 35 r/s (2100 r/min)
SAE J1349 Net	295 kW (401 hp) at 35 r/s (2100 r/min)
Max. torque	
SAE J1349 Gross	1675 Nm vid 23 r/s (1380 r/min)
SAE J1349 Net	1665 Nm vid 23 r/s (1380 r/min)
Top speed	52,6 km/h
Volume	
SAE 2:1 struck	16,3 m ³
SAE 2:1 heaped	22,0 m ³
Payload capacity	36.000 kg
Weight	
Net weight	30.150 kg
Gross weight	65.150 kg
Dimensions	
Overall length	11135 mm
Max. width	3430 mm
Max. height	3701 mm
Tyres	29.5 R 25



Special machines with all the advantages of the standard model

New types of special machines are introduced every year. They may be used for forestry, ammunition transport, garbage collection or as trailer-towing tractors. The advantages of building on a Volvo articulated hauler instead of custom-building a vehicle are many:

- the articulated hauler is very powerful and able to withstand huge stresses
- its off-road characteristics are better than those of most special vehicles
- the articulated hauler's reliability is documented
- service and parts are available all over the world
- the articulated hauler has the lowest possible haulage cost per tonne

The articulated hauler can perform many special duties with only minor modifications.

- Powerful and rugged
- All-terrain
- Reliable
- Simple service and maintenance
- Low costs

Volvo A25C equipped with container which hauls relatively light garbage. With its light ground pressure, off-road mobility and manoeuvrability, it can negotiate on the landfill and dump the garbage at the right place.



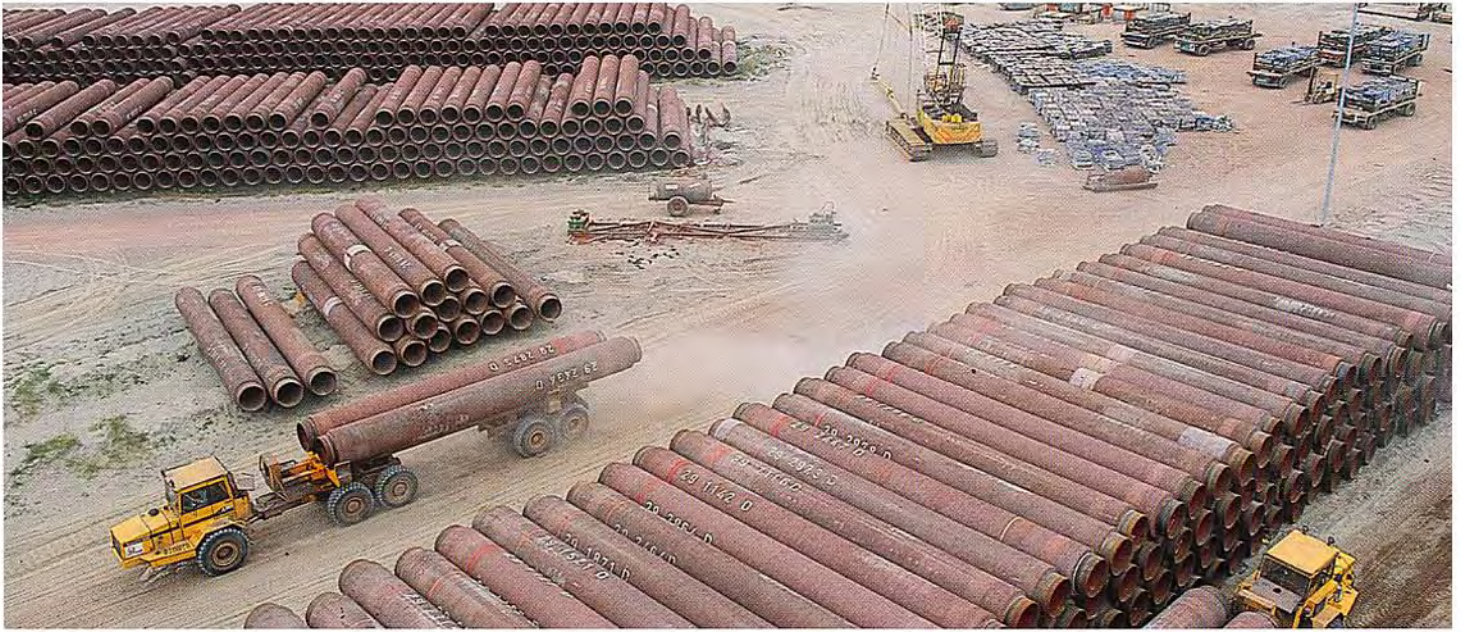

In the forestry and steel industries, Volvo's articulated haulers are ideally suited for load handling systems or as tractors for train weights of up to 100 tonnes.



*Multi-Purpose Vehicle
Built on the chassis for the
Volvo A25C, this is a very
versatile vehicle equipped
with a 24 tonne-metre crane
which carries a payload of
19 tonnes. It is mainly in-
tended for military ammuni-
tion and supply transport,
but is also well-suited for
civilian transport duties.*

Simple maintenance, qualified service

Volvo's articulated haulers are very reliable with a minimum need of maintenance. Serviceability is built in from the start and the operator has access to detailed instructions – the daily checkup routine includes only 6–8 lube points. The engine hood opens to a 90 degree angle, the radiator can be swung out and the belly plates can be opened. These are details that make maintenance simple – an important reason for the hauler's high reliability.

To each according to its needs

Preventive maintenance is tailored to each hauler's needs. Type of work, working environment, operating hours etc. are factors that determine the programme drawn up by Volvo and the hauler owner. Together with Volvo Genuine spare parts and replacement components, preventive maintenance is the best guarantee of maximum availability and safety.

Reliable information – Contronic

Contronic is an electronic monitoring system which continuously monitors all the machine's main functions. Connected to the central warning system, Contronic immediately informs the operator of any malfunctions. The information is shown in plain text on a display and fault messages are supplemented with a flashing warning lamp.



Contronic also provides advance reminders of periodic services and makes quick and exact diagnoses of any problems. Such information makes it possible to minimize downtime and increase availability.

Data stored by Contronic comprises an important source of information for the service personnel and helps them to identify and remedy faults quickly.

5,000 mechanics per year

Another mechanic is trained by Volvo's global network of service schools every other hour, 24 hours a day, 365 days a year. All of Volvo's markets have a sufficiently high level of service preparedness to meet the needs on that market. Genuine spare parts are available thanks to advanced systems of information management and material control. All to squeeze the most possible production out of every hauler.

PROSIS – all the information the mechanic needs

PROSIS is Volvo Construction Equipment's system for service information stored on CD-ROM. All the service literature, all the spare parts lists needed for Volvo's articulated haulers are on two CDs. With his portable PC, the serviceman in the field can immediately get all the information he needs. And with updates at least four times a year, the information is always correct and up-to-date.

Volvo – complete material transport solutions

Volvo is the largest industrial group in the Nordic region, with operations and sales all over the world. The focus is on the automotive sector with passenger cars, trucks, buses and construction vehicles. The company is also active within the marine and industrial engine and aerospace engineering sectors.

The company within the Volvo Group that is responsible for construction machines is Volvo Construction Equipment, VCE – one of the world's leading manufacturers of wheel loaders, excavators, and rigid and articulated haulers.

Volvo Articulated Haulers AB is a world leader in articulated haulers with more than 50 percent of the world market. The head office is in Växjö, and manufacturing takes place at factories in Sweden, the USA and Brazil.

Volvo excavators are the perfect partners for articulated haulers.

Volvo wheel loaders are available in a variety of models for all types of jobs. On many assignments they can be suitable as loaders for the articulated hauler.

Volvo Truck corporation is one of the world's largest manufacturers of trucks. Everything from long-haul trucks and construction trucks to large trailer-towing tractors and timber trucks.

Volvo Penta delivers engines and drive systems for marine and industrial applications. Generator units and engines for pumps are common on construction sites all over the world.

Euclid/Hitachi rigid haulers are big and powerful machines for use in mines, quarries etc.



Technology on human terms

When you choose products from Volvo Construction Equipment, you get not only high productivity and availability, but also the security and continuity for which the Volvo name stands. The machines are built with consideration for both man and the environment, and the breadth of the product range always enables you to choose the most efficient machine combinations. Your security as a customer lies not only in Volvo's service and spare parts organization, but also in the company's research and product development, which gives you access to cutting-edge technology. This ensures that your machine will live up to high standards of performance in demanding applications for a long time.

Volvo Construction Equipment includes the brands Volvo, Euclid, Zettelmeyer, Pel-Job and Mecalac.

VOLVO

**Volvo Construction
Equipment**