

VOLVO BM

5350 B

4x4



5350 B 4x4 - AGILE, HIGH-CAPACITY HAULER

The Volvo BM 5350 B 4x4 is a truly flexible transport machine that is particularly well suited where the layout of the job site imposes high demands on agility and good manoeuvrability.

Articulated steering, together with compact dimensions, make the 5350 B 4x4 easy to drive at high average speeds, even on confined work sites.

Where extremely good turnaround characteristics are required, in tunnels for example, the 5350 B 4x4 can be equipped with a special turnaround system. This represents an entirely new technique for effective manoeuvring of bulk haulage vehicles where the space is limited.

The Volvo BM 5350 B 4x4 also has superb off-road characteristics thanks to the large driving wheels. It easily negotiates difficult terrain and the good weight distribution allows it to be reserved confidently to the edge of the tipping area to dump load with precision. Particular attention has been devoted to the driver's station.

An outstanding suspension system, low noise levels and attention to ergonomic principles in the design and location of controls and levers ensure the best possible conditions for effective driver performance.

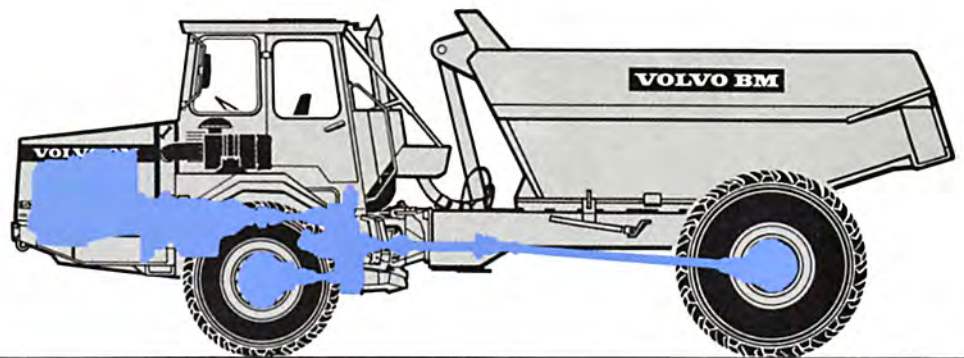

DRIVETRAIN

The power source in the 5350 B 4x4 is a 6-cylinder Volvo turbodiesel that develops 157 kW (213hp SAE). This is a modern, lightweight engine combining high power with low fuel consumption.



The drive train is composed of well-matched, Volvo-made components for long term reliability. Power is transmitted to the 4 driving wheels via an automatic gearbox.

Off-road mobility is guaranteed by the longitudinal differential lock and the transverse differential locks on both axles. The oversized rear wheels provide very high ground clearance.

Turnaround system (optional)

Volvo BM has developed a completely new turnaround system specially for the 5350 B 4x4. This consists of a wheelequipped bridge that is operated hydraulically from the cab. The operator can simply rotate the trailer unit a full 90° in less than 30 seconds.

This turning system makes the 5350 B 4x4 a highly effective vehicle for bulk haulage in confined spaces.

The turnaround system enables the 5350 B 4x4 to turn through 180° with ease in a width of only 9,5.

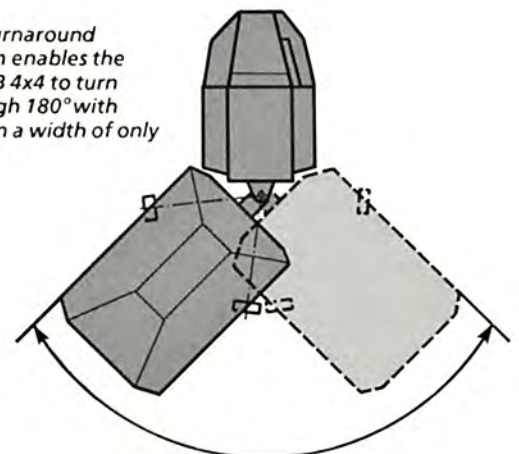

COMFORT AND SAFETY

Because the 5350 B 4X4 is designed for high-speed operation, the driver is comfortably seated, even during hard driving over bumpy surfaces. The cab is spacious with low noise levels and has well arranged controls and instrumentation for safe, effortless driving.

The cab is tested and ROPS-approved. The dual-circuit brake system has disc-brakes on all axles. This gives security during transports of big loads downhill.

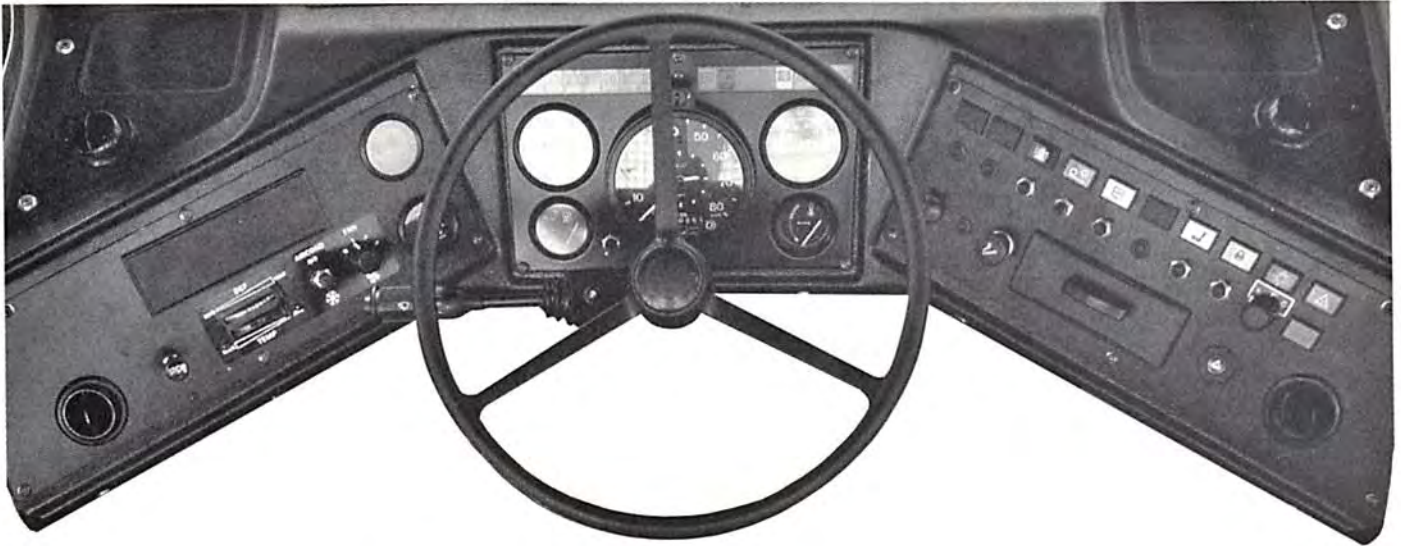

SUSPENSION

Tyres, rubber suspension with shock absorbers, rubber cab mounting and the sprung/damped driver's seat, all interact to give the 5350 B 4X4 excellent driving characteristics both on and off the road. This suspension is also completely maintenance-free.

SIMPLE SERVICE

Simple, fast servicing procedures give you more productive operating hours from the machine and your driver. There are only a few easily accessible lube points which need daily attention and the bonnet can be tilted forward, completely exposing the engine compartment for routine checks and maintenance.

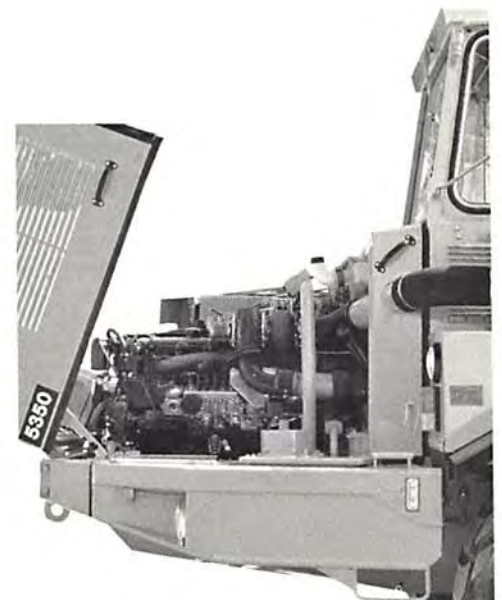



ENGINE

Volvo TD 71 GA: 6-cylinder-in-line direct-injected turbocharged 4-cycle diesel with overhead valves and wet replaceable cylinder linings.

Hydrostatic driven radiator fan with variable speed control, dependent on coolant temperature. Normally, the fan operates at 20 rps (1200 rpm), which gives 155 kW (210hp).

Max. power at		40 (2400)
SAE J 1349 Gross	kW (hp)	157 (213)
Flywheel power at	r/s (r/min)	40 (2400)
SAE J 1349 Net	kW (hp)	155 (210)
DIN 70020/6271	kW (hp)	140 (190)
Max. torque at	r/s (r/min)	30 (1800)
SAE J 1349	Nm (kpm)	710 (72,4)
DIN 70020/6271	Nm (kpm)	620 (63,3)
Displacement, total	dm ³ (in ³)	6,73 (411)
Bore	mm (in)	104,77 (4,125)
Stroke	mm (in)	130 (5,12)
Compression ratio		15,5:1



ELECTRICAL SYSTEM

Voltage	V	24
Battery capacity	Ah/No	135 / 2
Generator rating	W/A	1260 / 45
Starter motor power	kW (hp)	5 (6,8)



DRIVE TRAIN

Torque converter : single stage with free-wheeling stator and automatic lock-up.

Power-shift transmission, electronically controlled automatic gear-shifting.

Volvo BM dropbox of 2-stage design with power take-off and differential with 100 % lock-up.

All driving axles have differential locks. All axles are of Volvo BM make.

The driving axles have fully floating axle shafts with planetary gear type hub reduction.

Torque converter		2,4 : 1
Transmission		ZF 5 HP 500
Speeds		
Low gear, forward	1	km / h (mile / h) 6 (3,7)
	2	km / h (mile / h) 9 (5,6)
	3	km / h (mile / h) 15 (9,3)
	4	km / h (mile / h) 22 (13,7)
	5	km / h (mile / h) 31 (19,3)
Low gear, reverse	1	km / h (mile / h) 7 (4,3)
High gear, forward	1	km / h (mile / h) 9 (5,6)
	2	km / h (mile / h) 15 (9,3)
	3	km / h (mile / h) 25 (15,5)
	4	km / h (mile / h) 36 (22,4)
	5	km / h (mile / h) 51 (31,2)
High gear, reverse	1	km / h (mile / h) 11 (6,8)
Dropbox		VBM FL 652
Front axle, type		AH 54 E
Rear axle, type		AH 71 B
Tyres, front		23,5 R 25*
Tyres, bogie		29,5 R 25*



BRAKE SYSTEM

Dual-circuit system with air-hydraulic disc-brakes, designed to comply with ISO 3450.

Circuit division : one circuit for front axle and one for rear axle

The parking brake is a spring actuated brake on the propeller shaft, designed to hold a laden machine on a grade up to 18%.

The pneumatic system is driven by a gear driven compressor Retarder as optional equipment.



STEERING SYSTEM

Hydromechanical articulated steering. Emergency steering function as standard. Complies with ISO 5010. Two double-acting cylinders. 3,4 lock-to-lock turns



SUSPENSION VOLVO BM SUSPENSION SYSTEM

Front axle: Two rubber springs with bottoming absorption on either side. Stabilizer. Two shock-absorbers on either side.



CAB

Volvo BM cab, tested and approved in accordance with ROPS and the impact test method. Meets requirements for trucks, tractors and construction machines.

The cab is mounted on rubber pads, which contributes towards low vibration sensations.

Filtered air and pressurized cab. Driver's seat with flameproof upholstery. Extra seat for passenger.

Overhead guard FOPS available as optional equipment.

Number of exits (includes door)		3
Internal noise level	dB (A)	77



HYDRAULIC SYSTEM

Engine-dependent variable piston pumps mounted on flywheel power take-offs. Three of four take-offs are used.

One ground-dependent piston pump for emergency steering mounted on the dropbox.

Filtration of oil through 2 paper and magnet filters.

* = pump 1,2,3

** = ground-dependent hydraulic pump

Pump capacity	dm ³ (l) /min	100* / 118**
	(US gal /min)	(26,4* / 31,2**)
at	r /s (r /min)	40 (2400)
Working pressure	MPa (lbf /in ²)	18,5 (2680)*
	MPa (lbf /in ²)	18,5 (2680)**



TIPPING MECHANISM AND BODY

One 4-stage-tipping cylinder with the two top stages double-acting. Tipping stop built into the tipping cylinder.

Body made of hardened-and-tempered steel with particularly high impact strength.

Tipping angle	°	65
Tipping time with load	s	12
Lowering time	s	13
Body, plate thickness		
front/sides	mm (in)	6 (0,24)
bottom/chute	mm (in)	10 (0,39)
Yield strength	kp /mm ²	110
Tensile strength	kp /mm ²	130
Hardness min.	HB	360-440



LOAD CAPACITY

Body volumes according to SAE 2.1:

In the case of bodies with struck volumes of less than 10 m³ (13 yd³), heaped volume is given to the nearest half m³.

In the case of bodies with struck volumes of 10 m³ (13 yd³) or more, heaped volume is given to the nearest whole m³.

Struck volume is given in m³ (yd³) to one decimal place.

*) Weight increase is given for body with wear plates.

Load capacity	kg (sh tons)	22500 (25)
Body, struck	m ³ (yd ³)	10,1 (14,4)
	heaped	m ³ (yd ³)
With hydraulically operated tailgate	m ³ (yd ³)	14,0 (18,3)



WEIGHTS

Service weight includes body with wear plates, oil, fuel and water.

Service weight			
Front	kg (lb)	8850 (19510)	
Rear	kg (lb)	6450 (14220)	
Total	kg (lb)	15300 (32510)	
Payload			
Front	kg (lb)	3400 (7500)	
Rear	kg (lb)	19100 (42115)	
Total	kg (lb)	22500 (49610)	
Total weight			
Front	kg (lb)	12250 (27010)	
Rear	kg (lb)	25550 (56340)	
Total	kg (lb)	37800 (82120)	



GROUND PRESSURE

At 15% slump of unladen diameter and specified weights. Cone penetrometer value at depth of 250 mm (9,8 in).

Unladen			
Front	kPa (kp/cm ²)	95 (0,97)	
Rear	kPa (kp/cm ²)	48 (0,48)	
Laden			
Front	kPa (kp/cm ²)	131 (1,34)	
Rear	kPa (kp/cm ²)	191 (1,95)	
Cone penetrometer value		73	



SERVICE REFILL CAPACITIES

Crankcase volume	dm ³ (l) (US gal)	18,5 (4,9)
at change	dm ³ (l) (US gal)	16 (4,2)
Fuel tank	dm ³ (l) (US gal)	280 (74)
Cooling system	dm ³ (l) (US gal)	30 (7,9)
Transmission total	dm ³ (l) (US gal)	23 (6,1)
Dropbox	dm ³ (l) (US gal)	6 (1,6)
Front axle	dm ³ (l) (US gal)	35 (9,2)
Rear axle	dm ³ (l) (US gal)	47 (12,4)
Hydraulic system	dm ³ (l) (US gal)	160 (42,2)
Hydraulic tank	dm ³ (l) (US gal)	135 (35,6)

OPERATING DATA 5350B 4x4

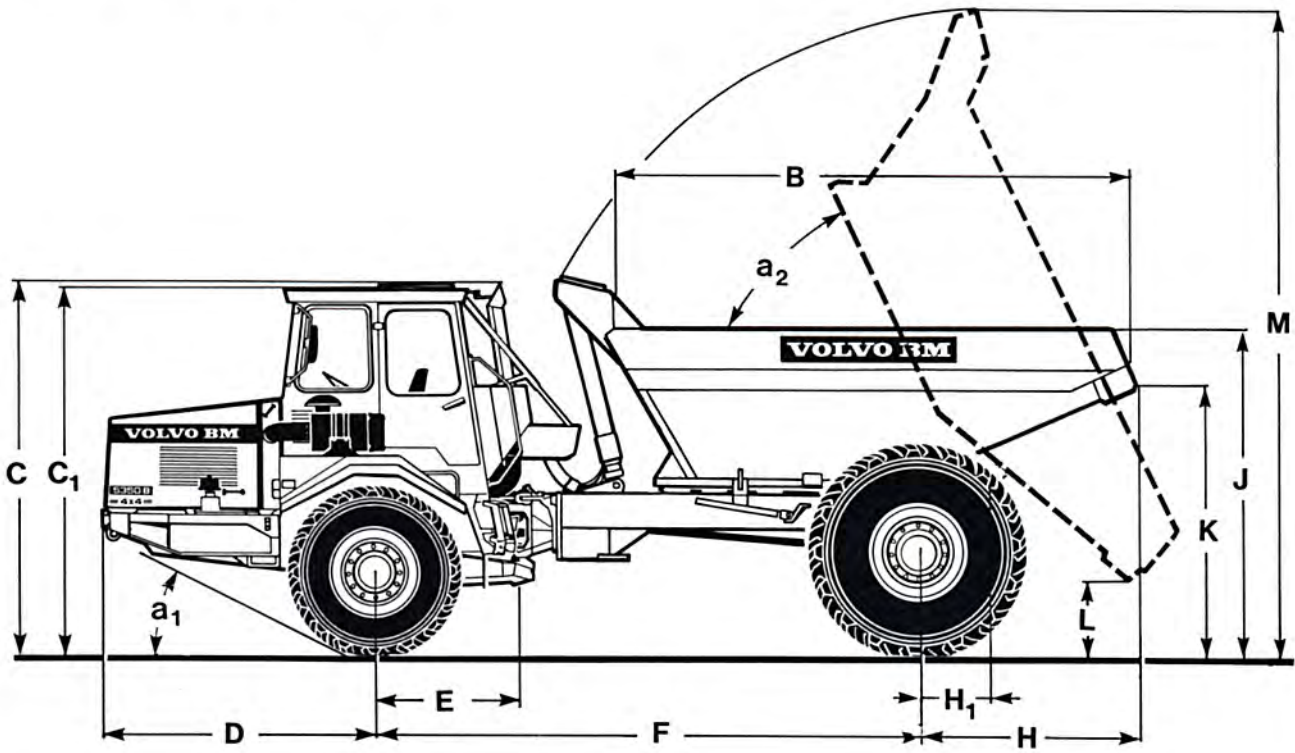

* = unladen machine

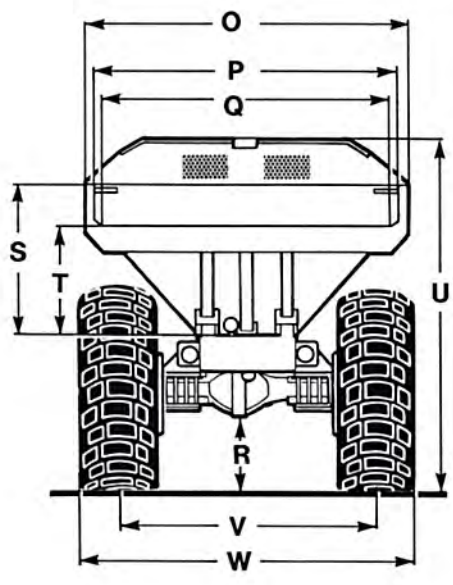
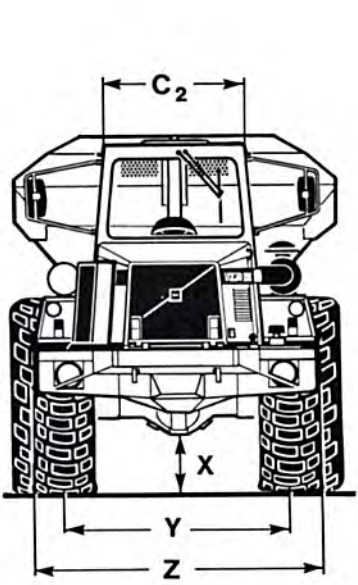

A	mm (ft in)	8955 (29'5")
A ₁	mm (ft in)	4495 (14'9")
A ₂	mm (ft in)	4985 (16'4")
B	mm (ft in)	4500 (14'9")
C	mm (ft in)	3200 (10'6")
C*	mm (ft in)	3240 (10'8")
C ₁	mm (ft in)	3150 (10'4")
C ₁ *	mm (ft in)	3190 (10'6")
C ₂	mm (ft in)	1320 (4'4")
D	mm (ft in)	2415 (7'11")
E	mm (ft in)	1200 (3'11")
F	mm (ft in)	4650 (15'3")
H	mm (ft in)	1890 (6'2")
H ₁	mm (ft in)	590 (2'1")
J	mm (ft in)	2730 (8'11")
J*	mm (ft in)	2810 (9'3")
K	mm (ft in)	2355 (7'11")
K*	mm (ft in)	2435 (8')
L*	mm (ft in)	705 (2'4")
M*	mm (ft in)	5610 (18'5")
N	mm (ft in)	7500 (24'7")
N ₁	mm (ft in)	3550 (11'8")
O	mm (ft in)	2980 (9'9")
P	mm (ft in)	2800 (9'2")
Q	mm (ft in)	2680 (8'10")
R	mm (ft in)	555 (1'10")
R*	mm (ft in)	635 (2'1")
S	mm (ft in)	1405 (4'7")
T	mm (ft in)	1030 (3'5")
U	mm (ft in)	3165 (10'5")
U*	mm (ft in)	3245 (10'8")
V	mm (ft in)	2370 (7'9")
V	mm (ft in)	3180 (10'5")
X	mm (ft in)	450 (1'6")
X*	mm (ft in)	465 (1'6")
Y	mm (ft in)	2150 (7'1")
Z	mm (ft in)	2795 (9'2")
a ¹	°	26
a ²	°	65
a ³	°	45

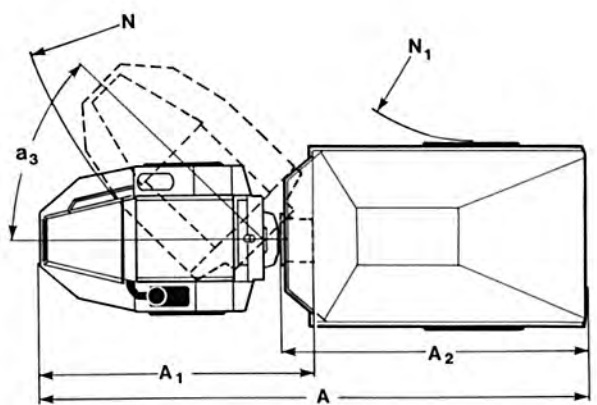

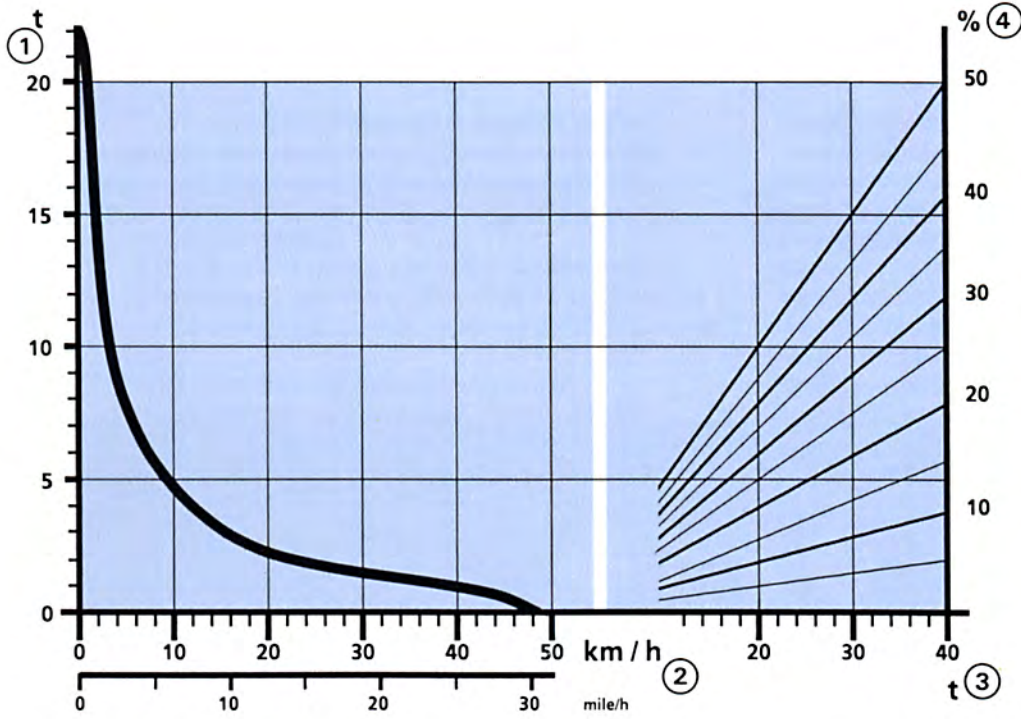

RIMPULL

*Rimpull graph based on practically measured values
Gross vehicle weight and ground slope + rolling resistance
gives rimpull requirement and speed.*

- 1 Rimpull in tons
- 2 Speed in km /h and miles /h
- 3 Gross vehicle weight in tons
- 4 Rolling resistance + grade resistance in %

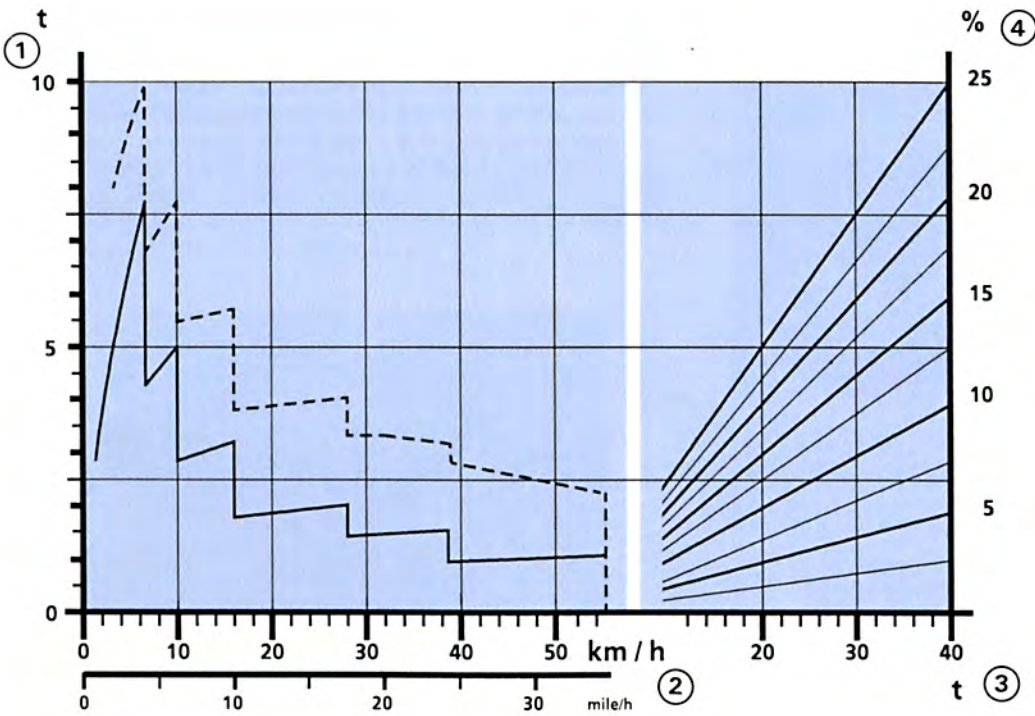

RETARDATION

*Dashed line shows retarder, exhaust brake, engine brake,
lock-up
Solid line shows exhaust brake, engine brake, lock-up*

- 1 Braking effort in tons
- 2 Speed in km /h and miles /h
- 3 Gross vehicle weight in tons
- 4 Rolling resistance - grade resistance in %

STANDARD EQUIPMENT

Safety and comfort

ROPS cab
Cab heater with filtered fresh air and defroster
Ergonomically designed and adjustable driver's seat
Windshield wipers
Windshield washers
Rear-view mirrors
Sun visor
Attachment points for seat belt
Cigarette lighter
Ashtray
Horn
Complete tyre inflation unit
Protective grille for rear window
Hazard flashers
Cab roof hatch
Tinted glass
Lights:
headlights
main/dipped/asym.
parking lights
reverse lights

direction indicators
side marker lights
brake lights
cab lighting
instrument lighting
Tool box
Steering joint locking assembly
Engine and electrical system
Turbocompressor
Alternator
Preheating
Ground-dependent steering-pump
Battery disconnect switch
Electrical outlet
Indicator for air cleaner
Gauges for:
brake pressure
fuel
engine temperature
revolutions and hours
Pilot lamps for:
battery charging
main beam
direction indicators

Warning lamps for:
low hydraulic oil level
steering function
engine-dependent pump
brake fluid level
low brake pressure
parking brake
engine oil pressure
transmission temperature
air filter
engine overspeed
Central warning:
hydraulic oil level
steering function
brake fluid level
brake pressure
radiator coolant level
engine oil pressure
engine overspeed
air filter
battery charging
transmission temperature

Drivetrain

Torque converter
Automatic gear-shifting
Dropbox with high/low gear
Automatic lock-up
Longitudinal differential lock
Differential lock, front axle
Differential lock, rear axle

Body

Body with wear plates and exhaust gas ducts

Tyres

Front : Rear
23,5 R 25* : 29,5 R 25*

OPTIONAL EQUIPMENT *(Standard on certain markets)*

Service and maintenance

Tool kit

Engine

Extra fuel filter
Oil-bath air cleaner

Electrical equipment

Rotating beacon with collapsible mount
Working lights
Electrically heated rear-view mirrors
Automatic cut-outs

Drivetrain

Retarder
Lock-up valve

Cab equipment

Seat belt
Passenger seat
Heated driver's seat
Speedometer
Air conditioning

External equipment

Fender step with work platform
Headlight washers
Wheel chocks
Mudguard wideners, front, 2,7 m
Towing schackle

Protection equipment

Collision guard
Overhead guard, FOPS

Body equipment

Tailgate

Other equipment

Turnaround system
Exhaust gas cleaning
TBG-equipment
SMV-symbol
Air horns
Rear-view mirrors (EEC)

Under our policy of continual product improvement, we reserve the right to change specifications and design without prior notice. The illustrations do not necessarily show the standard version of the machine.

Volvo BM Company

S-63185 ESKILSTUNA SWEDEN

