

16,7 – 19,1 t, 118 hp

**VOLVO EXCAVATOR**

# EC160C



**MORE CARE. BUILT IN.**



# VOLVO - A PARTNER TO TRUST.

Your machine and your word. The two things that matter most to the growth of your success. Trust the Volvo EC160C Excavator to help you keep both working for you. And because you can rely on Volvo uptime, you can keep moving – on to the next job. Its versatility is ideal for small-scale contractors or owner/operators. Perfect for general drainage, landscaping, footings and road maintenance, the Volvo EC160C is ready to be your partner. And with proven, industry-leading fuel economy and an enhanced Volvo Care Cab – this trusted partner will help you pay the bills everyday.

## **Your local partner around the globe**

Since 1927, Volvo has earned a global reputation for providing complete solutions. Volvo is built on core values of quality, safety and environmental care. The extensive line of construction equipment is augmented by Volvo's commercial transport solutions, including buses and trucks. This global experience and expertise have led to the ongoing development of engines with the lowest fuel consumption in their class. Today, the tradition continues with Volvo C-Series Excavators – designed and built to the exacting standards that make each machine a trusted Volvo partner.

## **The protection of Volvo quality**

Test the competitors – then test the Volvo EC160C. The difference is obvious: Volvo builds more care and quality throughout – from the well-built cab details to the reinforced service doors to the rigid, long-life undercarriage.

If you have ever owned or operated a Volvo Wheel Loader, Articulated Hauler or any one of our full scope of global equipment offerings, you know that Volvo stands for quality, comfort and safety. You can trust the Volvo EC160C Excavator to be the partner you can rely on – year after year.

## **Volvo innovates comfort – again**

Volvo is known as an innovative leader in comfort. That's because Volvo listens to customers – and then intelligently uses technology and constant improvements to deliver. The EC160C carries on the tradition with a larger, more ergonomic work environment. Visibility is better. So are the seat, floor space and access to controls. Take command.

## **Better fuel economy: your edge**

Volvo is also known for fuel efficiency. Once again, Volvo doesn't rest on reputation and the EC160C is set to remain the industry leader that gets the most out of each tank. Volvo: your most fuel-efficient option

## **Ease into your application**

From digging foundations and pools, landscaping and stump removal to pipe laying, loading and trenching, the versatile Volvo EC160C Excavator makes your work easier.

## **Strength and endurance**

When you face brutal terrain and long workdays, it's nice to know your excavator is up to the challenge. The Volvo EC160C answers with proven booms and arms that have been designed and tested to live up to high Volvo standards. The Volvo EC160C Excavator will help you get the job done so you can move on to the next job – and the next pay check.



• Volvo: a sign of trust and quality.



• Intelligent command means greater profits.



• Reinforced boom/arm handles all the jobs.



• The perfect all-around machine gets it done.



• Efficient Volvo engine delivers high torque at very low RPMs.

- Reliable, reinforced boom and arm handles a variety of jobs with an ideal combination of capacity, reach and force.
- Volvo high-tech toughness puts you comfortably in command of greater profits.
- Powerful Volvo V-ACT engine delivers proven performance and industry-leading fuel efficiency through high torque at low revs.

## VOLVO'S ENGINE LEADERSHIP SPANS LAND, SEA, SKY AND SPACE

As the world's largest manufacturer of 9-to-18-liter diesel engines, Volvo has unmatched expertise designing power systems that move the world. Volvo engines for Volvo Construction Equipment, Volvo

Aero, Volvo Buses, Volvo Penta and Volvo Trucks define productivity and fuel economy. Our performance has been honed on land, over the sea, across the sky and into space. Leading research and development

keeps all Volvo Group products at the forefront of productivity. So when we say Volvo engines are tested — and proven — you can believe it. Trust in it. It's the real advantage of Volvo Power.



# IN COMMAND WITH COMFORT AND SAFETY.

Consider the Volvo EC160C your new office. It's where you'll be most of the day. It's where you'll get your work done. And because it's a Volvo, it's as comfortable and safe as it is productive. The industry-leading Volvo cab has been further improved. Ease into the seat and see how the well-placed controls and instruments put you in command. There's more space and more glass with less noise and less vibration. And with enhanced Volvo safety and environmental protection, peace-of-mind comes standard. Get the edge you need. Go to work with the Volvo EC160C.

## **Comfortable new cab eases fatigue**

Volvo remains the innovative industry leader in comfort. The EC160C adjustable seat supports your whole body. Pedal positions are now shifted forward for more foot space. The cab is wider. Experience the right operating position with joystick and seat adjustments. To reduce fatigue and hazardous whole body vibration, Volvo has gone beyond emerging cab vibration regulations with an enhanced suspension system.

## **Greater visibility puts you in command**

The new cab features expansive glazed surface areas. Operators told Volvo that upper visibility is important. Volvo listened. The roof hatch offers an expanded view during high-reach applications. The engine hood size and height has been reduced for better visibility to the rear. The gas strut assisted windshield opens with ease, while the smartly positioned windshield wiper cleans a wider area – including both upper corners. The easy-to-read LCD color monitor offers real-time information. The EC160C Volvo engine produces less noise and the pressurized, well-insulated cab blocks sound. The Volvo experience means greater production.

## **Electronic climate control**

Intelligently going beyond automobile technology, the EC160C's high-tech electronic climate control system comforts your entire body with the highest-capacity heating and cooling ventilation system available in the excavator industry.

## **A safe place to work**

The new-design Volvo Care Cab, with operator protective structure provides security. Volvo's attention to ergonomics when designing controls and pedals ensures operator protection for safe, long-term use. An optional color rear view camera displaying on the LCD color monitor provides a safe view while slewing or travelling.

## **Anti-slip walk areas**

Outside the cab, all steps and platforms feature quality anti-slip traction with punched steel plates for superior grip – even when wet or icy. The bolt-on plates feature recessed bolts for less risk of trip hazard.

## **More care for the environment**

More than 95% of the machine materials are recyclable. External sound levels have been greatly reduced for fewer disturbances. The machine's exterior paint is lead-free. Safety – for the people and environment around you – has always been a cornerstone value of Volvo. You can trust Volvo to pay special attention to environmental protection.



• Experience the comfort of the suspension seat.



• Well-positioned monitor and controls.



• Greater floor space with ergonomic pedals.



• Industry's highest heating/cooling capacity with 14 vents.

- Expansive glass and clear sight lines provide outstanding all-around visibility with greater safety.
- Experience the adjustable, suspension seat and take command of the jobsite.
- All-new cab is larger and more comfortable with ergonomic controls and vibration dampening suspension – for all-day production.
- New, easy-to-read LCD color monitor and perfectly positioned controls put you in command.
- Expanded floor space and ergonomic travel pedals provide greater legroom and more room for work boots.
- Electronic climate control system distributes comfort evenly with 14 air vents and the highest-capacity heating/cooling available in the excavator industry.



# INTELLIGENT UPTIME TO GET MORE DONE.

The Volvo EC160C defines uptime in simple terms. Complete service access. Fast, easy routine maintenance. Long service intervals. Ground-level convenience. Add it all up and you've got the Volvo edge: a machine that works as hard as you – every day. And because increased production results in increased profit, the Volvo EC160C is ready for you. It's got plenty of power and ideal capacity for a wide range of jobs. Get in and go to work. Grading, piping, excavation, trenching and more. It's time to grow your business. It's time to get more done.

## **Powerful V-ACT Volvo engine**

For the strength behind all your jobs, the Volvo EC160C is equipped with a powerful new generation Stage IIIA compliant V-ACT (Volvo Advanced Combustion Technology) engine. It delivers 87 kW (118 hp) of optimized output. And with high engine torque at low revs, Volvo achieves ultra-efficient fuel consumption.

## **Commanding hydraulic flow**

The advanced hydraulic system is highly responsive, so it's easy to quickly get the job done. It's got the boom, arm and slew priority you need. And because of its precision, responsive control, you know exactly what to expect when you touch the joystick. In-cab operator-selectable hydraulic flow and pressure increases utility and ease of use with special attachments.

## **Quick fit versatility**

Volvo hydraulic quick fit solutions make changing attachments quick and easy – all from the comfort and safety of the cab. Two S-type Volvo quick fit models are available to fit new and existing customer's buckets/attachments. The new optional universal quick fit increases flexibility. Increased bucket speed, optional boom float position and a wide range of working modes gives you the perfect match for the application, attachment and terrain.

## **Service has been simplified**

Maximum uptime is aided by easy service – that's why Volvo has simplified it. Ground level access makes inspection and service quick and easy. Change the oil, fuel and water separator filters, as well as drain the oil and access the hydraulic pump – all from the ground. Inside the cab, quickly check the engine oil level and perform self-diagnostics through the LCD monitor.

## **Daily maintenance with ease**

The cab air filter is conveniently located outside the cab for easy replacement. Fuses are easy to check in a sealed, steel box behind the cab. The sloped track frame design allows for self-cleaning of mud and debris.

## **Intelligent hydraulic cooling system**

Fan speed is hydraulically (not engine) driven, intuitively sensing hydraulic oil/ engine temperature and automatically activating to keep the system regulated at an optimized temperature. O-ring faced sealing in all hydraulic connections add reliability. An anti-corrosive aluminium cooling module offers better heat dissipation and long life.

## **Common parts lower costs**

Volvo designs all its machines with a common vision. The Volvo EC160C uses over 100 components and consumable parts common to other Volvo machines you may run. This results in higher availability of parts and lower operating costs.





• Simplified, ground level service access.



• Easy access to hydraulic pumps and filters.



• Safe, anti-slip steps and platforms.



• More care built in.

- Intelligent, advanced hydraulic system balances available engine power with hydraulic output for smooth, responsive control.
- Simplified, ground level service access, long service intervals and centralized lubrication points means more uptime.
- Quick and easy access to hydraulic pumps and filters.
- Anti-slip, punched steel platforms and walk areas offer superior grip and safety.
- More uptime from well-protected hydraulic lines and easy-access grease points.

# DAY-IN, DAY-OUT ENDURANCE. EVERY YEAR.

There's enough on your mind. You don't want to have to wonder if your machine will start today or if your hydraulic pump can really handle the work during that upcoming big job. That's why the innovative Volvo EC160C is built with trusted Volvo quality through and through. While others may cut costs with cheap components, plastic parts or thin panels, Volvo puts reliability and enduring quality into all details. You can see and feel it. That means years from now you're not wondering about your Volvo, you're working and making money.

## **More quality built in**

Walk around the EC160C. Climb in the cab. The quality isn't hard to find. There's rigid service doors, a sturdy engine hood and a protected electrical system. From the strengthened, high-tensile steel undercarriage frame and reinforced superstructure with double-welded corners to the heavy-duty booms and arms – it's built for reliability along with lower costs and high resale value.

## **Trust the strength of the track**

The Volvo EC160C undercarriage and track are built for durability, reliability and stability. The lifetime greased sealed track link prevents grease leaks, reduces noise and guarantees longevity.

## **Intelligent, tough, high-tech**

The Volvo EC160C blends intelligence and toughness in innovative new ways. And even though it's high-tech, it's easy to learn and operate. The machine's computer balances maximum available horsepower to hydraulic output, preventing engine overload – regardless of load on the pumps or engine speed. Volvo can do this because it's a Volvo engine, designed by Volvo engineers to specifically work with Volvo components.

## **Rely on your Volvo dealer for the support services you need:**

### **CareTrack monitors it all**

CareTrack is an optional GPS monitoring program that works with the machine's diagnostic system. Installation is simple. Track geographic machine location, usage, fuel consumption and more from your computer. Maximize uptime through important service reminders. CareTrack also offers theft protection by allowing you to limit geographic areas or hours of the day the machine can be operated.

### **MATRIS reports on your efficiency**

MATRIS delivers detailed operating history analysis about the utilization and efficiency factors that influence your operating costs. MATRIS turns the data captured inside the machine's computer into easy-to-use graphs and reports. Maximize machine and operator performance, while reducing maintenance costs and increasing service life.

### **PROSIS makes parts ordering faster**

PROSIS is a CD-ROM application that makes it quick and easy for your Volvo dealer to order all your Volvo CE product parts. Your dealer will help you find the right part, place your order and get you back up and running fast.





- Lifetime greased and sealed track link ensures long life.
- Rely on the quality for a wide variety of jobs.
- Optional protected arm with longer, reinforced strip and replaceable steel plates at both ends offers less wear and cheaper arm end maintenance.
- Reinforced, robotically-welded undercarriage frame distributes stress with rigid strength.
- Durable, standard undercover on the underside of the x-shaped frame provides extra protection.



• Your trust. Your satisfaction. Count on it.



• Lifetime greased and sealed track link.



• Underside bolt protection endures tough conditions.



• Volvo is the partner you can grow with.

# YOUR OPTIONS ARE OPEN TO GREATER PROFITS.

Volvo is different from the rest. So are operators, applications and site conditions around the world. That's why Volvo helps keep everyone happy, comfortable and productive with optional equipment to suit individual needs. Extra protection, extra comfort or added strength can give you a big edge in performance and, most importantly, profits.

## **Hydraulic kits**

A wide variety of hydraulic kits are available for various boom and arm combinations. Each kit maximizes performance according to the machine's boom and arm length/shape. Get the most out of rotating/tilting attachments, crushers and hammers. Choose between 1 or 2 pump flow for best performance.

## **Hydraulic quick fit**

A Volvo hydraulic quick fit makes changing attachments quick and easy – all from the comfort and safety of the cab. Different quick fit types (universal and S-type) are available to fit new and existing customer's buckets/attachments.

## **Dozer blade**

A front-end dozer blade increases machine versatility in job applications such as backfilling trenches and site clean up. It can also be used to level the excavator when working on slopes.

## **Wrist control joysticks - proportional control**

Low-effort, wrist control joysticks provide smooth, precision control for increased comfort, efficiency and production. Wrist control joysticks with proportional control switches are also available.

## **Operator seats**

Volvo offers a wide variety of ergonomic operator seats designed specifically for comfort and protection. All seats, from various adjustable models to the most advanced air-suspended models, provide excellent support and are individually adjustable to suit operator preferences.

## **Diesel-driven engine coolant heater**

The diesel-driven engine coolant heater aids low temperature starting, while simultaneously warming the cab. Heating time duration can be adjusted, set and programmed in advance to engage at a specific date and time.

## **FOG and FOPS cab protection**

FOG (Falling Object Guard) and FOPS (Falling Object Protective Structure) certified cabs provide peace-of-mind for tough conditions such as quarries and demolition. The front guard of the FOG unit is tiltable and supported by a gas strut for easy front window cleaning.

## **Straight travel pedal**

A pedal located by the left foot rest operates both travel motors at the same time, providing convenience when traveling and efficient work control in applications such as pipe laying.

## **Rear view camera**

Inside the cab, the wide screen color LCD of the IECU (Instrument Electronic Control Unit) provides a safe rear view when reverse travel is selected or of the right hand side of the superstructure when the slew function is activated. The protected rear and side view cameras can be switched manually using the selection switch on the keypad.

**To customize your excavator with other optional equipment features to suit your application, contact your local Volvo dealer.**



# VOLVO OPTIONAL EQUIPMENT



**Hydraulic kits**  
**Hydraulic quick fit**  
**Dozer blade**

**Wrist control joysticks**  
**- proportional control**  
**Operator seats**  
**Diesel-driven engine**  
**coolant heater**

**FOG and FOPS cab protection**  
**Straight travel pedal**  
**Rear view camera**

**NOTE:** Some features listed as optional equipment are standard equipment in some markets. Some equipment features listed are not available in all markets. Not a complete list of available optional equipment features. See included specification sheet for a complete listing.

# WALKAROUND. LOOK AROUND. EXPERIENCE IT.

## MORE SAFETY

- **The new-design Volvo Care Cab**, with operator protective structure provides security.
- **Anti-slip steps and platforms** with punched steel plates for superior grip even when wet or icy.
- **Low engine emission levels and low noise.**
- **Reduced engine hood size/height** for better rear visibility.
- **Recessed bolts on superstructure** walk areas for less risk of trip hazard.
- **Lead-free exterior paint:** more harmony with the environment.

## MORE PROFIT

- **New generation Volvo V-ACT engine:** powerful, innovative and efficient.
- Volvo continues to deliver **industry-leading fuel efficiency.**
- **Advanced hydraulic system** with priority functions and optional boom float position.
- **Optional universal quick fit** makes versatility easier.

## MORE COMFORT

- **New larger, more comfortable cab** puts you in command with perfectly placed, ergonomic controls.
- **Roomy, adjustable seat** supports your whole body.



- **Top-mounted windshield wiper** cleans a wider area – including both upper corners.
- **Vibration dampening** protects against whole body fatigue for all-day production.
- **Electronic climate control system** delivers the highest-capacity heating and cooling available.



## MORE UPTIME

- **Simplified, ground level serviceability** means more uptime.
- **Easy access, centralized lubrication points.**
- **Easy-to-read LCD color monitor** for real-time information and trouble-shooting.
- **Easy to learn. Easy to operate. Easy to get more done.**

## MORE QUALITY

- **Strengthened undercarriage frame** provides endurance against daily abuse.
- **Reinforced boom/arm and proven components** deliver every time.
- **Reinforced superstructure** with double welded corners.
- **Lifetime greased sealed track link** prevents leaks and guarantees long life.

# SPECIFICATIONS

## Engine

The next-generation Volvo diesel engine uses Volvo Advanced Combustion Technology (V-ACT) to deliver lower emissions and maintain superior performance and fuel efficiency. The EU Stage IIIA compliant engine uses precise, high-pressure fuel injectors, turbo charger and air to air intercooler and electronic engine controls to optimize machine performance.

<b>Engine</b>	Volvo D6E EBE3
<b>Max. power, at</b>	30 r/s (1 800 r/min)
<b>Net (ISO 9249, SAE J1349)</b>	87 kW (118 hp)
<b>Gross (SAE J1995)</b>	98 kW (133 hp)
<b>Max. torque at 1 350 r/min</b>	625 Nm
<b>No. of cylinders</b>	6
<b>Displacement</b>	5,7 l
<b>Bore</b>	98 mm
<b>Stroke</b>	126 mm

## Electrical system

High-capacity electrical system that is well protected. Waterproof double-lock harness plugs are used to secure corrosion-free connections. The main relays and solenoid valves are shielded to prevent damage. The master switch is standard.

<b>Voltage</b>	24 V
<b>Batteries</b>	2 x 12 V
<b>Battery capacity</b>	140 Ah
<b>Alternator</b>	28 V / 80 A

## Service refill capacities

<b>Fuel tank</b>	250 l
<b>Hydraulic system, total</b>	265 l
<b>Hydraulic tank</b>	123 l
<b>Engine oil</b>	25 l
<b>Engine coolant</b>	24 l
<b>Slew reduction unit</b>	2,6 l
<b>Travel reduction unit</b>	2 x 5,8 l

## Slew system

The slew system uses an axial piston motor, driving a planetary gearbox for maximum torque. An automatic holding brake and anti-rebound valve are standard.

<b>Max. slew speed</b>	11,9 r/min
<b>Max. slew torque</b>	51,7 kNm

## Drive

Each track is powered by an automatic two-speed shift travel motor. Track brakes are multi-disc, spring-applied and hydraulically released. The travel motor, brake and planetary gears are well protected within the track frame.

<b>Max. drawbar pull</b>	145 kN
<b>Max. travel speed</b>	3,0/5,6 km/h
<b>Gradeability</b>	35°

## Undercarriage

The undercarriage has a robust X-shaped frame. Greased and sealed track chains are standard.

<b>Track pads</b>	2 x 44
<b>Link pitch</b>	190 mm
<b>Shoe width,</b> <b>triple grouser</b>	500/600/700/ 800/900 mm
<b>Bottom rollers</b>	2 x 7
<b>Top rollers</b>	2 x 2

## Hydraulic system

The hydraulic system, also known as the "Integrated work mode control" is designed for high-productivity, high-digging capacity, high-maneuvering precision and excellent fuel economy. The summation system, boom, arm and slew priority along with boom, arm and bucket regeneration provides optimum performance.

The following important functions are included in the system:

**Summation system:** Combines the flow of both hydraulic pumps to ensure quick cycle times and high productivity.

**Boom priority:** Gives priority to the boom operation for faster raising when loading or performing deep excavations.

**Arm priority:** Gives priority to the arm operation for faster cycle times in leveling and for increased bucket filling when digging.

**Slew priority:** Gives priority to slew functions for faster simultaneous operations.

**Regeneration system:** Prevents cavitation and provides flow to other movements during simultaneous operations for maximum productivity.

**Power boost:** All digging and lifting forces are increased.

**Holding valves:** Boom and arm holding valves prevent the digging equipment from creeping.

## Main pump:

Type: 2 x variable displacement axial piston pumps  
Maximum flow: 2 x 145 l/min

## Pilot pump:

Type: Gear pump  
Maximum flow: 18 l/min

## Hydraulic motors:

Travel: Variable displacement axial piston motor with mechanical brake  
Slew: Fixed displacement axial piston motor with mechanical brake

## Relief valve setting:

Implement	32,4/34,3 MPa
Travel circuit	34,3 MPa
Slew circuit	26,5 MPa
Pilot circuit	3,9 MPa

## Hydraulic cylinders:

Mono boom	2	Bore x Stroke	ø115 x 1 165 mm
1st boom of 2-piece boom	2	Bore x Stroke	ø115 x 1 165 mm
2nd boom of 2-piece boom	1	Bore x Stroke	ø160 x 950 mm
Arm	1	Bore x Stroke	ø120 x 1 345 mm
Bucket	1	Bore x Stroke	ø105 x 1 000 mm

## Cab

The new-design Volvo Care Cab, with operator protective structure provides security, along with more interior space, leg room and foot space. Audio system with remote control. 3 cup holders, 3 high-capacity outlets. Independently adjustable joystick consoles.

Excellent all around-visibility provided through maximum cab glass, transparent roof hatch and 2-piece sliding door window. The lift-up front windshield can easily be secured at the ceiling and the removable lower front glass can be stored in the side door. Interior lighting consists of one reading light and one cab light with timer.

The pressurized and filtered cab air is supplied by a 14-vent climate-control system, providing fast defrosting and high cooling and heating performance. Viscous/spring-mounted suspension cushions operator from vibrations.

Deluxe seat with adjustable height, tilt, recline, forward-back settings, retractable seat belt and selectable horizontal suspension for reduced whole body vibration.

Adjustable easy-to-read 16,3 cm (6,4") LCD color monitor provides real time information of machine functions, important diagnostic information and a wide variety of work tool settings. LCD monitor is switchable to rear view camera monitor (option).

## Sound Level:

**Sound level in cab according to ISO 6396**  
..... LpA 70 dB(A)

**External sound level according to ISO 6395 and EU Directive 2000/14/EC**  
..... LwA 101 dB(A)

## Ground pressure

- **EC160C L** with 5,2 m boom, 2,6 m arm, 690 l (470 kg) bucket, 2 750 kg counterweight

Description	Shoe width	Operating weight	Ground pressure	Overall width
Triple grouser	500 mm	16 800 kg	47,6 kPa	2 700 mm
	600 mm	17 000 kg	40,2 kPa	2 800 mm
	700 mm	17 300 kg	35,0 kPa	2 900 mm
	800 mm	17 700 kg	31,3 kPa	3 000 mm
	900 mm	17 900 kg	28,2 kPa	3 200 mm

- **EC160C L with dozer blade** with 5,2 m boom, 2,6 m arm, 690 l (470 kg) bucket, 2 750 kg counterweight

Description	Shoe width	Operating weight	Ground pressure	Overall width
Triple grouser	500 mm	18 000 kg	50,9 kPa	2 700 mm
	600 mm	18 200 kg	43,0 kPa	2 800 mm
	700 mm	18 400 kg	37,3 kPa	2 900 mm
	800 mm	18 800 kg	33,3 kPa	3 000 mm
	900 mm	19 100 kg	30,0 kPa	3 200 mm

- **EC160C NL** with 5,2 m boom, 2,6 m arm, 690 l (470 kg) bucket, 2 750 kg counterweight

Description	Shoe width	Operating weight	Ground pressure	Overall width
Triple grouser	500 mm	16 700 kg	47,2 kPa	2 490 mm
	600 mm	16 900 kg	39,9 kPa	2 590 mm
	700 mm	17 100 kg	35,3 kPa	2 690 mm
	800 mm	17 500 kg	31,4 kPa	2 790 mm
	900 mm	17 800 kg	28,4 kPa	2 990 mm

- **EC160C NL with dozer blade** with 5,2 m boom, 2,6 m arm, 690 l (470 kg) bucket, 2 750 kg counterweight

Description	Shoe width	Operating weight	Ground pressure	Overall width
Triple grouser	500 mm	17 800 kg	50,4 kPa	2 490 mm
	600 mm	18 000 kg	42,6 kPa	2 590 mm
	700 mm	18 300 kg	37,0 kPa	2 690 mm
	800 mm	18 700 kg	33,0 kPa	2 790 mm
	900 mm	18 900 kg	29,8 kPa	2 990 mm

## Max. permitted buckets

- Note: 1. Bucket size based on ISO 7451, heaped material with a 1:1 angle of repose.  
 2. "Max. permitted sizes" are for reference only and are not necessarily available from the factory.  
 3. Bucket widths are less than bucket's tip radius.

- **EC160C L** with 2 750 kg counterweight

Description	Max. bucket volume / weight	5,2 m boom, direct fit			5,2 m boom, S1 quick fit			5,2 m boom, S6 quick fit		
		2,3 m arm	2,6 m arm	3,0 m arm	2,3 m arm	2,6 m arm	3,0 m arm	2,3 m arm	2,6 m arm	3,0 m arm
GP bucket 1,5 t/m <sup>3</sup>	l / kg	1 225 / 1 000	1 025 / 850	850 / 700	1 125 / 950	950 / 800	750 / 600	1 150 / 950	975 / 800	775 / 650
GP bucket 1,8 t/m <sup>3</sup>	l / kg	1 075 / 900	900 / 750	750 / 600	1 000 / 850	825 / 700	675 / 550	1 025 / 850	850 / 700	700 / 550

- **EC160C NL** with 2 750 kg counterweight

Description	Max. bucket volume / weight	5,2 m boom, direct fit			5,2 m boom, S1 quick fit			5,2 m boom, S6 quick fit		
		2,3 m arm	2,6 m arm	3,0 m arm	2,3 m arm	2,6 m arm	3,0 m arm	2,3 m arm	2,6 m arm	3,0 m arm
GP bucket 1,5 t/m <sup>3</sup>	l / kg	1 125 / 950	1 025 / 850	850 / 700	1 025 / 850	950 / 800	750 / 600	1 050 / 900	975 / 800	775 / 650
GP bucket 1,8 t/m <sup>3</sup>	l / kg	1 000 / 850	900 / 750	750 / 600	900 / 750	825 / 700	675 / 550	925 / 800	850 / 700	700 / 550

## Dimensions

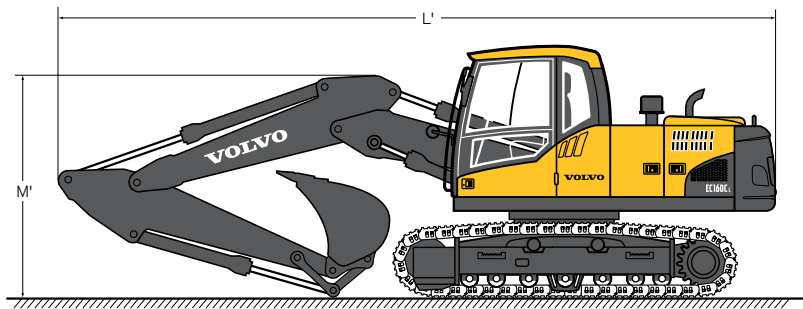
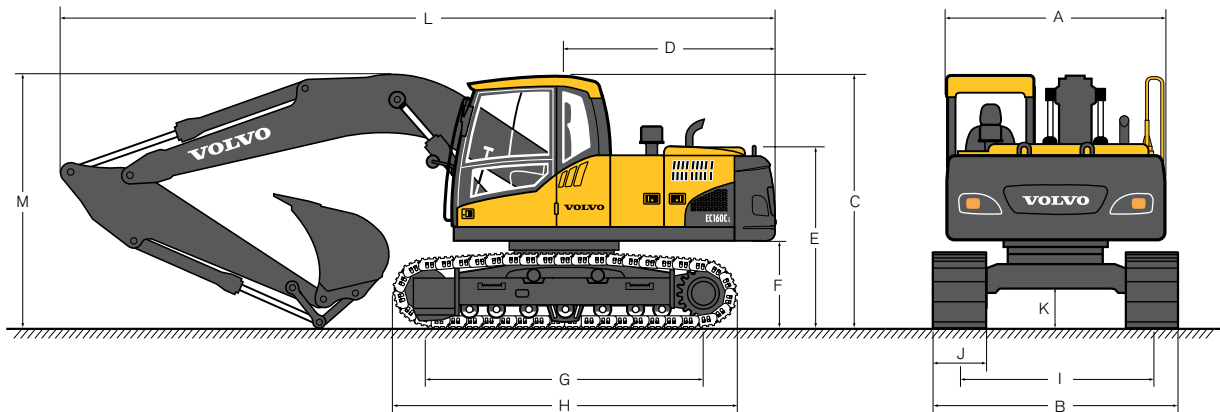

### • EC160C L

Description		5,2 m boom		
		2,3 m arm	2,6 m arm	3,0 m arm
A. Overall width of upper structure	mm	2 490	2 490	2 490
B. Overall width	mm	2 800	2 800	2 800
C. Overall height of cab	mm	2 900	2 900	2 900
D. Tail slew radius	mm	2 450	2 450	2 450
E. Overall height of engine hood	mm	2 110	2 110	2 110
F. Counterweight clearance *	mm	1 010	1 010	1 010
G. Tumbler length	mm	3 180	3 180	3 180
H. Track length	mm	3 980	3 980	3 980
I. Track gauge	mm	2 200	2 200	2 200
J. Shoe width	mm	600	600	600
K. Min. ground clearance *	mm	460	460	460
L. Overall length	mm	8 780	8 670	8 710
L'. Overall length	mm	8 600	8 520	8 520
M. Overall height of boom	mm	2 980	2 900	3 020
M'. Overall height of boom	mm	2 770	2 770	2 930

\* Without shoe grouser



• EC160C NL

Description		5,2 m boom		
		2,3 m arm	2,6 m arm	3,0 m arm
A. Overall width of upper structure	mm	2 490	2 490	2 490
B. Overall width	mm	2 590	2 590	2 590
C. Overall height of cab	mm	2 900	2 900	2 900
D. Tail slew radius	mm	2 450	2 450	2 450
E. Overall height of engine hood	mm	2 110	2 110	2 110
F. Counterweight clearance *	mm	1 010	1 010	1 010
G. Tumbler length	mm	3 180	3 180	3 180
H. Track length	mm	3 980	3 980	3 980
I. Track gauge	mm	1 990	1 990	1 990
J. Shoe width	mm	600	600	600
K. Min. ground clearance *	mm	460	460	460
L. Overall length	mm	8 780	8 670	8 710
L'. Overall length	mm	8 600	8 520	8 520
M. Overall height of boom	mm	2 980	2 900	3 020
M'. Overall height of boom	mm	2 770	2 770	2 930

\* Without shoe grouser

• Boom

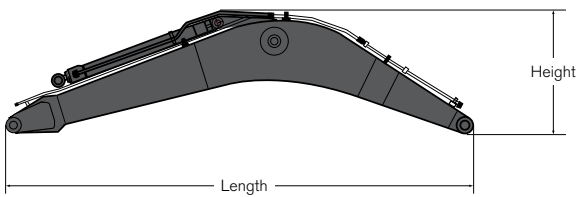

Description		5,2 m	5,0 m 2-piece
Length	mm	5 400	5 200
Height	mm	1 640	1 270
Width	mm	565	565
Weight	kg	1 350	1 600

\* Includes arm cylinder, piping and pin

• Arm

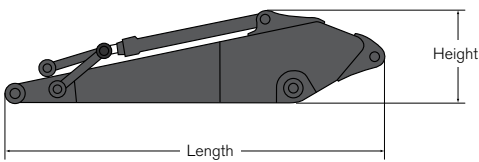

Description		2,3 m	2,6 m	3,0 m
Length	mm	3 240	3 500	3 900
Height	mm	855	855	845
Width	mm	395	395	395
Weight	kg	760	775	840

\* Includes bucket cylinder, linkage and pin

• Front dozer blade

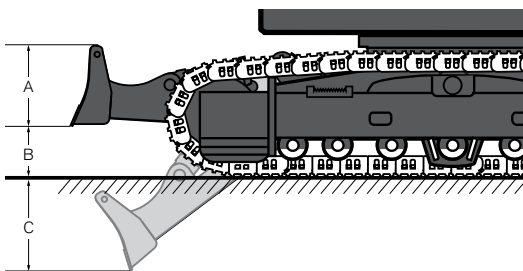

Description		Measurement	
		EC160C L	EC160C NL
A. Height	mm	503	503
Width	mm	2 800	2 590
Weight	kg	595	575
B. Lift height	mm	607	607
C. Digging depth	mm	710	710

## Working ranges & digging force

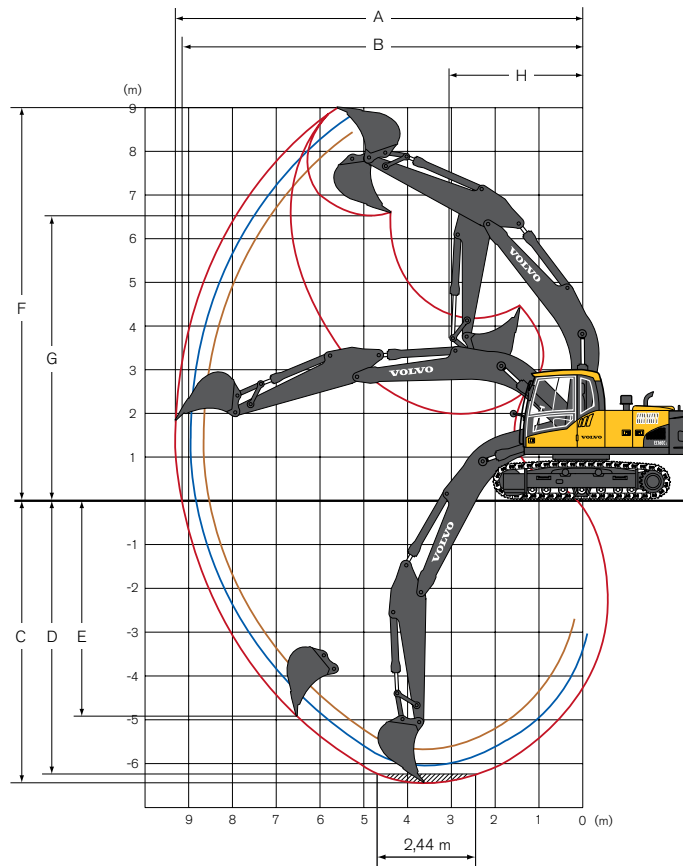

Machine with direct fit bucket		5,2 m boom		
		2,3 m arm	2,6 m arm	3,0 m arm
A. Max. digging reach	mm	8 650	8 970	9 340
B. Max. digging reach on ground	mm	8 490	8 810	9 180
C. Max. digging depth	mm	5 740	6 040	6 440
D. Max. digging depth (2,44 m level)	mm	5 430	5 770	6 200
E. Max. vertical wall digging depth	mm	4 070	4 540	4 960
F. Max. cutting height	mm	8 530	8 790	9 000
G. Max. dumping height	mm	6 110	6 340	6 540
H. Min. front slew radius	mm	3 070	3 070	3 070

Digging forces with direct fit bucket			5,2 m boom		
			2,3 m arm	2,6 m arm	3,0 m arm
Bucket radius	mm	1 315	1 315	1 315	
Breakout force - bucket (Normal/Power boost)	SAE J1179	kN	99,2 / 105,2	99,2 / 105,2	99,2 / 105,2
	ISO 6015	kN	111,3 / 118,1	111,3 / 118,1	111,3 / 118,1
Tearout force - arm (Normal/Power boost)	SAE J1179	kN	84,9 / 90,1	75,5 / 80,0	68,4 / 72,6
	ISO 6015	kN	87,3 / 92,6	77,4 / 82,1	69,9 / 74,1
Rotation angle, bucket	deg.	174	174	174	

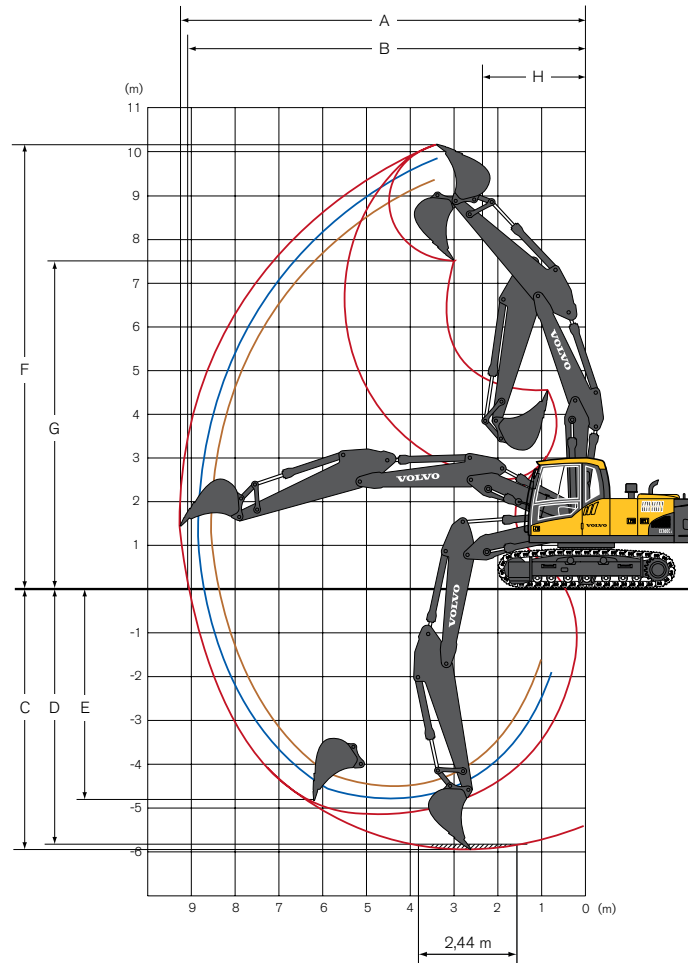

Machine with direct fit bucket		5,0 m 2-piece boom		
		2,3 m arm	2,6 m arm	3,0 m arm
A. Max. digging reach	mm	8 550	8 870	9 240
B. Max. digging reach on ground	mm	8 380	8 700	9 090
C. Max. digging depth	mm	5 210	5 530	5 930
D. Max. digging depth (2,44 m level)	mm	5 090	5 410	5 810
E. Max. vertical wall digging depth	mm	4 070	4 430	4 830
F. Max. cutting height	mm	9 510	9 820	10 120
G. Max. dumping height	mm	6 920	7 210	7 520
H. Min. front slew radius	mm	2 290	2 250	2 350















Digging forces with direct fit bucket			5,0 m 2-piece boom		
			2,3 m arm	2,6 m arm	3,0 m arm
Bucket radius	mm	1 315	1 315	1 315	
Breakout force - bucket (Normal/Power boost)	SAE J1179	kN	99,2 / 105,2	99,2 / 105,2	99,2 / 105,2
	ISO 6015	kN	111,3 / 118,1	111,3 / 118,1	111,3 / 118,1
Tearout force - arm (Normal/Power boost)	SAE J1179	kN	84,9 / 90,1	75,5 / 80,0	68,4 / 72,6
	ISO 6015	kN	87,3 / 92,6	77,4 / 82,1	69,9 / 74,1
Rotation angle, bucket	deg.	174	174	174	

## Lifting capacity

At the arm end without bucket.

For lifting capacity including bucket, simply subtract actual weight of the direct fit bucket or the bucket with quick fit from the following values.

### • EC160C L

 Across undercarriage  Along undercarriage	Lifting hook related to ground level	1,5 m		3,0 m		4,5 m		6,0 m		7,5 m		Max. reach			
														Max. mm	
Boom 5,2 m + Arm 2,3 m + Shoe 600 mm + Counterweight 2 750 kg	7,5 m kg												*4 150	*4 150	4 390
	6,0 m kg												*4 250	3 700	5 931
	4,5 m kg					*4 680	*4 680	*4 390	3 580				4 190	2 930	6 804
	3,0 m kg					*6 190	5 250	4 990	3 450				3 720	2 580	7 260
	1,5 m kg					7 470	4 930	4 830	3 300				3 560	2 460	7 381
	0 m kg			*4 450	*4 450	7 270	4 750	4 720	3 200				3 650	2 510	7 184
	-1,5 m kg			*9 480	8 930	7 230	4 710	4 680	3 170				4 070	2 780	6 640
	-3,0 m kg			*12 250	9 070	7 300	4 780						5 190	3 500	5 644
-4,5 m kg															
Boom 5,2 m + Arm 2,6 m + Shoe 600 mm + Counterweight 2 750 kg	7,5 m kg												*3 880	*3 880	4 838
	6,0 m kg							*3 900	3 690				*3 830	3 430	6 627
	4,5 m kg					*4 300	*4 300	*4 120	3 630				*3 760	2 750	7 096
	3,0 m kg			*9 120	*9 120	*5 800	5 320	*4 760	3 470	3 550	2 460		3 530	2 440	7 535
	1,5 m kg					*7 420	4 950	4 850	3 300	3 480	2 390		3 380	2 320	7 651
	0 m kg			*5 100	*5 100	7 260	4 730	4 710	3 180				3 440	2 350	7 462
	-1,5 m kg	*5 250	*5 250	*9 000	8 780	7 180	4 650	4 650	3 120				3 790	2 570	6 940
	-3,0 m kg	*9 380	*9 380	*12 540	8 900	7 220	4 690						4 700	3 160	5 996
-4,5 m kg			*10 050	9 210								*6 920	5 130	4 351	
Boom 5,2 m + Arm 3,0 m + Shoe 600 mm + Counterweight 2 750 kg	7,5 m kg												*3 550	*3 550	5 413
	6,0 m kg							*3 440	*3 440				*3 240	3 060	6 716
	4,5 m kg							*3 750	3 630				*3 180	2 520	7 495
	3,0 m kg			*7 700	*7 700	*5 260	*5 260	*4 440	3 470	3 550	2 460		3 260	2 250	7 910
	1,5 m kg			*5 150	*5 150	*6 980	4 970	4 830	3 300	3 460	2 380		3 130	2 150	8 021
	0 m kg			*5 570	*5 570	7 240	4 720	4 680	3 160	3 390	2 310		3 180	2 170	7 841
	-1,5 m kg	*4 800	*4 800	*8 440	*8 440	7 130	4 620	4 610	3 090				3 460	2 350	7 347
	-3,0 m kg	*8 160	*8 160	*13 030	8 820	7 150	4 640	4 620	3 110				4 170	2 820	6 465
-4,5 m kg			*11 050	9 080	7 330	4 790						6 250	4 160	4 985	
2-piece boom 5,0 m + Arm 2,3 m + Shoe 600 mm + Counterweight 2 750 kg	7,5 m kg												*5 560	*5 560	4 123
	6,0 m kg					*6 470	5 770						*4 800	3 840	5 740
	4,5 m kg			*7 860	*7 860	*7 010	5 580	5 110	3 540				4 320	2 990	6 638
	3,0 m kg					7 850	5 220	4 970	3 400				3 810	2 620	7 106
	1,5 m kg					7 460	4 880	4 810	3 250				3 650	2 490	7 229
	0 m kg				*4 420	7 240	4 690	4 700	3 150				3 750	2 550	7 028
	-1,5 m kg			*10 160	8 840	7 210	4 660	4 680	3 130				4 220	2 850	6 470
	-3,0 m kg					*5 420	4 760						*4 140	3 730	5 382
2-piece boom 5,0 m + Arm 2,6 m + Shoe 600 mm + Counterweight 2 750 kg	7,5 m kg					*4 790	*4 790						*4 340	*4 340	4 670
	6,0 m kg					*5 540	*5 540	*4 280	3 610				*3 790	3 470	6 139
	4,5 m kg			*5 860	*5 860	*6 350	5 640	5 150	3 570				*3 640	2 770	6 984
	3,0 m kg			*11 850	9 980	*7 770	5 280	5 000	3 430				3 570	2 450	7 430
	1,5 m kg					7 500	4 910	4 820	3 260	3 450	2 360		3 420	2 330	7 548
	0 m kg			*5 630	*5 630	7 250	4 690	4 690	3 150				3 510	2 380	7 355
	-1,5 m kg			*9 670	8 760	7 180	4 630	4 650	3 110				3 890	2 630	6 825
	-3,0 m kg					*6 000	4 710						*3 990	3 290	5 862
2-piece boom 5,0 m + Arm 3,0 m + Shoe 600 mm + Counterweight 2 750 kg	7,5 m kg												*3 590	*3 590	5 270
	6,0 m kg					*4 640	*4 640						*3 190	3 090	6 602
	4,5 m kg					*4 670	*4 670	*4 330	3 660				*3 080	2 520	7 393
	3,0 m kg					*5 130	*5 130	*5 090	3 590				*3 120	2 250	7 814
	1,5 m kg			*10 840	10 270	*7 360	5 340	5 010	3 440	3 510	2 410		3 150	2 140	7 927
	0 m kg			*6 320	*6 320	7 530	4 940	4 810	3 250	3 430	2 330		3 220	2 170	7 744
	-1,5 m kg			*6 050	*6 050	7 230	4 670	4 660	3 110	3 370	2 270		3 530	2 370	7 243
	-3,0 m kg			*9 000	8 630	7 110	4 570	4 590	3 050				*3 970	2 880	6 346
-4,5 m kg					*8 960	8 770	*6 610	4 600	*4 550	3 090					















- Notes:
1. Machine in "Fine Mode-F" (Power Boost) for lifting capacities.
  2. The above loads are in compliance with SAE J1097 and ISO 10567 Hydraulic Excavator Lifting Capacity Standards.
  3. Rated loads do not exceed 87% of hydraulic lifting capacity or 75% of tipping load.
  4. Rated loads marked with an asterisk (\*) are limited by hydraulic capacity rather than tipping load.

## Lifting capacity

At the arm end without bucket.

For lifting capacity including bucket, simply subtract actual weight of the direct fit bucket or the bucket with quick fit from the following values.

### • EC160C NL

 Across undercarriage  Along undercarriage	Lifting hook related to ground level	1,5 m		3,0 m		4,5 m		6,0 m		7,5 m		Max. reach			
														Max. mm	
Boom 5,2 m + Arm 2,3 m + Shoe 600 mm + Counterweight 2 750 kg	7,5 m kg												*4 140	*4 140	4 390
	6,0 m kg							*4 380	3 210				*4 240	3 310	5 931
	4,5 m kg					*4 670	*4 670	4 940	3 080				4 150	2 620	6 804
	3,0 m kg					*6 200	4 670	4 790	2 940				3 680	2 300	7 260
	1,5 m kg					7 420	4 370	4 680	2 850				3 530	2 190	7 381
	0 m kg			*4 420	*4 420	7 230	4 210	4 650	2 810				3 620	2 230	7 184
	-1,5 m kg			*9 450	7 740	7 180	4 170						4 030	2 470	6 640
	-3,0 m kg			*12 280	7 870	7 250	4 230						5 140	3 110	5 644
-4,5 m kg															
Boom 5,2 m + Arm 2,6 m + Shoe 600 mm + Counterweight 2 750 kg	7,5 m kg												*3 880	*3 880	4 838
	6,0 m kg							*3 910	3 310				*3 830	3 070	6 267
	4,5 m kg					*4 300	*4 300	*4 130	3 250				*3 760	2 470	7 096
	3,0 m kg			*9 150	8 620	*5 820	4 730	*4 790	3 110	3 520	2 210		3 500	2 190	7 535
	1,5 m kg					7 450	4 400	4 810	2 960	3 460	2 150		3 360	2 080	7 651
	0 m kg			*5 100	*5 100	7 220	4 200	4 680	2 840				3 430	2 110	7 462
	-1,5 m kg	*5 250	*5 250	*9 000	7 640	7 150	4 140	4 630	2 800				3 780	2 310	6 940
	-3,0 m kg	*9 380	*9 380	*12 670	7 770	7 200	4 180						4 680	2 840	5 996
-4,5 m kg			*10 170	8 050								*7 010	4 590	4 351	
Boom 5,2 m + Arm 3,0 m + Shoe 600 mm + Counterweight 2 750 kg	7,5 m kg												*3 610	*3 610	5 403
	6,0 m kg							*3 520	3 400				*3 310	2 820	6 708
	4,5 m kg							*3 820	3 330				*3 250	2 320	7 488
	3,0 m kg			*7 790	*7 790	*5 350	4 840	*4 520	3 180	3 580	2 260		3 300	2 080	7 904
	1,5 m kg			*5 260	*5 260	*7 060	4 470	4 860	3 010	3 500	2 180		3 170	1 980	8 015
	0 m kg			*5 680	*5 680	7 260	4 230	4 710	2 870	3 430	2 120		3 230	2 000	7 834
	-1,5 m kg	*4 910	*4 910	*8 540	7 570	7 140	4 140	4 640	2 810				3 510	2 160	7 340
	-3,0 m kg	*8 260	*8 260	*13 120	7 670	7 170	4 150	4 660	2 820				4 210	2 570	6 457
-4,5 m kg			*11 140	7 920	7 340	4 300						6 290	3 760	4 974	
2-piece boom 5,0 m + Arm 2,3 m + Shoe 600 mm + Counterweight 2 750 kg	7,5 m kg												*5 060	*5 060	4 195
	6,0 m kg					*6 290	5 160						*4 330	3 380	5 791
	4,5 m kg			*7 540	*7 540	*7 000	4 970	5 070	3 160				*4 150	2 640	6 682
	3,0 m kg					7 790	4 640	4 930	3 040				3 740	2 310	7 147
	1,5 m kg					7 420	4 320	4 770	2 900				3 590	2 190	7 270
	0 m kg			*5 080	*5 080	7 210	4 150	4 670	2 800				3 690	2 240	7 069
	-1,5 m kg			*10 220	7 660	7 180	4 120	4 650	2 780				4 150	2 510	6 515
	-3,0 m kg					*5 440	4 210						*4 150	3 310	5 381
2-piece boom 5,0 m + Arm 2,6 m + Shoe 600 mm + Counterweight 2 750 kg	7,5 m kg					*4 790	*4 790						*4 340	*4 340	4 670
	6,0 m kg					*5 550	*5 240	*4 290	3 250				*3 790	3 120	6 139
	4,5 m kg			*5 870	*5 870	*6 360	5 050	5 120	3 210				*3 650	2 480	6 984
	3,0 m kg			*11 870	8 700	*7 780	4 710	4 970	3 070				3 550	2 190	7 430
	1,5 m kg					7 460	4 360	4 790	2 910	3 440	2 100		3 400	2 080	7 548
	0 m kg			*5 630	*5 630	7 210	4 140	4 670	2 800				3 490	2 120	7 355
	-1,5 m kg			*9 670	7 560	7 140	4 090	4 620	2 760				3 870	2 340	6 825
	-3,0 m kg					*6 020	4 160						*4 010	2 930	5 862
2-piece boom 5,0 m + Arm 3,0 m + Shoe 600 mm + Counterweight 2 750 kg	7,5 m kg					*4 670	*4 670						*3 620	*3 620	5 262
	6,0 m kg					*4 710	*4 710	*4 360	3 310				*3 220	2 790	6 595
	4,5 m kg					*5 180	5 140	*5 130	3 240				*3 110	2 270	7 387
	3,0 m kg			*10 850	8 970	*7 380	4 780	5 000	3 090	3 510	2 160		*3 150	2 020	7 809
	1,5 m kg			*6 410	*6 410	7 490	4 380	4 800	2 910	3 430	2 090		3 150	1 920	7 921
	0 m kg			*6 120	*6 120	7 180	4 110	4 640	2 770	3 360	2 030		3 220	1 940	7 738
	-1,5 m kg			*9 080	7 400	7 070	4 010	4 570	2 710				3 520	2 120	7 237
	-3,0 m kg					*8 960	7 540	6 620	4 050	*4 570	2 750		*4 000	2 570	6 340

- Notes:
1. Machine in "Fine Mode-F" (Power Boost) for lifting capacities.
  2. The above loads are in compliance with SAE J1097 and ISO 10567 Hydraulic Excavator Lifting Capacity Standards.
  3. Rated loads do not exceed 87% of hydraulic lifting capacity or 75% of tipping load.
  4. Rated loads marked with an asterisk (\*) are limited by hydraulic capacity rather than tipping load.

## STANDARD EQUIPMENT

### Engine

Turbocharged, 4 stroke diesel engine with water cooling, direct injection and charged air cooler that meets EU Stage IIIA requirements  
3-stage air filter with indicator and precleaner  
Air intake heater  
Electric engine shut-off  
Fuel filter and water separator  
Fuel filler pump: 50 l/min, with automatic shut-off  
Alternator, 80 A

### Electric/Electronic control system

Contronics  
- Advanced mode control system  
- Self-diagnostic system  
Machine status indication  
Engine speed sensing power control  
Automatic idling system  
One-touch power boost  
Safety stop/start function  
Adjustable LCD color monitor  
Master electrical disconnect switch  
Engine restart prevention circuit  
High-capacity halogen lights:  
- Frame-mounted 2  
- Boom-mounted 2  
Batteries, 2 x 12 V / 140 Ah  
Start motor, 24 V / 4,8 kW

### Hydraulic system

Hose rupture valve: boom  
Overload warning device

Automatic sensing hydraulic system  
- Summation system  
- Boom priority  
- Arm priority  
- Slew priority  
Boom, arm and bucket regeneration valves  
Slew anti-rebound valves  
Boom and arm holding valves  
Multi-stage filtering system  
Cylinder cushioning  
Cylinder contamination seals  
Auxiliary hydraulic valve  
Automatic two-speed travel motors  
Hydraulic oil, ISO VG 46

### Superstructure

Access way with handrail  
Full height counterweight: 2 750 kg  
Tool storage area  
Punched metal anti-slip plates  
Undercover (heavy-duty 4,5 mm)

### Cab and interior

Fabric seat with heater and air suspension  
Control joysticks with 4 switches each  
Heater & air-conditioner, automatic  
Hydraulic dampening cab mounts  
Adjustable operator seat and joystick control console  
Flexible antenna  
Hydraulic safety lock lever  
Cab, all-weather sound suppressed, includes:  
- Ashtray  
- Cup holder (X3)

- Lighter  
- Door locks  
- Tinted glass  
- Floor mat  
- Horn  
- Large storage area  
- Pull-up type front window  
- Removable lower windshield  
- Seat belt  
- Safety glass  
- Sun shields, front, roof, rear  
- Rain shield  
- Windshield wiper with intermittent feature  
Anti-vandalism kit assembly preparation  
Master ignition key  
Opening top hatch

### Undercarriage

Hydraulic track adjusters  
Greased and sealed track chain  
Track guide  
Undercover (heavy-duty 10 mm)

### Track shoes

Track shoes 600 mm with triple grousers

### Digging equipment

Boom: 5,2 m monoblock  
Arm: 2,6 m  
Centralized lubrication

### Service

Tool kit, daily maintenance

## OPTIONAL EQUIPMENT

### Engine

Block heater: 120 V, 240 V  
Oil bath pre-cleaner  
Diesel driven coolant heater  
Water separator with heater

### Electric

Extra lamps:  
- Cab-mounted 1  
- Counterweight-mounted 1  
Travel alarm  
Anti-theft system  
Rotating warning beacon

### Hydraulic system

Hose rupture valve: arm  
Boom float function  
Hydraulic piping:  
- Hammer & shear, 1 and 2 pump flow

- Slope & rotator  
- Grapple  
- Oil leak (drain) line  
- Quick fit piping  
Volvo hydraulic quick fit, S1, S6 size  
Hydraulic oil, ISO VG 32  
Hydraulic oil, ISO VG 68  
Hydraulic oil, biodegradable 32  
Hydraulic oil, biodegradable 46

### Cab and interior

Fabric seat  
Fabric seat with heater  
Control joystick with semi-long levers  
Control joystick with proportional control  
Falling object guard (FOG)  
- Cab-mounted  
Cab-mounted falling object protective structure (FOPS)

Screen guard for front window  
Sunlight protection, roof (steel)  
Lower wiper with intermittent control  
Anti-vandalism kit  
Specific key  
Rear view camera

### Undercarriage

Full track guard

### Digging equipment

Boom: 5,0 m 2-piece  
Arm: 2,3 / 3,0 m

### Service

Tool kit, full scale

**NOTE**



Volvo Construction Equipment is different. It's designed, built and supported in a different way. That difference comes from an engineering heritage of over 170 years. A heritage of thinking first about the people who actually use the machines. About how to help them be safer, more comfortable, more productive. About the environment we all share. The result of that thinking is a growing range of machines and a global support network dedicated to helping you do more. People around the world are proud to use Volvo. And we're proud of what makes Volvo different – **More care. Built in.**



*Not all products are available in all markets. Under our policy of continuous improvement, we reserve the right to change specifications and design without prior notice. The illustrations do not necessarily show the standard version of the machine.*

**VOLVO**

**Construction Equipment**  
**[www.volvo.com](http://www.volvo.com)**

Ref. No. 21 D 100 2693 English (Global)  
Printed in Sweden 2007.07-1,0 EXC  
Volvo, Seoul