

VOLVO EXCAVATOR

EC390

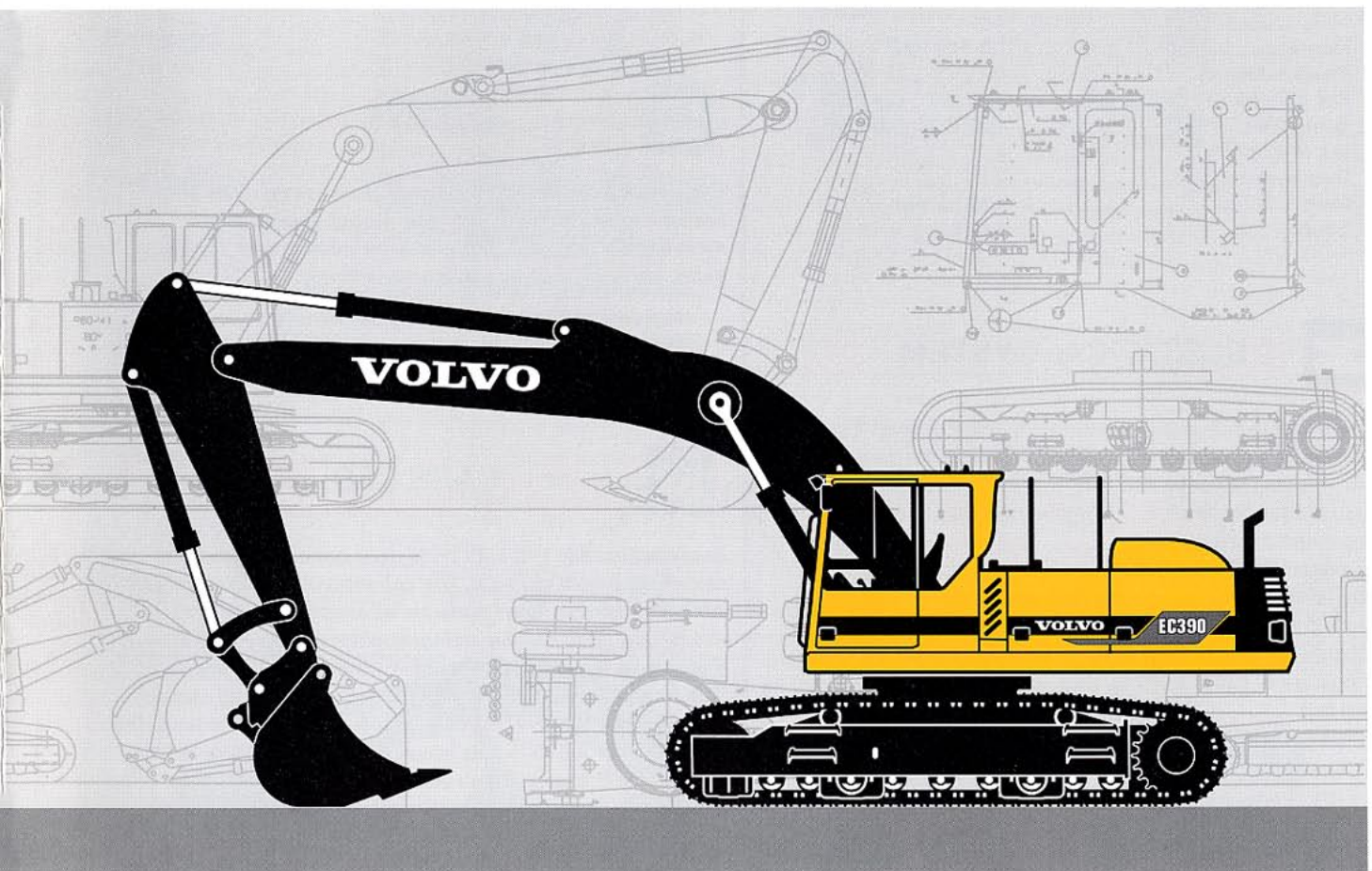

- **Engine power, gross:**
190 kW (258 hp)
- **Operating weight:**
39,0 – 40,9 t
- **Buckets:**
1 500 – 3 400 l
- Low-emission, turbocharged Volvo diesel engine with direct injection and intercooler
- Mode selector and electronically controlled Speed Sensing Control (SSC)
- 3 pumps in 3 circuits
Each movement of the digging equipment is prioritized by its own circuit, ensuring independent movements and good precision
- Care Cab
 - computerized monitoring system, Contronic E
 - ergonomic environment
 - low sound level
 - filtered air
- Rugged digging equipment with spherical steel bearings
- High lifting, breakout and tearout forces for tough digging conditions
- Long undercarriage for good stability
- Slew circuit in oil bath
- Prepared for a number of optional items of equipment
- Low transport dimensions
- High travel speed – 4,5 km/h

VOLVO



ENGINE

The engine is a low-emission, turbocharged, 4-stroke diesel engine with intercooler, specially developed for excavator use. The machine can work at low engine speeds, contributing to good fuel economy, low sound level, less wear and longer life. Daily checkup of oil and coolant levels etc. is done directly from the cab.

Air filter: 3-stage

Auto Decelerator: Reduces the engine speed to an idling speed when levers and pedals are not activated.

Make	Volvo
Model	TD 103 KAE
Power output at	28,3 r/s (1 700 r/min)
Net (ISO 9249 / DIN 6271)	182 kW (247 hp)
Gross (SAE J1349)	190 kW (258 hp)
No. of cylinders	6
Displacement, total	9,6 l
Bore	120,65 mm
Stroke	140 mm



ELECTRICAL SYSTEM

Well-protected electrical system with high capacity. Electrical distribution box based on printed circuit boards contains clearly arranged fuses and relays. The distribution box is prepared for connection of optional equipment. Battery disconnecter is standard.

Advanced **Contronic E monitoring system**, offering exhaustive information on machine status and enabling the operator to seek specific information and make his own adjustments, is standard. Alarms are indicated on the display in the form of flashing lights, with supplementary information in plain text.

Voltage	24 V
Batteries	2 x 12 V
Battery capacity	170 Ah
Alternator	28 V / 55 A
Alternator rating	1 540 W



SLEW SYSTEM

The superstructure is slewed by means of an axial piston motor and a planetary gearbox. Slew priority with 3 power positions. Automatic slew holding brake. The slew ring works in an oil bath.

Slew, start to stop*	
90° slew	5,5 s
180° slew	7,2 s
Slew speed	8,6 r/min

* Empty bucket – extended equipment.



SERVICE REFILL CAPACITIES

Fuel tank	720 l
Hydraulic system, total	470 l
Diesel engine oil	37,5 l
Cooling system incl. glycol	58 l
Slew ring	24 l



UNDERCARRIAGE

Undercarriage with robust frame construction. Permanently lubricated rollers and front idlers. Three derailing shields are standard.

The undercarriage is operated by means of rocker pedals.

Track chain size	D85
No. of track shoes	2 x 51
Track gauge	600 mm
alt.	700/800/900 mm
No. of bottom rollers	2 x 9
No. of top rollers	2 x 2
alt. skid rails	2 x 1



DRIVE

Each track is powered by an axial piston motor. The track brakes are of the multi-disc type, spring-applied and hydraulically released. Travel motors, brakes and planetary gears are well protected in the track frame.

Max. tractive force, gross	374 kN
Max. tractive force, net	275 kN
Max. travel speed	4,5 km/h
Gradeability	49°



CARE CAB

Easily accessible cab with wide door opening. Lined with sound-absorbent material. The cab mountings are vibration-inhibiting. Large glazed surfaces all around. The upper windshield pane can be slid up into the ceiling and the lower one can be removed. Sliding side window in the cab door.

Cab heater and defroster: Pressurized and filtered cab air is supplied by a 3-speed fan underneath the operator's seat. The air passes through the cab heater and can be distributed via 14 nozzles. Prepared for air conditioning.

Ergonomic operator's seat: Electrically heated operator's seat with adjustable suspension and headrest. The fore/aft position, height and angle of the seat are adjustable, as is the lumbar support. Individually adjustable armrests and control levers.

Sound level: Approved according to Directive 86/662/EEC.

Exterior noise (ISO 6 395)	
mean value of L_{wA} (sound power level)	107 dB(A)
Operator's position (ISO 6 396)	
with the door closed	
mean value of L_{pA} (sound pressure level)	72 dB(A)



GROUND PRESSURE

Machine with 7,0 m boom, 2,9 m dipper arm, 2 000 kg bucket and 7 300 kg counterweight.

Track gauge	Operating weight	Ground pressure
600 mm	39 200 kg	69,4 kPa
700 mm	39 700 kg	60,2 kPa
800 mm	40 200 kg	53,3 kPa
900 mm	40 700 kg	48,0 kPa



HYDRAULIC SYSTEM

The three-circuit hydraulic system, named "Excellence", is designed for high digging capacity, high manoeuvring precision and good fuel economy.

The three working pumps are power-controlled, and each can be directed to its own particular equipment movement for precision work. One pump is prioritized to the slew movement.

The following important functions are included in the system:

- Power Booster (HLD)** – All digging, lifting and tractive forces are increased
- Slew priority** – Power distribution between boom lift and slew movement to obtain best performance
- Decelerator** – Permits digging speed to be varied during a digging cycle (saves fuel)
- Float position** – For more efficient topsoil stripping and grab work and better operator comfort and fuel economy

Automatic Decelerator and Speed Sensing Control are also included for optimum utilization of the engine. Hose rupture valves on the boom cylinders are standard.

Pump P1 (slew, bucket, optional equipment)

Max. pressure 31 MPa
Max. flow 203 l/min

Pumps P2 and P3 (boom, dipper arm, bucket, travel motors, optional equipment)

Max. pressure 31 MPa
Max. pressure with HLD 35 MPa
Max. flow 2 x 253 l/min

Servo pump

Pressure 6,5 MPa
Flow 21 l/min

Fan pump

Pressure 21 MPa
Flow 29 l/min

DIMENSIONS

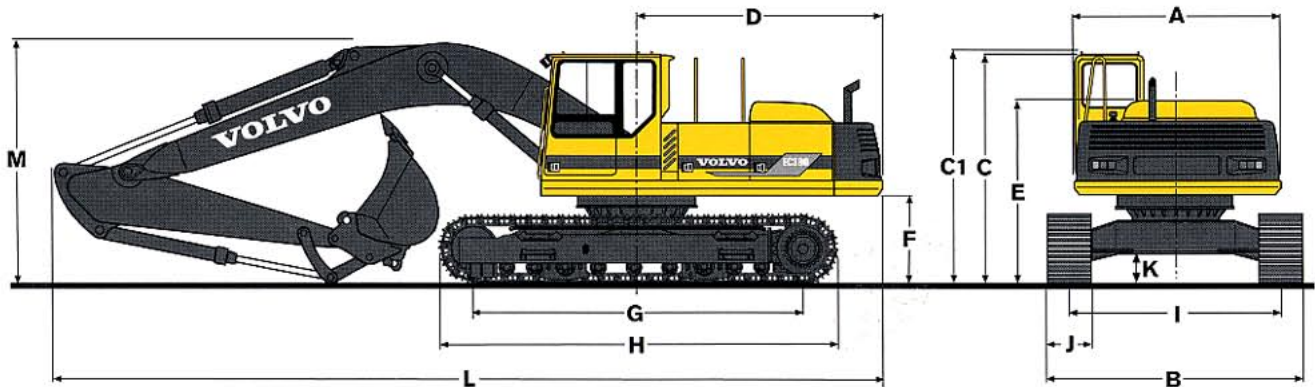

A: mm 2 950	L: mm 10 600	Boom	Dipper arm
B: mm 3 500/ 3 600/ 3 700/3 800	L: mm 10 500	6,0 m	2,2 m – ME digging equipment
C: mm 3 190	L: mm 11 600	6,0 m	2,4 m, 2,9 m and 3,5 m
C1: mm 3 240	L: mm 11 500	7,0 m	2,4 m
D: mm 3 300	L: mm 11 400	7,0 m	2,9 m and 3,5 m
E: mm 2 540		7,0 m	4,1 m
F: mm 1 260	M: mm 3 340	6,0 m	2,2 m – ME digging equipment
G: mm 4 260	M: mm 3 250/ 3 240*	6,0 m	2,4 m
H: mm 5 260	M: mm 3 390/ 3 240*	6,0 m	2,9 m
I: mm 2 900	M: mm 3 570/ 3 240*	6,0 m	3,5 m
J: mm 600/ 700/ 800/ 900	M: mm 3 350/ 3 240*	7,0 m	2,4 m
K: mm 490	M: mm 3 490/ 3 490*	7,0 m	2,9 m
	M: mm 3 510/ 3 330*	7,0 m	3,5 m
	M: mm 3 300/ 3 330*	7,0 m	4,1 m

* Without bucket

DIGGING RANGES

Monobloc boom 6,0 m and dipper arm 2,2 m – ME digging equipment

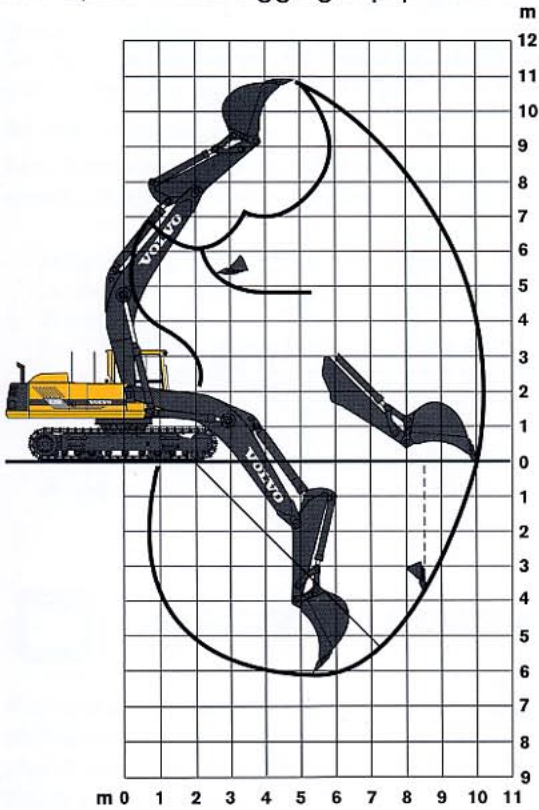

Monobloc boom 6,0 m and dipper arm 2,4 / 2,9 / 3,5 m

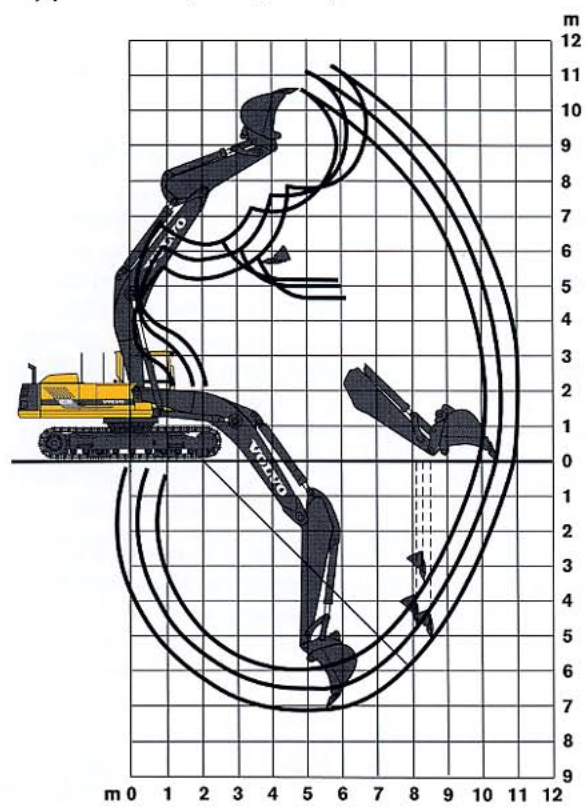

Monobloc boom	m	6,0	6,0	6,0	6,0
Dipper arm	m	2,2 ME	2,4	2,9	3,5
Max. reach	m	10,2	10,0	10,6	11,1
Max. reach at ground level	m	10,0	9,8	10,4	10,9
Max. digging depth	m	5,8	6,0	6,5	7,1
Max. height ground – tooth tip	m	10,8	10,7	11,2	11,4
Max. dumping height	m	7,0	7,1	7,6	7,8
Max. practical dumping height	m	4,8	5,1	4,9	4,6
Practical digging depth for a material					
with a 45° angle of repose	m	5,2	5,0	5,4	5,8
Max. vertical digging depth	m	3,7	3,6	4,7	5,0
Min. front slew radius	m	3,1	3,2	3,1	3,1

Digging forces with pin-on GP bucket:					
Bucket radius	m	1,92	1,64	1,64	1,64
Breakout force	kN	244	255	255	255
Tearout force	kN	204	204	181	159
Rotation angle, bucket	°	155	175	175	175

Max. permitted buckets for pin-on:					
GP bucket 1,5 t/m ³	l	3 400	3 400	3 100	2 800
GP bucket 1,8 t/m ³	l	3 000	3 000	2 700	2 450
RB bucket 1,8 t/m ³	l	2 850	2 850	2 600	2 350
RB bucket 2,0 t/m ³	l	2 650	2 650	2 400	2 150

Max. permitted buckets for quickfit:					
GP bucket 1,5 t/m ³	l	–	3 300	2 950	2 700
GP bucket 1,8 t/m ³	l	–	2 900	2 600	2 350
RB bucket 1,8 t/m ³	l	–	2 750	2 500	2 250
RB bucket 2,0 t/m ³	l	–	2 550	2 300	2 100

DIGGING RANGES

Monobloc boom 7,0 m and
dipper arm 2,4 / 2,9 / 3,5 / 4,1 m

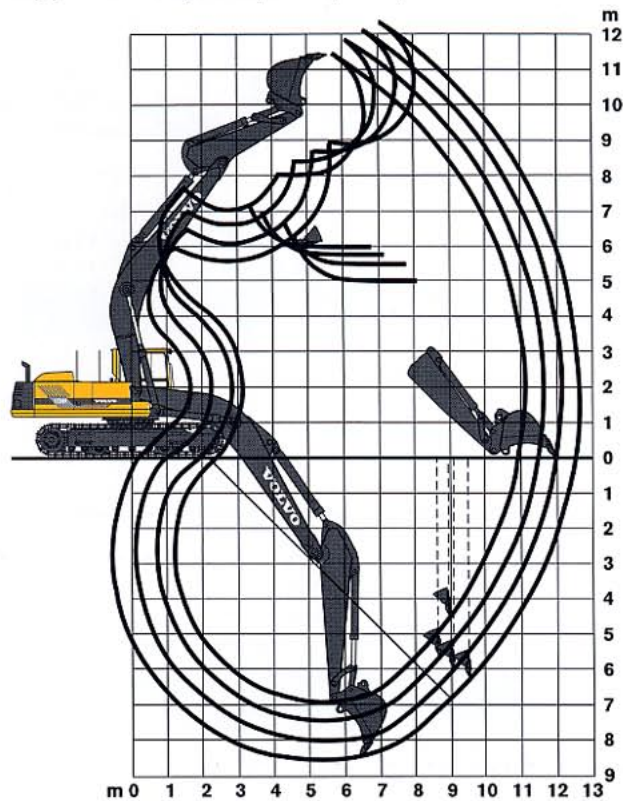

Monobloc boom	m	7,0	7,0	7,0	7,0
Dipper arm	m	2,4	2,9	3,5	4,1
Max. reach	m	11,1	11,6	12,1	12,6
Max. reach at ground level	m	10,9	11,4	12,0	12,4
Max. digging depth	m	6,9	7,4	8,0	8,6
Max. height ground – tooth tip	m	11,5	12,0	12,2	12,3
Max. dumping height	m	7,9	8,4	8,6	8,6
Max. practical dumping height	m	5,9	5,7	5,5	5,2
Practical digging depth for a material with a 45° angle of repose	m	5,8	6,1	6,5	6,8
Max. vertical digging depth	m	4,4	5,5	5,8	6,1
Min. front slew radius	m	3,9	3,7	3,7	3,7

Digging forces with pin-on GP bucket:

Bucket radius	m	1,64	1,64	1,64	1,64
Breakout force	kN	255	255	255	255
Tearout force	kN	204	181	159	142
Rotation angle, bucket	°	175	175	175	175















Max. permitted buckets for pin-on:

GP bucket 1,5 t/m ³	l	2 700	2 450	2 250	2 050
GP bucket 1,8 t/m ³	l	2 400	2 150	1 950	1 800
RB bucket 1,8 t/m ³	l	2 300	2 050	1 850	1 750
RB bucket 2,0 t/m ³	l	2 100	1 900	1 750	1 600

Max. permitted buckets for quickfit:

GP bucket 1,5 t/m ³	l	2 600	2 350	2 100	1 950
GP bucket 1,8 t/m ³	l	2 300	2 050	1 850	1 700
RB bucket 1,8 t/m ³	l	2 200	2 000	1 800	1 650
RB bucket 2,0 t/m ³	l	2 050	1 850	1 650	1 500

LIFTING CAPACITY (In dipper pin without bucket. Unit: 1 000 kg.)

 Across under-carriage  Along under-carriage	Lifting point related to ground level	Reach from machine centre														
		3,0 m		4,5 m		6,0 m		7,5 m		9,0 m		Max. reach				
														Max. m		
ME digging equipment 6,0 m mono-bloc boom 2,2 m dipper arm Track gauge 600 mm	7,5 m			13,1*	13,1*									9,9*	9,9*	5,8
	6,0 m			13,7*	13,7*	12,0*	12,0*							8,7*	8,7*	7,0
	4,5 m			15,8*	15,8*	11,6	12,6*							8,1	8,3*	7,7
	3,0 m			16,4	18,3*	11,0	13,6*	8,4	11,0*					7,4	9,3*	8,0
	1,5 m			15,9	19,3*	10,5	14,2*	7,9	11,4*					7,1	9,1*	8,1
	0,0 m			15,7	18,4*	10,3	14,0*	7,7	11,0*					7,4	10,4*	7,8
	-1,5 m	18,1*	18,1*	15,7	16,3*	10,3	12,8*							8,1	9,9*	7,3
	-3,0 m			12,9*	12,9*	9,9*	9,9*							9,1*	9,1*	6,3
6,0 m mono-bloc boom 2,4 m dipper arm Track gauge 600 mm	7,5 m			12,6*	12,6*									8,4*	8,4*	5,9
	6,0 m			13,2*	13,2*	11,6*	11,6*							7,3*	7,3*	7,1
	4,5 m	23,3*	23,3*	15,3*	15,3*	11,6	12,3*	8,4	10,2*					8,0	8,2*	7,7
	3,0 m			16,5	17,9*	11,0	13,4*	8,1	11,1*					7,3	7,9*	8,1
	1,5 m			15,8	19,2*	10,5	14,1*	7,8	11,3*					7,1	9,5*	8,1
	0,0 m			15,6	18,6*	10,3	14,0*	7,7	11,0*					7,2	10,3*	7,9
	-1,5 m	20,0*	20,0*	15,6	16,7*	10,2	12,9*							7,8	10,0*	7,4
	-3,0 m	15,9*	15,9*	13,4*	13,4*	10,4*	10,4*							9,4*	9,4*	6,4
6,0 m mono-bloc boom 2,9 m dipper arm Track gauge 600 mm	7,5 m					9,2*	9,2*							6,8*	6,8*	6,6
	6,0 m			11,6*	11,6*	10,8*	10,8*	7,3*	7,3*					5,9*	5,9*	7,7
	4,5 m	20,4*	20,4*	14,3*	14,3*	11,7*	11,7*	8,4	10,3*					6,1*	6,1*	8,3
	3,0 m			17,0	17,2*	11,1	12,9*	8,1	10,8*					6,6*	6,6*	8,6
	1,5 m			16,1	19,1*	10,6	13,9*	7,8	11,1*					6,3	6,5*	8,7
	0,0 m	8,7*	8,7*	15,7	19,1*	10,3	14,1*	7,6	11,1*					6,5	7,0*	8,5
	-1,5 m	17,3*	17,3*	15,7	17,7*	10,2	13,4*	7,6	10,3*					7,0	8,2*	8,0
	-3,0 m	18,9*	18,9*	14,9*	14,9*	10,3	11,4*							8,3	8,9*	7,1
-4,5 m			10,1*	10,1*									7,6*	7,6*	5,7	
6,0 m mono-bloc boom 3,5 m dipper arm Track gauge 600 mm	7,5 m					8,0*	8,0*							4,8*	4,8*	7,3
	6,0 m					9,1*	9,1*	7,4*	7,4*					4,8*	4,8*	8,2
	4,5 m			12,5*	12,5*	10,8*	10,8*	8,4	9,4*					4,8*	4,8*	8,8
	3,0 m	22,1*	22,1*	15,9*	15,9*	11,2	12,2*	8,1	10,2*	5,7*	5,7*			5,0*	5,0*	9,1
	1,5 m	8,2*	8,2*	16,3	18,3*	10,7	13,4*	7,7	10,8*	5,9	6,6*			5,0*	5,0*	9,2
	0,0 m	11,2*	11,2*	15,7	19,1*	10,3	14,0*	7,5	11,0*	5,5*	5,5*			5,5*	5,5*	9,0
	-1,5 m	16,8*	16,8*	15,5	18,3*	10,1	13,6*	7,4	10,6*					6,3	6,8*	8,5
	-3,0 m	21,7*	21,7*	15,5	16,1*	10,1	12,2*	7,4	9,1*					7,2	8,7*	7,7
-4,5 m	15,7*	15,7*	12,2*	12,2*	9,0*	9,0*							7,8*	7,8*	6,5	

Note: For lift capacity including quickfit or bucket, simply subtract actual weight of quickfit or bucket from the above values. (Quickfit S3, weight 300 kg.)















* Load capacity limited by machine's hydraulic lifting capacity.

The above values have been calculated in compliance with ISO standard 10 567.

They do not exceed 87 % of hydraulic lifting capacity or 75 % of tipping load, with the machine on firm, level ground.

Working pressure with HLD = 35 MPa (350 bar/ 5 080 psi)

LIFTING CAPACITY (In dipper pin without bucket. Unit: 1 000 kg.)

 Across under-carriage  Along under-carriage	Lifting point related to ground level	Reach from machine centre														
		3,0 m		4,5 m		6,0 m		7,5 m		9,0 m		Max. reach		Max. m		
																
7,0 m mono-bloc boom 2,4 m dipper arm Track gauge 600 mm	7,5 m					10,0*	10,0*							8,1*	8,1*	7,3
	6,0 m	18,0*	18,0*	12,8*	12,8*	10,5*	10,5*	8,4	9,4*					7,3	8,3*	8,2
	4,5 m			15,7*	15,7*	11,0	11,6*	8,0	9,8*					6,3	8,3*	8,8
	3,0 m					10,3	12,8*	7,6	10,3*	5,9	8,7			5,8	8,6	9,1
	1,5 m					9,8	13,5*	7,3	10,6*	5,8	8,5			5,6	8,3	9,2
	0,0 m					9,6	13,4*	7,1	10,6*	5,7	8,4			5,7	8,4	9,0
	-1,5 m			15,0	15,5*	9,5	12,6*	7,1	10,1*					6,1	8,6*	8,5
	-3,0 m			13,3*	13,3*	9,6	11,0*	7,2	8,6*					7,0	8,3*	7,7
-4,5 m			10,0*	10,0*	8,2*	8,2*							7,3*	7,3*	6,5	
7,0 m mono-bloc boom 2,9 m dipper arm Track gauge 600 mm	9,0 m					9,3*	9,3*							6,6*	6,6*	6,7
	7,5 m					9,2*	9,2*	8,6	8,7*					6,1*	6,1*	8,0
	6,0 m			11,8*	11,8*	9,9*	9,9*	8,4	8,8*					6,5	6,5*	8,8
	4,5 m			14,6*	14,6*	11,1*	11,1*	8,1	9,3*	6,1	8,3*			5,7	6,1*	9,4
	3,0 m					10,5	12,4*	7,7	10,0*	5,9	8,6*			5,2	6,1*	9,7
	1,5 m					10,0	13,3*	7,3	10,5*	5,7	8,5			5,1	7,0*	9,7
	0,0 m			12,2*	12,2*	9,7	13,5*	7,1	10,6*	5,6	8,3			5,2	7,7	9,5
	-1,5 m			14,9	16,5*	9,5	12,9*	7,0	10,3*	5,5	8,1*			5,5	8,0*	9,1
-3,0 m	17,1*	17,1*	14,5*	14,5*	9,6	11,6*	7,1	9,2*					6,1	7,7*	8,4	
-4,5 m			11,6*	11,5*	9,3*	9,3*							7,2*	7,2*	7,2	
7,0 m mono-bloc boom 3,5 m dipper arm Track gauge 600 mm	7,5 m							7,8*	7,8*					4,7*	4,7*	8,6
	6,0 m							8,1*	8,1*	6,2	6,5*			4,6*	4,6*	9,4
	4,5 m			13,1*	13,1*	10,3*	10,3*	8,1	8,7*	6,0	7,8*			4,8*	4,8*	9,9
	3,0 m			16,1	16,2*	10,6	11,7*	7,7	9,5*	5,8	8,1*			4,7*	4,7*	10,2
	1,5 m			14,8*	14,8*	10,0	12,8*	7,3	10,1*	5,6	8,4			4,6	5,4*	10,2
	0,0 m			14,6	15,1*	9,6	13,3*	7,0	10,4*	5,4	8,2			4,7	6,1*	10,0
	-1,5 m	9,8*	9,8*	14,5	17,2*	9,4	13,0*	6,9	10,3*	5,3	8,1			4,9	6,8*	9,6
	-3,0 m	16,1*	16,1*	14,6	15,5*	9,4	12,1*	6,8	9,5*					5,5	7,5*	8,9
-4,5 m	16,1*	16,1*	12,9*	12,9*	9,5	10,2*	7,0	7,8*					6,6	7,1*	7,9	
-6,0 m			8,8*	8,8*	6,7*	6,7*							6,2*	6,2*	6,3	
7,0 m mono-bloc boom 4,1 m dipper arm Track gauge 600 mm	9,0 m					5,4*	5,4*							4,1*	4,1*	8,0
	7,5 m					6,8*	6,8*	4,3*	4,3*					3,9*	3,9*	9,1
	6,0 m			8,2*	8,2*	7,5*	7,5*	6,3	6,3*					3,7*	3,7*	9,9
	4,5 m	11,8*	11,8*	9,5*	9,5*	8,2*	8,2*	6,1	7,3*					3,8*	3,8*	10,4
	3,0 m	14,9*	14,9*	10,8	11,0*	7,8	9,0*	5,8	7,8*	4,5	4,8*			4,2*	4,2*	10,6
	1,5 m	15,3	17,2*	10,1	12,3*	7,3	9,7*	5,6	8,1*	4,4	5,4*			4,2*	4,2*	10,7
	0,0 m	14,6	17,8*	9,6	13,0*	7,0	10,2*	5,4	8,1*	4,3	4,8*			4,3	4,8*	10,5
	-1,5 m	14,3	17,5*	9,3	13,1*	6,8	10,2*	5,2	8,0*					4,5	5,5*	10,1
-3,0 m	14,3	16,2*	9,2	12,4*	6,7	9,8*	5,2	7,7*					4,9	6,1*	9,5	
-4,5 m	14,1*	14,1*	9,3	10,9*	6,8	8,5*							5,8	7,0*	8,5	
-6,0 m	10,6*	10,6*	8,3*	8,3*									6,5*	6,5*	7,1	

Note: For lift capacity including quickfit or bucket, simply subtract actual weight of quickfit or bucket from the above values. (Quickfit S3, weight 300 kg.)

* Load capacity limited by machine's hydraulic lifting capacity.

The above values have been calculated in compliance with ISO standard 10 567.

They do not exceed 87 % of hydraulic lifting capacity or 75 % of tipping load, with the machine on firm, level ground.

Working pressure with HLD = 35 MPa (350 bar/ 5 080 psi)

STANDARD EQUIPMENT

Engine and electrical system

Contronic E – computerized monitoring and alarm system
 Battery disconnecter and main fuel cock
 Decelerator – electronic idling speed
 Auto idling
 Electronically controlled pump regulation (SSC)
 3-stage air filter with indicator
 Hour meter
 Tachometer
 Fuel level gauge
 Temperature gauge for coolant and hydraulic oil
 Electric preheating coil
 24 V electrical system
 Well-protected electrical system based on printed circuit board
 Water separating fuel filter

Undercarriage

Slew ring in oil bath
 Hydraulic track tensioner
 Derailing shields, 3 per side
 Eyes for towing and tying, 4 pcs

Superstructure

Counterweight 7 300 kg
 Access way with ladder

Safety and comfort

Safety bar to prevent accidental actuation via levers and pedals
 Hose rupture valves on the boom cylinders
 Overload alarm
 Working lights(halogen):
 4 front
 1 rear
 Interior lighting in cab and engine compartment
 Rear-view mirrors:
 3 exterior
 Cab heating
 Filtered air intake
 Ergonomic, electrically heated operator's seat with seat belt
 Skylight of special plastic
 Sliding side window in cab door
 Emergency exit through rear window
 Tinted window glass (clear front)
 Interior sun visor
 Upper and lower windscreen wipers with intermittent function

Windscreen washer
 Electric horn
 Silencer with spark arrester
 Oil draining cock on the engine
 Selectable slew holding brake automatics

Hydraulic system

Float position on boom
 3 variable axial piston pumps
 Mode Selector
 Power Boost (HLD)
 Control levers with four switches each
 Hydraulic cylinders with internal end dampening
 Slew priority
 Two speed travel motors with brake valves and brakes of multi-disc type
 Return filter of full flow type 13 µm (abs), 2 000 h exchange interval
 Pressure relief system (Servo accumulator)
 Hydraulically driven, thermostatically controlled cooling fan for the hydraulic oil cooler
 Overspeed protection

Digging equipment

Spherical steel link bearings in all large pivot points
 Safety lifting hook – 14 tons
 Friction-welded piston rod eyes
 Attachment points for extra hydraulics

ALTERNATIVE EQUIPMENT

Undercarriage

Top rollers
 Skid rails

Track shoes

600/700/800/900 mm track shoes with triple grousers and mud holes

Digging equipment

Booms
 6,0 m monobloc
 7,0 m monobloc

Dipper arms

2,2 m (Mass Excavation)
 2,4 m
 2,9 m
 3,5 m
 4,1 m

Buckets

Pin-on buckets and buckets for quickfit S3

GP-bucket	Rock bucket (RB)
2 800 l	2 000 l
2 600 l	1 800 l
2 400 l	1 600 l
2 300 l	
2 100 l	
1 900 l	

Pin-on bucket

GP-bucket (Mass excavation)
 3 000 l

Hydraulic quickfit S3

(weight: 300 kg)

OPTIONAL EQUIPMENT *(Standard on certain markets)*

Engine and electrical system

Diesel-powered cab and engine heater with digital timer
 Electric engine heater, 220 V
 Protective net in front of the cooler
 Alternator 80 A
 Oil bath filter for improved filtering of the intake air
 Coolant filter

Undercarriage

Lockable storage box

Safety and comfort

Protective net for windscreen
 Protective bars for skylight (FOPS 3 449-approved)
 Protective cab roof (FOGS ISO 10 262-approved)
 Fire extinguisher
 Rotating warning beacon
 Extra headlights on boom
 Hydraulically powered fuelling pump, 60 l/min with overfilling protection
 Extra circulation pump for heating system – interval heating
 Extra hose rupture valve – dipper arm cylinder
 Exterior sun visor

Rear window jalousie
 Air conditioning
 Microfilter for cab
 Food heater
 Radio with tape player
 Tool kit
 Service walk
 Travel alarm
 Vandal protection

Hydraulic system

Biodegradable hydraulic oil
 Hydraulic equipment for:
 A. Slope bucket/rotator
 B. Hammer/shears/grab/clam shell
 C. Quickfit
 D. Hand tool
 E. 4th working pump

Under our policy of continuous product improvement, we reserve the right to change specifications and design without prior notice. The illustrations do not necessarily show the standard version of the machine.

VOLVO

**Volvo Construction
 Equipment Group**

Ref. No. 21 3 430 0101 English global
 Printed in Sweden 98.06 – 4,0 EXC
 AB Lunda-kopia, Lund 1998