

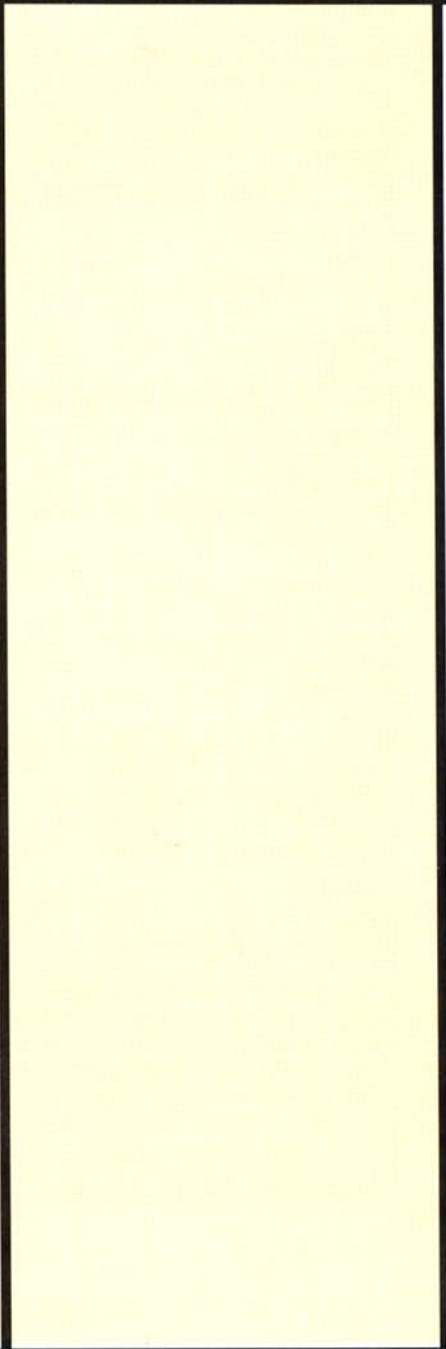

Åkerman Materials handling

International 11

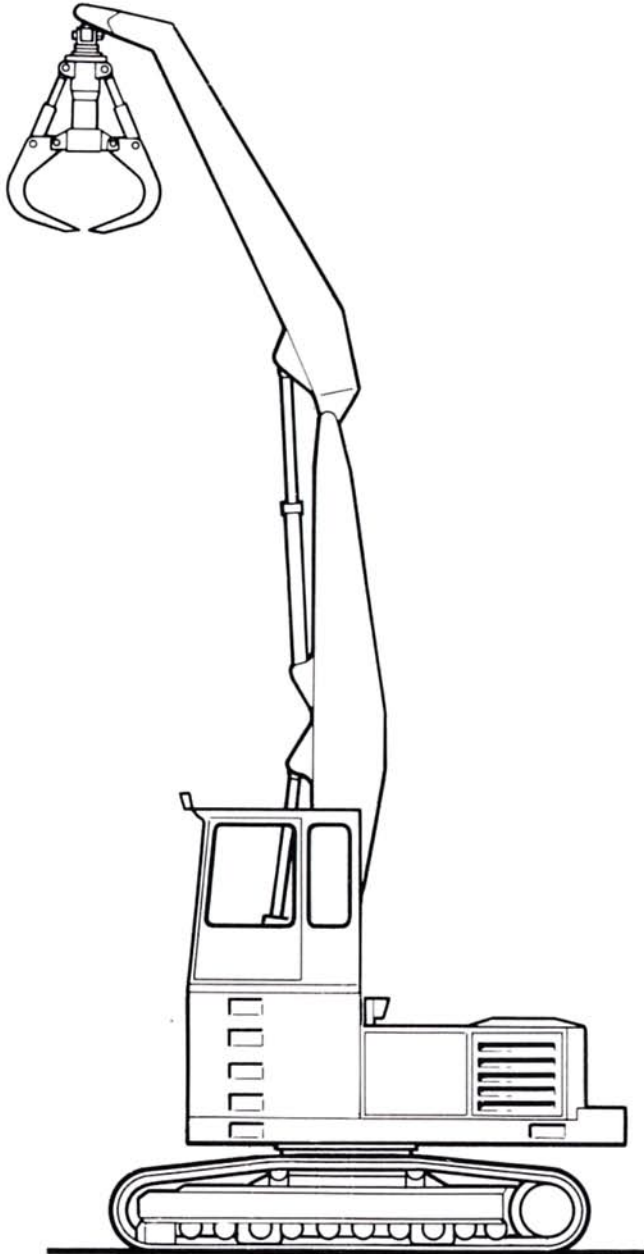

ÅKERMAN

BASE MACHINE



DIESEL ENGINE

VOLVO engine.....Type
The engines are turbocharged 6-cylinder, 4-stroke diesel engines with water cooling and direct injection.

Output.....kW (HP)
(According to ISO 3046, DIN 6271)

Atrpm

Cylinder diametermm

Piston strokemm

Stroke volumedm³

The engines are equipped with electric starter elements to facilitate starting in cold weather.



ELECTRIC SYSTEM, 24V

A.C. Generator.....V/A

Batterypcs. (V)

Battery capacityAh



HYDRAULIC SYSTEM

Pump 1 slewing pump (pressure controlled)

Max. pressure.....MPa (bar)

Max. flowl/min

Pumps 2 and 3 (power and pressure controlled)

Max. pressure.....MPa (bar)

Max. flowl/min

Pump 2 and 3 with HLD

Max. pressure.....MPa (bar)

Pump 4 (for lift magnet generator)

Max. pressure.....MPa (bar)

Max. flowl/min

Servo pump

PressureMPa (bar)

Flowl/min

Steering pump

PressureMPa (bar)

Flowl/min



SLEW SYSTEM

The superstructure is slewed by an axial piston motor. Cab lock, slew gearbox and slew drive shaft are geared between the slew motor and the inner tooth race of the slew ring. Slewing ring runs in sealed oil bath.

Slew speed.....rpm

	H10MB	H10BLC	H14BLC	H16D
TD61ACE	TD61ACE	TD61ACE	TD71ACE	TD100G
Output	122 (166)	122 (166)	154 (209)	192 (262)
At	2100	2100	2000	1700
Cylinder diameter	98.43	98.43	104.77	120.65
Piston stroke	120	120	130	140
Stroke volume	5.48	5.48	6.73	9.6
A.C. Generator	28/55	28/55	28/45	28/45
Battery	4 (12)	4 (12)	4 (12)	2 (12)
Battery capacity	2 x 60	2 x 60	2 x 60	160
Pump 1 Max. pressure	26 (260)	26 (260)	26 (260)	25 (250)
Pump 1 Max. flow	88	88	110	151
Pumps 2 and 3 Max. pressure	26 (260)	26 (260)	26 (260)	26 (260)
Pumps 2 and 3 Max. flow	2 x 142	2 x 142	2 x 170	2 x 245
Pumps 2 and 3 with HLD Max. pressure	30 (300)	30 (300)	30 (300)	30 (300)
Pump 4 Max. pressure	*	*	*	*
Pump 4 Max. flow	*	*	*	*
Servo pump Pressure	6.5 (65)	6.5 (65)	6.5 (65)	6.5 (65)
Servo pump Flow	21	21	20	17
Steering pump Pressure	9.0 (90)	-	-	-
Steering pump Flow	20	-	-	-
Slew speed	8.1	8.0	6.0	6.2

* Due to generator type and size.

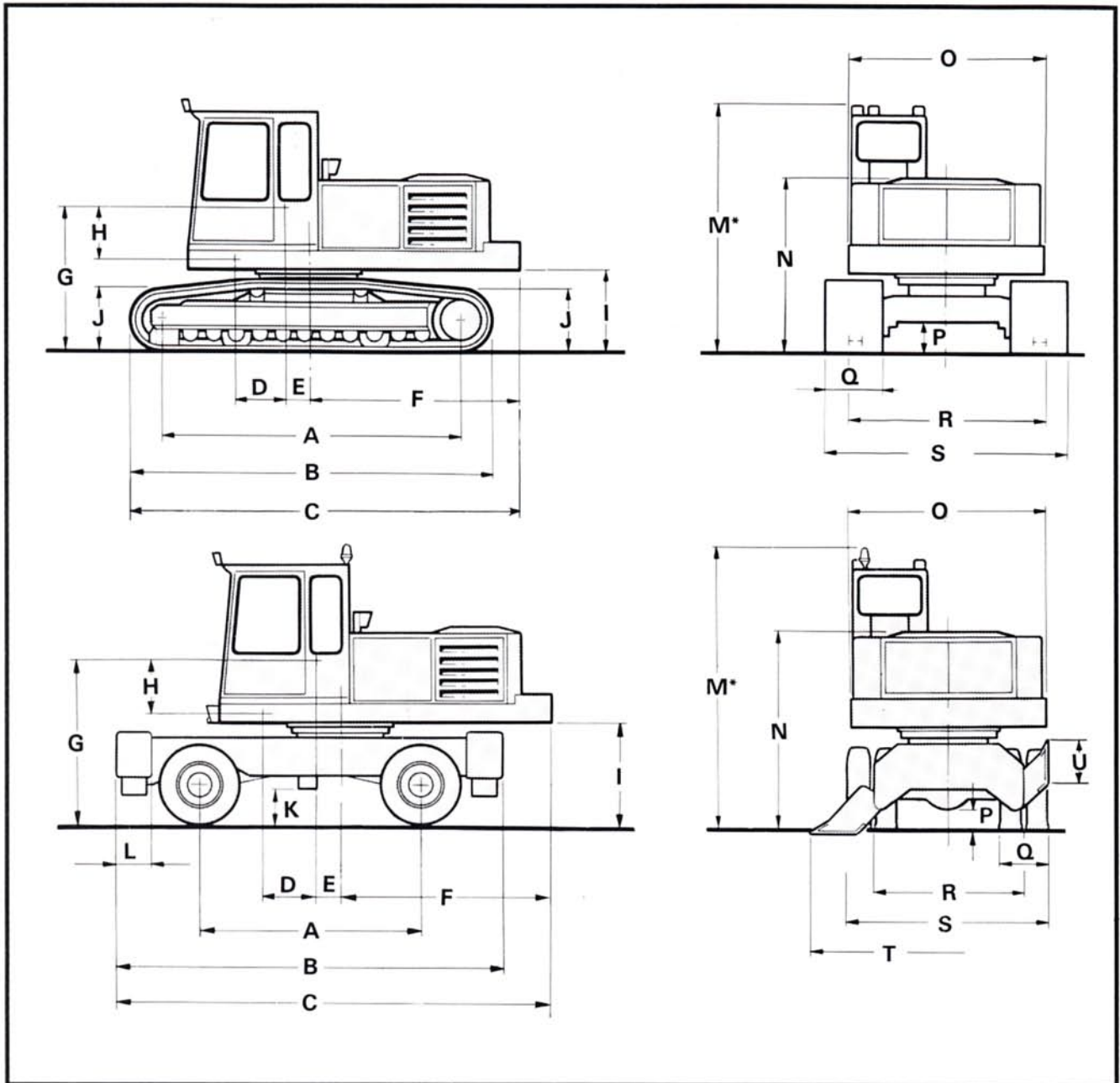

	H10MB	H10BLC	H14BLC	H16D		H10MB	H10BLC	H14BLC	H16D
A	2.78m	3.73m	4.21m	4.05m	K	0.44m			
B	4.92m	4.53m	5.13m	5.07m	L	0.45m			
C	5.59m	4.95m	5.72m	6.16m	M*	3.53m	3.15m	3.31m	3.49m
D	0.65m	0.65m	0.54m	0.62m	N	2.46m	2.24m	2.36m	2.62m
E	0.32m	0.32m	0.36m	0.44m	O	2.49m	2.49m	2.75m	2.90m
F	2.68m	2.68m	3.16m	3.62m	P	0.33m	0.41m	0.42m	0.46m
G	2.08m	1.83m	2.10m	2.33m	Q	0.60m	0.65m	0.75m	0.70m
H	0.65m	0.65m	0.78m	0.82m	R	1.90m	2.52m	2.65m	2.80m
I	1.27m	1.02m	1.12m	1.02m	S	2.47m	3.00m	3.20m	3.30m
J		0.82m	0.94m	1.02m	T	3.33m			
					U	0.53m			

M*: All Åkerman MHE machines can also be delivered with 600 or 1220 mm elevated cab.

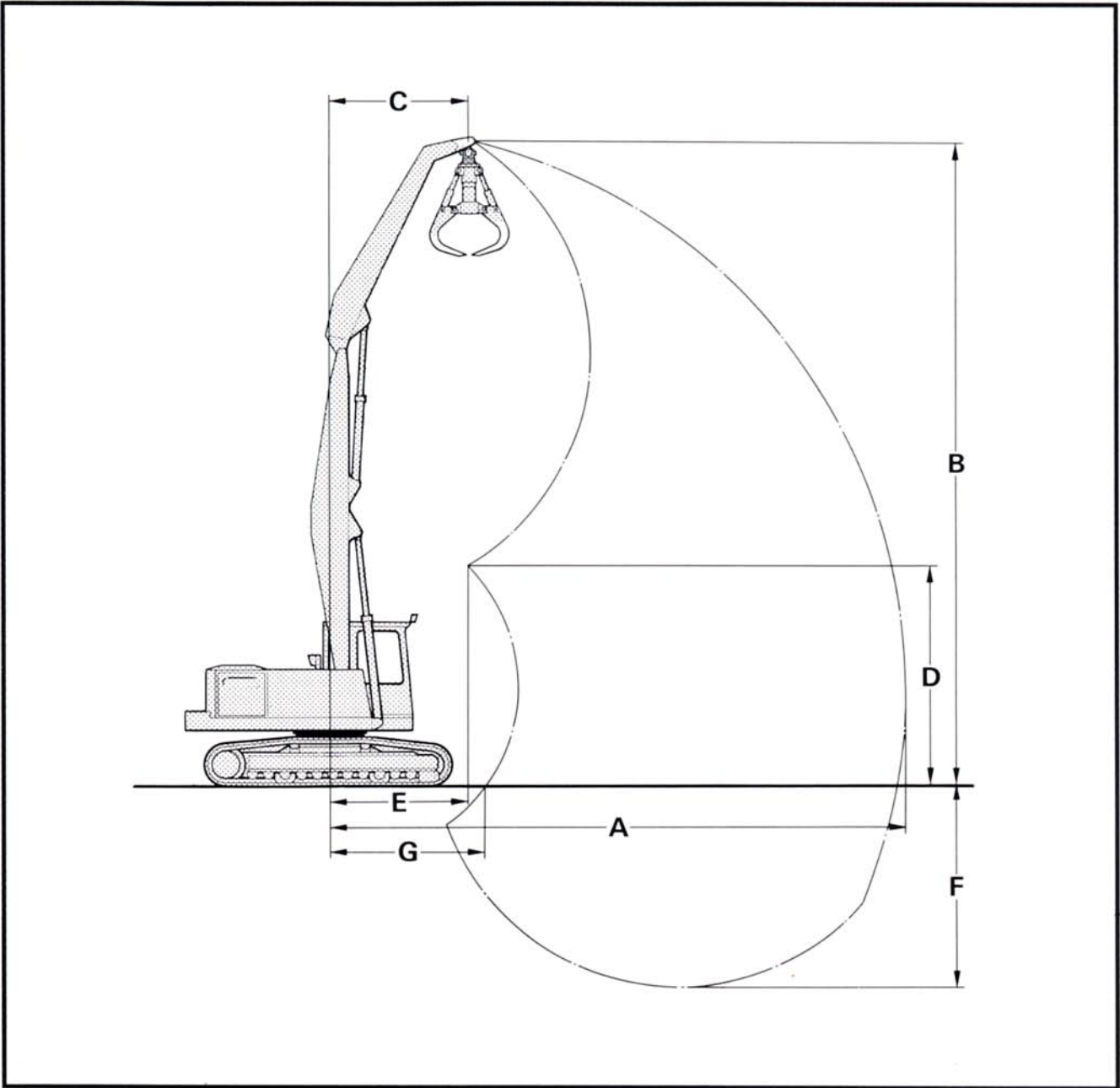

	H10MB	H10BLC	H14BLC	H16D
A Max. reach, slewing centre-dipper pin	10.3m	10.3m	12.8m	15.2m
B Max. height, ground-dipper pin.....	11.8m	11.5m	14.3m	16.5m
C Distance from slewing centre-dipper pin at pos. B	2.6m	2.6m	2.7m	4.4m
D Max. height, ground-dipper arm pin boom at max lift, dipper folded	4.2m	4.0m	4.9m	5.3m
E Distance from slewing centre-dipper arm pin at pos. D	2.5m	2.5m	3.0m	4.2m
F Max. depth, ground-dipper pin.....	3.4m	3.6m	5.3m	6.7m
G Min. reach, slewing centre-dipper arm pin at ground level	2.6m	2.8m	3.6m	4.6m

NOTE: The dimensions in the table show the position of the dipper arm top.

LIFTING CAPACITY

MAX LOAD IN DIPPER ARM TOP-kg. = 100% OF THE TIPPING LOAD
 A = Height of dipper arm top-m. B = Reach of load from centre-m.

H10MB

360°

A \ B	4.0	5.0	6.0	7.0	8.0	9.0	10.0	11.0	Max. reach
11	7230*	5840*							5840*/B = 5.0
10		6940*	5920*						4940*/B = 6.6
9		6710*	6190*	5730*					4740*/B = 7.6
8		6610*	6090*	5670*	5120				4310*/B = 8.5
7		6720*	6150*	5680*	5130	4210			4170 /B = 9.1
6		7030*	6340*	5780*	5100	4220			3810 /B = 9.6
5	8120*	7510*	6630*	5950*	5040	4190	3550		3550 /B = 10.0
4	9820*	8140*	7000*	6090	4960	4140	3510		3420 /B = 10.2
3	11000*	8770*	7360*	5940	4870	4080	3480		3290 /B = 10.4
2	11860*	9270*	7280	5800	4770	4020	3440		3270 /B = 10.4
1	6910*	9290	7080	5660	4680	3960	3410		3290 /B = 10.3
0	5690*	9070	6920	5550	4610	3910	3390		3320 /B = 10.2
-1	5890*	8680*	6810	5480	4560	3880			3290*/B = 9.9
-2	6590*	7730*	6490*	5440*	4500*	3530*			2960*/B = 9.5
-3		6410*	5450*	4530*	3600*				3350*/B = 8.3

H10BLC

360°

A \ B	4.0	5.0	6.0	7.0	8.0	9.0	10.0	11.0	Max. reach
11	6990*								6300*/B = 4.5
10		6790*	5540*						5250*/B = 6.2
9		6770*	6240*	5010					4610 /B = 7.4
8		6620*	6100*	5080	4070				3850 /B = 8.3
7		6680*	6120*	5080	4100	3380			3380 /B = 9.0
6		6930*	6280*	5030	4080	3360			3090 /B = 9.5
5	7870*	7380*	6260	4950	4030	3340			2870 /B = 9.9
4	9520*	7970*	6090	4840	3960	3300	2790		2720 /B = 10.2
3	10710*	7690	5880	4700	3870	3250	2760		2650 /B = 10.3
2	10160	7340	5670	4570	3780	3190	2730		2590 /B = 10.4
1	7840*	7040	5480	4440	3690	3130	2700		2570 /B = 10.4
0	5790*	6810	5320	4330	3620	3080	2670		2620 /B = 10.2
-1	5780*	6670	5220	4250	3560	3050	2680		2680 /B = 10.0
-2	6380*	6610	5160	4210	3530	3040			2830 /B = 9.6
-3	7290*	6600	5140	4200	3530				3190*/B = 8.7

Loads marked with an asterisk (*) are limited by the hydraulic lifting capacity. Other loads limited due to machine stability.
 Working pressure with HLD = 300 bar (30 MPa)

LIFTING CAPACITY

MAX LOAD IN DIPPER ARM TOP-kg. = 100% OF THE TIPPING LOAD

A = Height of dipper arm top-m. B = Reach of load from centre-m.

H14BLC

360°

A \ B	4.0	5.0	6.0	7.0	8.0	9.0	10.0	11.0	12.0	Max. reach
12			7020*	6170*	4820*					4820*/B = 8.0
10			7350*	7010*	6740*	5540	4210*			4210*/B = 10.0
8			7510*	7110*	6700	5540	4650	3920		3690 /B = 11.4
6		8610*	8410*	7730*	6480	5390	4550	3880	3330	3250 /B = 12.2
4	13930*	11580*	9370	7460	6120	5130	4370	3760	3260	2980 /B = 12.7
2		10940	8500	6880	5720	4840	4160	3620	3170	2890 /B = 12.8
0	3910*	8450*	7860	6410	5380	4590	3980	3490	3090	2870 /B = 12.7
-2	5020*	7920*	7560	6160	5180	4440	3870	3420	3070	3020 /B = 12.2
-4	6630*	9260*	7520	6120	5140	4420	3870	3460		3440 /B = 11.1
-6										
-8										
-10										
-12										
-14										
-16										

H16D

360°

A \ B	6.0	7.0	8.0	9.0	10.0	11.0	12.0	13.0	14.0	Max. reach
14		9110*	8270*	6980*						6060*/B = 9.5
12			8630*	8260*	7890*	6560*				5320*/B = 11.6
10			8570*	8170*	7820*	6840	5920	4970*		4800*/B = 13.1
8		9590*	8980*	8460*	7850	6770	5890	5160	4530	4500 /B = 14.1
6	10950*	10730*	9810*	8890	7600	6580	5760	5080	4500	4170 /B = 14.7
4	14160*	12070	9990	8460	7280	6340	5580	4950	4430	3950 /B = 15.1
2	13760	11200	9380	8010	6940	6090	5400	4820	4340	3870 /B = 15.2
0	12350*	10570	8900	7650	6670	5880	5240	4710	4270	3910 /B = 15.0
-2	10810*	10270	8640	7430	6500	5760	5150	4650	4250	4070 /B = 14.6
-4	12080*	10220	8580	7380	6460	5730	5150	4690		4160*/B = 13.8
-6	10130*	9120*	8140*	7190*	6260*	5280*				4800*/B = 11.5
-8										
-10										
-12										
-14										

Loads marked with an asterisk (*) are limited by the hydraulic lifting capacity. Other loads limited due to machine stability. Working pressure with HLD = 300 bar (30 MPa)

EXTRA EQUIPMENT

EXAMPLES OF EXTRA EQUIPMENTS AVAILABLE FOR THE ÅKERMAN MATERIALS HANDLERS.

TOOLS	UNDERCARRIAGE	SAFETY	CAB AND COMFORT OPTIONS
Various grabs.	Wheel: Solid rubber tyres.	Hose rupture valve for dipper arm cylinder ("boom" standard).	Tropical equipment.
Quickfit for grabs.	Articulated outrigger plates.	Beacon.	Air conditioning.
Various magnets.	Widening rings.	Protective grille over cab.	Special filter for polluted air (dust filter standard).
Scrap shears can be mounted on backhoe boom or dipper arm.	Wide base tyres.	Remote control.	Tinted glass.
	Dozerblade. (To replace two of the four outriggers)	Windscreen washers for muddy sites (standard on wheel machines).	Radio with cassette recorder.
	Crawler: Skid rails instead of top rollers.		Electrically heated seat.
	Alternative track plates.		Timer for engine pre-heater.
			Depth meter.
			Electronic speed control.

Specifications and design are subject to change without notice.
Reservations are made for deviations of dimensions and weights listed.

Åkerman Printing M94221/03/92

VME Excavators AB
Box 115, S-241 22 ESLÖV