

VOLVO WHEEL LOADER

L330C

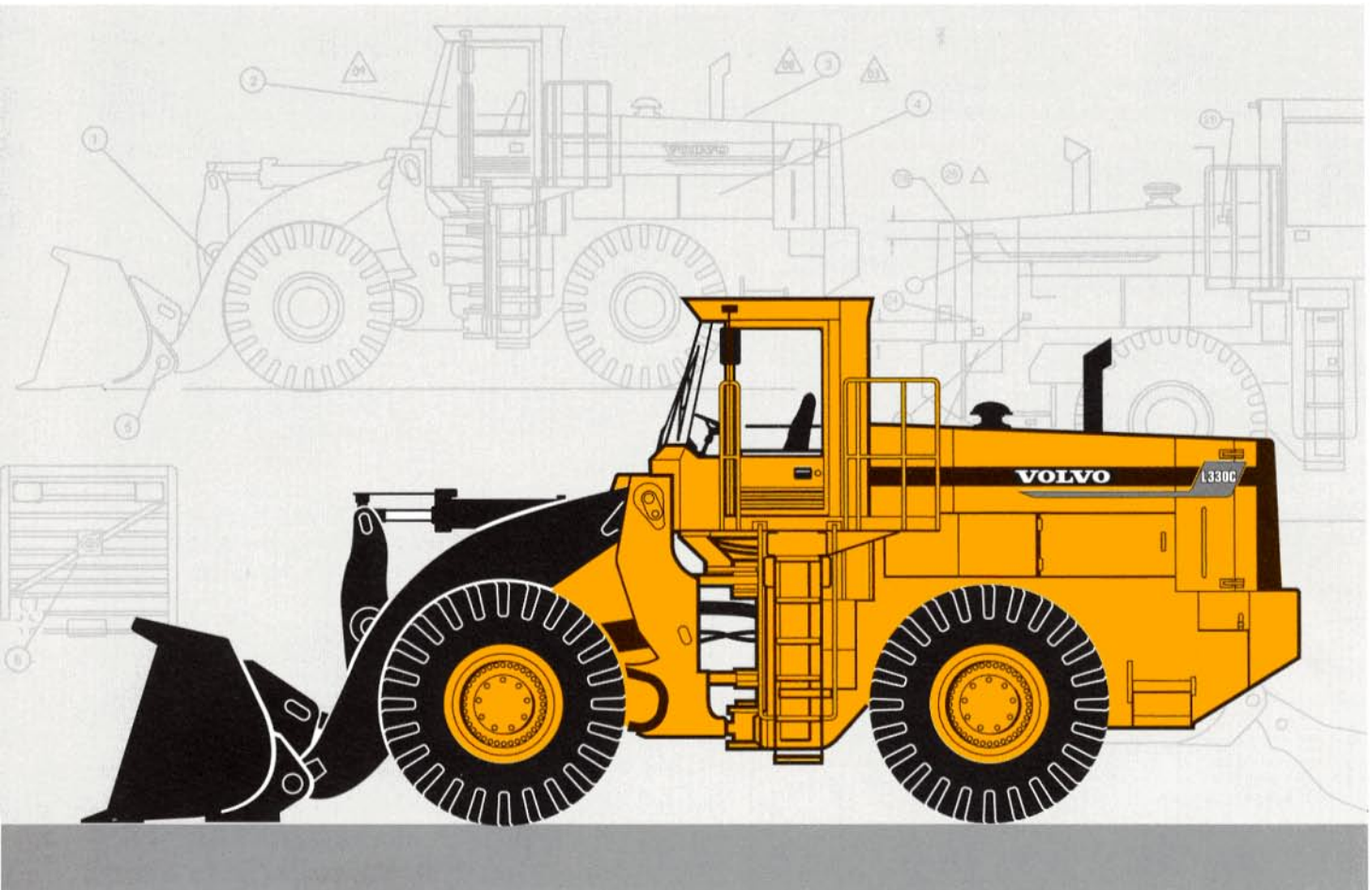

- **Engine output SAE J1349:**
gross 370 kW 503 hp
net 366 kW 498 hp
- **Operating weight:** 46,9–51.6 t
103,400-113,800 lb
- **Buckets:** 6,1-12,7 m³
8.0-16.6 yd³
- **Volvo High Performance Low Emission engine** with excellent low rpm performance. The engine meets all known regulations regarding exhaust emissions for off-road machines until year 2001.
- **Wet disc brakes** – fully sealed, forced oil-cooled, outboard mounted.
- **Posi-Torq** limited-slip differentials in front and rear axles.
- **Care Cab** – pressurized cab with high comfort and safety
- **Contronic monitoring system**
- **Load-sensing hydraulic system** – working and steering hydraulics
- **Pilot-operated working hydraulics**

Optional Equipment

- Long Boom
- Boom Suspension System
- Comfort Drive Control

Other options, see back page

VOLVO



SERVICE

Contronic monitoring system provides information on machine condition, routine maintenance schedules and minimizes time required for troubleshooting.

Service accessibility: Large, easy-to-open engine access doors with gas struts. Hinged radiator grille, fan and condenser. All routine service from ground level or steel platforms

Refill capacities	l	US gal	Refill capacities	l	US gal
Fuel tank	693	183.1	Engine oil	61	16.1
Engine coolant	90	23.8	Transmission	92	24.3
Hydraulic tank	336	88.8	Wheel hubs, ea.	20,8	5.5
Hydraulic system	552	145.8	Differentials, ea.	68,1	18.0
			Midmount bearing	4,7	1.2



ENGINE

Engine delivers high torque and quick response at low rpm even under full load. This contributes to good fuel economy, lower noise, longer life and reduced impact on the environment.

Engine: High performance, low emission, 6 cylinder, in-line, direct-injected, turbocharged and intercooled, 4-stroke diesel engine with wet, replaceable cylinder liners.

Air Cleaning: three stage

Model	Volvo TD 164 KAE	
Output at	30,0 r/s	1800 rpm
SAE J1349 gross	370 kW	503 hp
SAE J1349 net	366 kW	498 hp
Max. torque at	16,7 r/s	1000 rpm
SAE J1349 gross	2370 Nm	1748 lbf ft
SAE J1349 net	2340 Nm	1726 lbf ft
Displacement	16,12 l	984 in ³

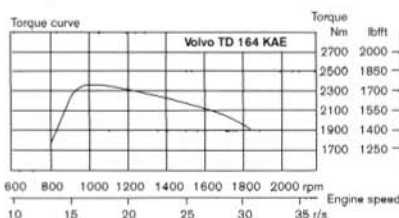

ELECTRICAL SYSTEM

Contronic monitoring system with complete information on the status of the machine's various systems is standard. Electrical system with circuit board, mounted in the cab, is well protected by fuses. Prewired for optional equipment.

Central warning: Central warning lamp for the following functions: engine oil pressure, engine coolant temperature (with buzzer), transmission oil pressure, transmission oil temperature, brake pressure (buzzer), parking brake (buzzer), front axle oil temperature (buzzer), high speed/gear (buzzer), and transmission oil filter. Shut down to idle is standard.

Voltage	24	V
Batteries, series/parallel	4x12	V
Battery capacity, total	240	Ah
Cold cranking capacity	1250	A
Reserve capacity	320	min
Alternator rating	2240	W / 80 A
Starter-motor output	7,5	kW 10.0 hp



DRIVETRAIN

Drivetrain and working hydraulics are well-matched to achieve optimum productivity. Dependable well proven design throughout the whole drivetrain.

Torque converter: Single-stage.

Transmission: Power shift, countershaft design with single lever control. Directional and range modulation provide fast and smooth shifting.

Shifting system: Volvo Automatic Power Shift (APS II) with mode selector.

Axles: Fully floating axle shafts with planetary-type heavy duty hub reductions. Cast-steel axle housing. Fixed front axle and oscillating rear axle. Posi-Torq limited-slip differentials in front and rear axle.

Torque Converter	C9672	
Torque multiplication	2,29:1	
Transmission	C8421H	
Speeds, max forward/reverse	km/h	mph
1 forward/reverse	6,6	4.1
2 forward/reverse	11,6	7.2
3 forward/reverse	19,9	12.4
4 forward only	34,2	21.3

Measured with tires	35/65R33 XLD D1*L-4	
Front axle and rear axle	21D 5568	
Rear axle, oscillation	±12 °	
Total	564 mm	22.2 in



BRAKE SYSTEM

Simple, reliable system ensures high availability and safety. Self-adjusting, forced oil-cooled, wet disc brakes give long service life.

Service brakes: Fully hydraulic operated system with outboard mounted, oil-cooled, wet disc brakes at each wheel. Filtered and cooled oil circulates through each brake when engine is running. Transmission declutch during braking can be pre-selected by a switch on the instrument panel.

Secondary brake: Dual circuit axle-by-axle system. Actuated by service brake pedal. Low pressure alarm. Dead engine braking capability provided by two nitrogen-charged accumulators.

Parking brake: Dry disc type mounted on front axle input shaft. Spring applied, electro-hydraulically released via a switch on the instrument panel. Applies automatically when the key is turned off.

Pump: One variable-flow axial piston pump common with the pilot system.

Standards: The brake system complies with the requirements of ISO 3450, SAE J1473

Brake pressure setting	6,55 MPa	950 psi
Number of discs/wheel	6	
Number of accumulators	2	
Accumulators, volume each	4,0 l	1.06 US gal



STEERING SYSTEM

Low-effort hydrostatic, load-sensing steering system gives short work cycle times. Power-efficient system provides good directional stability and smooth ride and contributes to good fuel economy.

System supply: The steering system is fed by two load-sensing variable-flow axial piston pumps. The pumps will also feed the main hydraulic system, but steering system always has priority.

Cylinders: Double-acting cylinders, with frame mounted rubber cushioned steer stops.

Standards: Steering system complies with ISO 5010 and SAE J6S61

Steering cylinder	2		
Bore	125 mm	4.92 in	
Piston rod diameter	70 mm	2.76 in	
Stroke	493 mm	19.4 in	
Relief pressure	21,5 MPa	3118 psi	
Max. flow	370 l/min	97.75 US gpm	
Articulation	± 35°		



CAB

Care Cab has easy entry and wide door opening. Lined with sound-absorbent material. Sound and vibration-suppressing suspension. Good all-round visibility, large glass areas. Curved windshield of laminated, green-tinted glass. Ergonomically located controls and instruments permit a comfortable operating position.

Instrumentation: All important information is readily visible to the operator. Cab display for Contronic monitoring system.

Heater/defroster/air conditioner: Heating element and air conditioner with filtered fresh air and four-speed fan. Defroster outlets for all windows. Cab air can be recirculated.

Operator's seat: Air suspended, adjustable operator's seat with belt. The seat is mounted on a bracket on the rear wall. The force from the belt is absorbed by the seat rails.

Standards: Tested and approved according to the following standards: ROPS (ISO 3471, SAE J1040), FOPS (ISO 3449, SAE J231). Complies with (ISO 6055) and "Operator Restraint System" (SAE J386).

Emergency exits	2		
Sound level in cab			
as per ISO 6394, max.	74 dB (A)		
Exterior sound level			
ISO 6393	LwA 115 dB (A)		
Ventilation	10 m ³ /min	353 ft ³ /min	
Heating capacity	11 kW	37,500 Btu/h	
Air conditioning capacity	8 kW	27,300 Btu/h	



HYDRAULIC SYSTEM

Load-sensing hydraulics distribute exactly the quantity of oil required for the function used. Load-sensing gives precise control of the hydraulics throughout the lifting range. High pump capacity provides quick and smooth movements.

System supply: Four load-sensing variable-flow axial piston pumps. Steering function always has priority from two of the pumps.

Valve: Twin double-acting 2-spool valves. The main valves are actuated by a pilot valve.

Lift function: The valve has four functions: raise, hold, lower and float. Adjustable inductive/magnetic automatic boom kickout can be switched on and off and is adjustable to any position between maximum reach and full lift height.

Tilt function: The valve has three functions: rollback, hold and dump. Adjustable inductive/magnetic automatic bucket positioner can be switched on and off.

Cylinders: Double-acting.

Filter: Full-flow filtration through 20 micron (absolute) filter cartridge.

Main system			
Relief pressure	21,5 MPa	3118 psi	
Flow	740 l/min	196 US gpm	
at	10 MPa	1450 psi	
and engine speed	30,0 r/s	1800 rpm	

Pilot system			
Relief pressure	3,5 MPa	508 psi	

Cycle times	s		
Raise*	8,5		
Dump*	1,8		
Lower, empty	4,5		
Total cycle time	14,8		

* with load as per ISO 5998 and SAE J818



LIFT-ARM SYSTEM

The Z-bar system is a dependable linkage with good breakout qualities. Ideal for a primary production unit.

Lift cylinder	2		
Bore	230 mm	9.1 in	
Piston rod diameter	120 mm	4.7 in	
Stroke	1170 mm	46.0 in	
Tilt cylinder	2		
Bore	190 mm	7.5 in	
Piston rod diameter	90 mm	3.5 in	
Stroke	808 mm	31.8 in	

OPERATIONAL DATA VOLVO L330C (STANDARD BOOM)

Tires 35/65R33 XLD D1* L-4 Michelin		Heavy duty and material handling							Material handling		
		Straight edge, STE, BOE**	STE with teeth*	STE w/teeth* & wear caps	Spade nose SPN, BOE**	SPN with teeth*	SPN w/teeth* & wear caps	SPN with BOE**	SPN with teeth*	Straight edge, STE BOE**	STE with BOE**
Volume, heaped	m ³ yd ³	6,9 9,0	6,6 8,6	6,9 9,0	6,8 8,9	6,6 8,6	6,8 8,9	7,5 9,8	7,4 9,7	7,3 9,5	8,3 10,9
Volume, struck	m ³ yd ³	5,9 7,7	5,6 7,3	5,9 7,7	5,8 7,6	5,6 7,3	5,8 7,6	6,6 8,6	6,5 8,5	6,3 8,2	7,3 9,5
Bucket weight	kg lb	5030 11,090	4 940 10,890	5 270 11,620	5 640 12,430	5 490 12,100	5 820 12,830	5 890 12,990	5 760 12,700	4 700 10,360	4 940 10,890
Static tipping load, straight	kg lb	35 230 77,670	35 450 78,150	34 720 76,540	34 300 75,620	34 600 76,280	34 020 75,000	33 430 73,700	33 940 74,820	35 470 78,200	34 710 76,520
Static tipping load, at full turn	kg lb	31 000 68,340	31 210 68,810	30 470 67,170	30 040 66,230	30 340 66,890	29 760 65,610	29 230 64,440	29 700 65,480	31 250 68,890	30 500 67,240
Breakout force	kN lbf	467,6 105,120	499,7 112,340	466,8 104,940	372,1 83,650	392,7 88,280	371,4 83,490	346,4 77,870	364,7 81,990	460,3 103,480	420,1 94,440
A	mm ft in	10 080 33'1"	10 320 33'10"	10 360 34'0"	10 470 34'4"	10 720 35'2"	10 760 35'4"	10 620 34'10"	10 870 35'8"	10 100 33'2"	10 260 33'8"
L	mm ft in	7 280 23'11"	7 280 23'11"	7 280 23'11"	7 160 23'6"	7 160 23'6"	7 160 23'6"	7 310 24'0"	7 310 24'0"	7 010 23'0"	7 150 23'5"
J	mm ft in	4 650 15'3"	4 690 15'5"	4 640 15'3"	4 650 15'3"	4 690 15'5"	4 640 15'3"	4 640 15'3"	4 680 15'4"	4 650 15'3"	4 630 15'2"
H	mm ft in	3 660 12'0"	3 510 11'6"	3 480 11'5"	3 410 11'2"	3 260 10'8"	3 220 10'7"	3 310 10'10"	3 160 10'4"	3 650 12'0"	3 540 11'7"
M	mm ft in	1 740 5'9"	1 980 6'6"	1 940 6'4"	2 040 6'8"	2 280 7'6"	2 250 7'5"	2 140 7'0"	2 380 7'10"	1 760 5'9"	1 860 6'1"
N	mm ft in	2 470 8'1"	2 670 8'9"	2 630 8'8"	2 710 8'11"	2 900 9'6"	2 850 9'4"	2 780 9'1"	2 960 9'9"	2 490 8'2"	2 570 8'5"
T	mm ft in	130 5.1"	90 3.5"	140 5.5"	130 5.1"	90 3.5"	140 5.5"	140 5.5"	100 3.9"	130 5.1"	140 5.5"
E	mm ft in	1 300 4'3"	1 200 3'11"	1 300 4'3"	1 610 5'3"	1 520 5'0"	1 620 5'4"	1 730 5'8"	1 640 5'5"	1 320 4'4"	1 440 4'9"
Operating weight	kg lb	48 430 106,770	48 340 106,570	48 670 107,300	49 040 108,110	48 900 107,800	49 230 108,530	49 290 108,660	49 170 108,400	48 100 106,000	48 340 106,570

Counterweight 1 included in operational data. Counterweight 1 may be used in material handling.

* Teeth, Combi-parts C5T9. Dimensions measured to tips of teeth. Other teeth may affect dimensions differently.

** BOE = Bolt-on edges

BUCKET SELECTION CHART

The volume handled varies with the bucket fill and is often greater than indicated by the bucket's ISO/SAE volume. The table shows optimum bucket choice with regard to the material density.

Material	Bucket fill %	Density t/m ³	Density lb/yd ³
Earth	100-115	1,4-1,6	2360-2700
Clay	110-120	1,4-1,6	2360-2700
Sand	100-110	1,6-1,9	2700-3200
Gravel	100-110	1,7-1,9	2870-3200
Rock	75-100	1,5-1,9	2530-3200

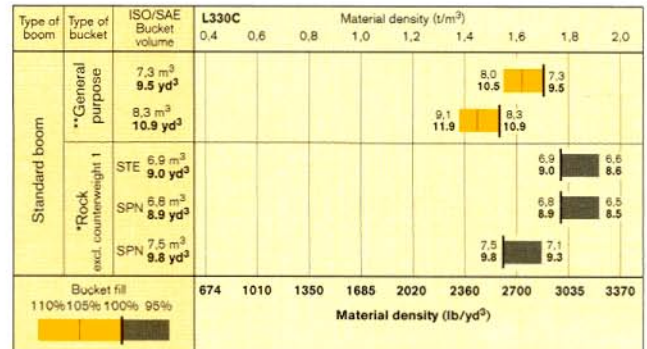

counterweight 1 included

* includes teeth and segments alt. bolt-on edges

** includes bolt-on edges

BUCKET DIMENSIONS

Bucket dimensions		Straight edge, STE, BOE**	STE with teeth*	STE w/teeth* & wear caps	Spade nose, SPN, BOE**	SPN with teeth*	SPN w/teeth* & wear caps	SPN with BOE**	SPN with teeth*	Straight edge, STE BOE**	STE with BOE**
b	mm ft in	1 920 6'4"	2 200 7'3"	2 200 7'3"	2 320 7'7"	2 590 8'6"	2 590 8'6"	2 400 7'10"	2 680 8'10"	1 940 6'4"	2 090 6'10"
c	mm ft in	1 860 6'1"	1 820 6'0"	1 870 6'2"	1 830 6'0"	1 790 5'10"	1 840 6'0"	2 190 7'2"	2 150 7'1"	1 820 6'0"	1 890 6'2"
d	mm ft in	1 490 4'11"	1 770 5'10"	1 770 5'10"	1 910 6'3"	2 180 7'2"	2 180 7'2"	2 000 6'7"	2 270 7'5"	1 530 5'0"	1 680 5'6"
e	mm ft in	3 850 12'8"	3 850 12'8"	3 850 12'8"	3 900 12'10"	3 900 12'10"	3 900 12'10"	3 900 12'10"	3 900 12'10"	3 830 12'7"	3 830 12'7"
v	mm ft in	3 970 13'0"	3 970 13'0"	3 970 13'0"	3 970 13'0"	3 970 13'0"	3 970 13'0"	3 970 13'0"	3 970 13'0"	3 970 13'0"	3 970 13'0"
y	mm ft in	65 2.6"	65 2.6"	65 2.6"	65 2.6"	65 2.6"	65 2.6"	65 2.6"	65 2.6"	65 2.6"	65 2.6"
a, clearance circle	mm ft in	18 100 59'5"	18 300 60'0"	18 310 60'1"	17 990 59'0"	18 190 59'8"	18 200 59'9"	18 070 59'3"	18 280 60'0"	18 110 59'5"	18 190 59'8"

OPERATIONAL DATA & DIMENSIONS (STANDARD BOOM)

Tires 35/65R33 XLD D1* L-4 Michelin

Where applicable, specifications and dimensions are in accordance with ISO 7131, SAE J732, ISO 7546, SAE J742, ISO 5998, SAE J818, ISO 8313.
Changes from the standard configuration may change machine dimensions and operating data. Operating weight is approximate and includes the bucket given in the table, ROPS canopy, cab, all standard equipment and counterweight 1.

B	8 320 mm	27' 4"
C	4 060 mm	13' 4"
D	550 mm	1' 10"
F	4 170 mm	13' 8"
F1	3 840 mm	12' 7"
F2	3 150 mm	10' 4"
F3	40 mm	1.6"
G	2 135 mm	7' 0"
K	5 040 mm	16' 6"
O	66 °	
P	45 °	
R	44 °	
R ₁ *	51 °	
S	57 °	
U	400 mm	1' 4"
V	3 970 mm	13' 0"
X	2 720 mm	8' 11"
Y	3 630 mm	11' 11"
Z	4 140 mm	13' 7"
a ₂	8 250 mm	27' 1"
a ₃	4 620 mm	15' 2"
a ₄	±35 °	

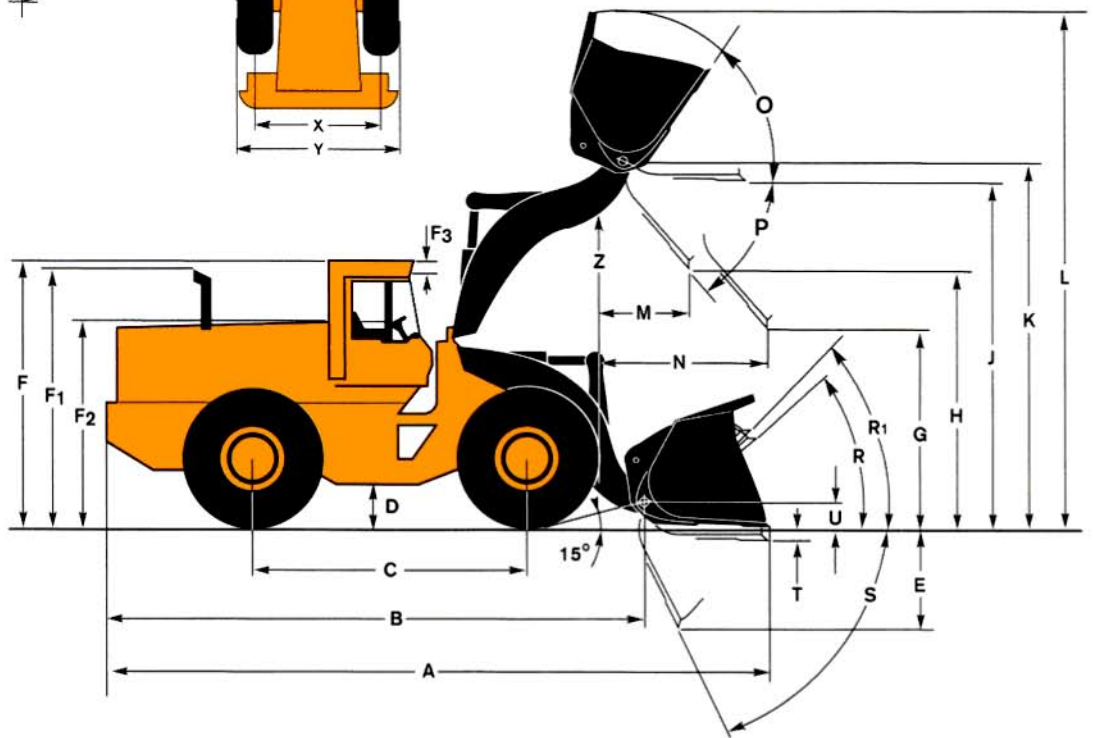
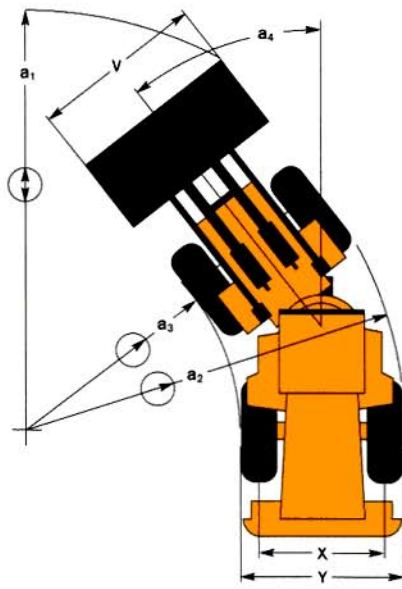

* Carry position SAE

BUCKET DIMENSIONS

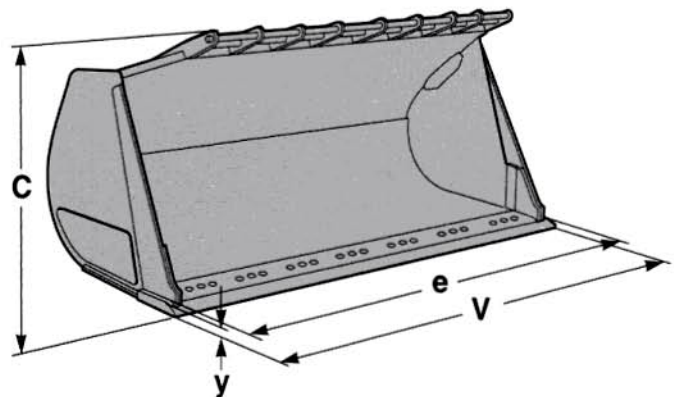
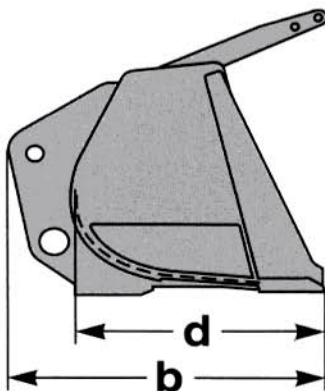

SUPPLEMENTAL OPERATING DATA (STANDARD BOOM)

Tires 35/65R33 XLD D1* L-4 Michelin and counterweight 1

SUPPLEMENTAL OPERATING WEIGHT		Change in operating weight	Change in static tipping load, straight	Change in static tipping load, full turn
Counterweight #1 (removal)	kg	- 1 040	- 2 300	- 2 050
	lb	- 2290	- 5070	- 4 520
ROPS canopy (removal) (for shipping only)	kg	- 760		
	lb	- 1680		
Optional tires:				
35/65-33 (30PR) L-4 Firestone/	kg	+ 990	+ 740	+ 670
	lb	+ 2180	+ 1630	+ 1480
35/65-33 (36PR) L-4 Firestone	kg	+ 785	+ 585	+ 530
	lb	+ 1730	+ 1290	+ 1170
35/65-33 (30PR) L-4 Goodyear	kg	+ 1 480	+ 1 110	+ 1 010
	lb	+ 3260	+ 2440	+ 2220
35/65-33 (30PR) L-5 Firestone	kg	+ 1 470	+ 1 100	+ 1 000
	lb	+ 3240	+ 2425	+ 2205
35/65-33 (30PR) L-5 Goodyear	kg	+ 1 180	+ 880	+ 803
	lb	+ 2600	+ 1940	+ 1770
35/65R33 RL-5K* L-5 Goodyear	kg	+ 640	+ 410	+ 360
	lb	+ 1410	+ 940	+ 790
35/65R33 XLD D2* L-5 Michelin	kg	+ 1230	+ 940	+ 880
	lb	+ 2710	+ 2070	+ 1940

SUPPLEMENTAL OPERATING DIMENSIONS		Change in height dimensions	Change in width over tires	Change in reach fully raised
Optional tires:				
35/65-33 (30PR) L-4 Firestone/	mm	+ 40	- 17	- 15
	in	+ 1.6"	- 0.7"	- 0.6"
35/65-33 (36PR) L-4 Firestone	mm	+ 10	- 7	- 12
	in	+ 0.4"	- 0.3"	- 0.5"
35/65-33 (30PR) L-4 Goodyear	mm	+ 40	- 25	- 15
	in	+ 1.6"	- 1.0"	- 0.6"
35/65-33 (30PR) L-5 Firestone	mm	+ 10	- 13	- 12
	in	+ 0.4"	- 0.5"	- 0.5"
35/65-33 (30PR) L-5 Goodyear	mm	+ 20	- 9	- 12
	in	+ 0.8"	- 0.4"	- 0.5"
35/65R33 RL-5K* L-5 Goodyear	mm	+ 15		
	in	+ 0.6"		
35/65R33 XLD L-5 Michelin	mm	+ 33	+ 7	
	in	+ 1.3"	+0.3"	

SUPPLEMENTAL SHIPPING DIMENSIONS		Height dimensions without ROPS canopy	Height dimensions
Lower center hinge – top of cab	mm	3 560	
	ft in	11' 8"	
Rear frame – top of cab	mm	3 550	
	ft in	11' 8"	
Bottom of planetary – top of cab	mm	3 530	
	ft in	11' 7"	
Bottom of differential – top of cab	mm	3 500	
	ft in	11' 6"	
Bottom of wooden wheels – top of cab	mm	3 730	
	ft in	12' 3"	
Bottom of wooden wheels – planetary	mm		200
	in		8"
Bottom of wooden wheels – differential	mm		235
	in		9.2"

SUPPLEMENTAL OPERATING DATA (LONG BOOM)

Tires 35/65R33 XLD D1* L-4 Michelin and counterweight 1 & 2

SUPPLEMENTAL OPERATING WEIGHT		Change in operating weight	Change in static tipping load, straight	Change in static tipping load, full turn
Counterweight #1 (removal) (for shipping only)	kg	-1 040		
	lb	- 2 290		
Counterweight #2 (removal)	kg	- 1 040	- 2 140	- 1 900
	lb	- 2 290	- 4 720	- 4190
ROPS canopy (removal) (for shipping only)	kg	+ 760		
	lb	+ 1 680		
Optional tires: 35/65-33 (30PR) L-4 Firestone/	kg	+ 990	+ 690	+ 630
	lb	+ 2 180	+ 1 520	+ 1390
35/65-33 (36PR) L-4 Firestone	kg	+ 785	+ 545	+ 495
	lb	+ 1 730	+ 1 200	+ 1090
35/65-33 (30PR) L-4 Goodyear	kg	+ 1 480	+ 1 030	+ 940
	lb	+ 3 260	+ 2 270	+ 2070
35/65-33 (30PR) L-5 Firestone	kg	+ 1 470	+ 1 025	+ 930
	lb	+ 3 240	+ 2 260	+ 2050
35/65R33 RL-5K* L-5 Goodyear	kg	+ 1 180	+ 820	+ 745
	lb	+ 2 600	+ 1 810	+ 1640
35/65 R33 XLD D2* L-5 Michelin	kg	+ 640	+ 370	+ 330
	lb	+ 1 410	+ 940	+ 790
35/65 R33 XMINE D2 L-5 Michelin	kg	+ 1 230	+ 770	+ 700
	lb	+ 2 710	+ 2 070	+ 1 940

SUPPLEMENTAL OPERATING DIMENSIONS		Change in height dimensions	Change in width over tires	Change in reach fully raised
Optional tires:				
35/65-33 (30PR) L-4 Firestone/	mm	+ 40	- 17	- 15
	in	+ 1.6"	- 0.7"	- 0.6"
35/65-33 (36PR) L-4 Firestone	mm	+ 10	- 7	- 12
	in	+ 0.4"	- 0.3"	- 0.5"
35/65-33 (30PR) L-4 Goodyear	mm	+ 40	- 25	- 15
	in	+ 1.6"	- 1.0"	- 0.6"
35/65-33 (30PR) L-5 Firestone	mm	+ 10	- 13	- 12
	in	+ 0.4"	- 0.5"	- 0.5"
35/65R33 RL-5K* L-5 Goodyear	mm	+ 20	- 9	- 12
	in	+ 0.8"	- 0.4"	- 0.5"
35/65R33 XLD D2* L-5 Michelin	mm	+ 15		
	in	+ 0.6"		
35/65R33 XMINE D2 L-5 Michelin	mm	+ 33	+ 7	
	in	+ 1.3"	+ 0.3"	

SUPPLEMENTAL SHIPPING DIMENSIONS		Height dimensions without ROPS canopy	Height dimensions	
Lower center hinge – top of cab	mm	3 560		
	ft in	11'8"		
Rear frame – top of cab	mm	3 550		
	ft in	11'8"		
Bottom of planetary – top of cab	mm	3 530		
	ft in	11'7"		
Bottom of differential – top of cab	mm	3 500		
	ft in	11'6"		
Bottom of wooden wheels – top of cab	mm	3 730		
	ft in	12'3"		
Bottom of wooden wheels – planetary	mm		200	
	in		8"	
Bottom of wooden wheels – differential	mm		235	
	in		9.2"	

STANDARD EQUIPMENT

Service and maintenance

Engine oil remote drain and fill
Lubrication manifolds, ground accessible
Radiator remote drain and fill
Transmission remote drain and fill
Pressure test ports: transmission and hydraulic, quick connect, grouped on console for easy access
Fan, hydraulic driven, swing out
Grille, rear, swing out

Engine

Air cleaner, dry type, dual element, with exhaust aspirated precleaner
Coolant filter
Coolant level sight gauge
Engine intake manifold pre-heater
Exhaust rain protection
Flat-round radiator
Low emission

Electrical System

24 volt – prewired for optional equipment
Alternator, 24 Volt, 80 Amp
Battery disconnect switch, lockable
Back-up alarm, acoustic
Gauges:
• engine temperature
• fuel level
• transmission temperature
Hourmeter
Horn, electric
Lights:
• instrument lighting
• parking lights
• stop/tail combination (2 rear)
• turn signals with hazard warning switch
• working lights, 60 watt halogen (6 front and 2 rear)

Contronic Monitoring System, ECU

Engine shut down to idle
Brake test
Neutral start feature
Test function for Warning & monitoring lights
Information panel (Contronic): start configuration, setting language and units, operating hours, general operating information, stop watch/trip meter, cycle counter, service intervals engine electrical system transmission axles/brakes hydraulics
Central Warning (light with buzzer): engine oil pressure, engine coolant temperature (buzzer), transmission oil pressure, transmission oil temperature, brake system pressure, parking brake applied and transmission in forward or reverse (buzzer), front axle oil temperature (buzzer), hydraulic oil temperature, high speed/gear (buzzer), transmission oil filter, fan circuit.
Warning and Monitoring Lights:
• engine oil pressure
• engine coolant temperature
• air cleaner restriction
• alternator malfunction
• working lights
• direction indicator
• hazard warning flasher
• transmission oil pressure
• transmission oil temperature
• brake system pressure
• parking brake applied
• front axle oil temperature
Neutral start feature
Test function for monitor and warning lights during start-up

Drivetrain

Countershaft transmission with directional and range modulation
Single lever control
Automatic Power Shift (APS II)
Operator controlled declutch
Kickdown to 1st switch on shift lever and hydraulic console
Switch, forward/reverse at hydraulic controls
Brakes, full hydraulic, wet disc, continuous oil-cooled, 4 wheel dual-circuit, axle by axle
Secondary brake system, accumulator supplied
Differentials: Posi-Torq limited-slip front and rear

Tires

35/65-33 (30 PR) L-4 FS

Cab and ROPS Canopy

ROPS Canopy (ROPS, SAE J1040, ISO 3471) FOPS, SAE J231, ISO 3449)
Cab (ROPS, SAE J1040, ISO 3471)
Acoustical lining
Air conditioner, 7kW, 24,000 Btu/h
Ashtray
Cigarette lighter
Door lockable (left side access)
Dual brake pedals
Heater/defroster/pressurizer 11 kW (37,500 Btu/h) with four speed blower fan
Filtered air for cab
Floor mat
Instrument panel with symbols
Interior light
Mirror, rearview interior
Mirror, rearview, exterior (2)
Operator seat, ISRI, airsuspended, heated
Safety glass, tinted
Retractable seat belt (SAE J386)
Sliding window door
Steering wheel, telescoping, adjustable tilt

Storage compartment
Sun visor
Windshield wiper and washer, front and rear
Window openable, right-hand side
Wiper, intermittent, front
Cab access steps, hand rails, service platforms with anti-skid surfaces (SAE J185)

Hydraulic System

Main, load-sensing valves, 2 spool, pilot-operated
Pilot valve, 3 spool
Four variable-flow axial piston pumps (2 have steering priority)
Boom and bucket control levers, fingertip
Boom lever detents
Boom lowering system
Boom kickout, automatic, adjustable
Bucket lever detents
Bucket leveler, automatic, adjustable
Control lever safety latch
Hydraulic pressure test ports, quick connect
Hydraulic fluid level sight gauge
Hydraulic oil cooler

External

Drawbar with pin
Fenders
Mudflap; front
Fuel fill strainer
Isolation mounts: cab, engine, transmission, radiator
Lifting lugs
Side panels, engine hood
Steering frame lock
Tie-down locations
Vandalism lock, provision for, batteries, engine coolant, fuel, hydraulic fluid, transmission/torque converter fluid, engine side panels
Boom to bucket pins with dual double-tapered roller bearings

OPTIONAL EQUIPMENT

Service and maintenance

Tool kit
Tool box, lockable
Automatic lubrication system

Engine equipment

Engine block heater, 120 V US
Engine block heater, 240 V US

Electrical system

Rotating beacon
Working lights rear, extra
Battery for extrem cold weather

Tyres and rims

35/65-33 (36 PR) L4 FS

35/65-33 (42 PR) L4 FS
35/65-33 (30 PR) L5 FS
35/65-33 (30 PR) L4 GY
35/65-33 (30 PR) L5 GY
35/65R33 RL-5K* L5 GY
35/65R33 XLD D1* L4 MI
35/65R33 XLD D2* L5 MI
35/65R33 X MINE D2 L5 MI
Wood protected rims

Cab

Armrest (left) for ISRI operator seat
Radio installation kit
Hip belt 3in
Operator seat, ISRI, spring suspended, heated

Hand throttle, lockable
Sliding window right side

Hydraulic system

Attachment locking, without bracket
Biodegradable hydraulic fluid
Boom Suspension System
3rd hydraulic control
4th hydraulic control

External equipment

Counterweight 1* - 2 x 520 kg (2 x 1145 lb)
Counterweight 2 - 2 x 520 kg (2 x 1145 lb)
Rear fenders, swing-out
* required with Long Boom

Protective equipment

Guards for stop/tail lights
Windshield guard
Guards for headlights front
Guards for working lights rear
Window guards, side and rear window
Belly guard front and rear
Under cab guard
Radiator sand grid
Lift cylinders hose guard

Other equipment

Comfort Drive Control, CDC
Long boom
Secondary steering

Under our policy of continuous product improvement, we reserve the right to change specifications and design without prior notice. The illustrations do not necessarily show the standard version of the machine.

VOLVO

Volvo Construction Equipment
North America Inc.

One Volvo Drive, Asheville, N.C. 28803-3447
Tel: 828-650-2090, Fax: 828-650-2508

Ref. No. 22 2 669 2268
Printed in USA 06/99 - 5,0
Blitmore Press, Asheville, NC

WLO