



Volvo BM L180

- **Engine output gross:**
SAE J1349 211 kW
(289 hp)
- **Operating weight:**
23.4 t
(51,600 lb)
- **Buckets:**
4,2-4,6 m³
(5.5-6.0 yd³)

The high-capacity loader for the tough jobs

- **Torque Parallel Linkage** –
Powerful lift-arm system with:
 - unique breakout moment
 - excellent parallel lift-arm action
 - high lift height and long reach
- **Direct-injected, turbocharged Volvo diesel**
- **Automatic Power Shift**
- **Enclosed wet oil-cooled brakes**
- **Care Cab** – the cab with great comfort and safety
- **Precision steering with good stability and maneuverability**
 - **Contronic** monitoring system
 - **Pilot-operated hydraulic system**
 - **Hydraulic attachment bracket**



VOLVO BM



ENGINE

Volvo TD 122, a 6-cylinder, in-line, direct-injection, 4-stroke, turbocharged diesel engine with wet, replaceable cylinder liners.

Air cleaning: Air cleaning in three stages

1. Multi cyclone cleaner with automatic particle ejector
2. Paper filter with restriction warning light on instrument panel
3. Replaceable safety filter

Make	Volvo			
Model	TD 122			
Output, gross at	rps	rpm	33,3	2000
SAE J1349	kW	hp	211	289
Flywheel output at	rps	rpm	33,3	2000
SAE J1349	kW	hp	202	275
DIN 70020 / 6271	kW	hp	202	275
Max. torque at	rps	rpm	18,3	1100
SAE J1349 Gross	N•m	lbf ft	1390	1025
SAE J1349 Net	N•m	lbf ft	1380	1018
DIN 70020 / 6271	N•m	lbf ft	1380	1018
No. of cylinders	6			
Displacement, total	l	in ³	12,0	733
Bore	mm	in	130,17	5.12
Stroke	mm	in	150	5.90
Compression ratio	15:1			



ELECTRICAL SYSTEM

Contronic monitoring system with extended function surveillance. Solid-state electrical distribution box. The electrical system is well-protected by fuses. Prewired for optional equipment.

Central warning:

Central warning lamp for following functions: engine oil pressure, brake pressure, parking brake (audible alarm also), engine temperature (audible alarm also), transmission temperature, transmission oil pressure, temperature front and rear axle/brake (audible alarm also), secondary steering (optional equipment), transmission hydraulic oil filter restriction.

Voltage	V	24		
Batteries	V	2x12		
Battery capacity	Ah	2x140		
Alternator rating	W / A	1680 / 60		
Starter motor output	kW	hp	6,6	9.0



SERVICE REFILL CAPACITIES

Crankcase	l	US gal	33	8.7
Fuel tank	l	US gal	339	89.6
Cooling system	l	US gal	80	21.1
Transmission total	l	US gal	48	12.7
Front axle, total	l	US gal	46	12.2
Rear axle, total	l	US gal	46	12.2
Hydraulic system, total	l	US gal	260	68.7
Hydraulic tank	l	US gal	165	43.6



DRIVETRAIN

Torque converter: Single-stage.

Transmission: Volvo BM power shift transmission of countershaft type with single-lever control. Directional clutch modulation provides faster and smoother shifting between forward and reverse.

Shifting system: Volvo BM Automatic Power Shift.

Axes: Fully floating half-shafts with planetary type hub reductions. One-piece cast-steel axle housing. Fixed front axle and oscillating rear axle.

Differential: 100% differential lock on front axle. Engagement and disengagement by means of switch on cab floor.

Hub reduction: VME manufacture with low-friction roller bearings on each planet wheel.

Tires: Alternative tires are available for different work operations.

Torque multiplication	2,27 : 1			
Transmission, make	Volvo BM			
Model	HT 220			
Running speeds				
1, forward/reverse	km/h	mph	6,5	4.0
2, forward/reverse	km/h	mph	12,1	7.5
3, forward/reverse	km/h	mph	24,0	14.9
4, forward	km/h	mph	35,1	21.8
Measurement with tires	26.5-25			
Front axle, make	VME			
Model	AWB 40			
Rear axle, make	VME			
Model	AWB 40			
Oscillation		±°	15	
Ground clearance at 15° oscillation	mm	in	610	24.0



BRAKE SYSTEM

The brake system meets the requirements of ISO 3450, SAE J1473 and EG 71/320

Service brakes: VME fully hydraulic-operated, outboard-mounted, enclosed, wet circulation oil-cooled disc brakes. Transmission disengagement during braking pre-selected via a switch on the instrument panel.

Secondary system: Dual-circuit system with rechargeable accumulators. One circuit or the parking brake fulfills the requirements.

Parking brake: Enclosed, wet disc brake built into the transmission. Spring-loaded application. Hydraulic release via a lever to the left of the operator.

Number of discs/wheel	1			
Area/brake pad	cm ²	in ²	1750	271
Brake area/wheel	cm ²	in ²	3500	542
Accumulators, volume, total	l	in ³	3	183
Parking brake, area, total	cm ²	in ²	2583	400
Accumulator, volume, total	l	in ³	0,5	30.5



STEERING SYSTEM

Load-sensing hydrostatic articulated steering with power amplification.

Pump: Variable-flow axial piston pump mounted on a power take-off on the transmission.

System supply: The steering system is fed from a separate steering pump.

Cylinders: Two double-acting cylinders with chromed piston rods.

Steering cylinders			2	
Bore	mm	in	100	3.9
Piston rod diameter	mm	in	50	2
Stroke	mm	in	418	16.5
Relief pressure	MPa	psi	21,0	3045
Max. flow	l/min	US gpm	116,6	30.8
at	MPa	psi	10	1450
and engine speed	rps	rpm	35,0	2100



CAB

Tested and approved according to standards: ROPS (ISO/CD 3471-1990, SAE J1040), FOPS (ISO 3449, SAE J231), also meets standard according to "Overhead guards for rider lift trucks" (ISO 6055) and "Operator Restraint System" (SAE J386).

Safety and comfort: The *Care Cab* has convenient boarding steps and a wide door opening. It is lined on the inside with sound-absorbent material and mounted on 4 rubber pads to damp sound and inhibit vibration. Large glazed areas, good all-round visibility. The windshield is curved and made of laminated green-tinted glass. All important operator information is presented clearly in front of the operator. Information panel for *Contronic* monitoring system.

Heater and defroster: Heating element with filtered fresh air and 4-speed fan which gives over pressure and defroster outlets for all windows.

Operator's seat: Spring-suspended, adjustable operator's seat with lap belt. The seat is hung on a bracket on the rear wall. The force from the seat belt is absorbed by the seat rails.

Emergency exits			3	
Sound level in cab (ISO 6396)				
max.	dB(A)		75	
Ventilation	m ³ /min	cfm	10	353
Heating capacity	kW	Btu/h	11	37500
Operator's seat			ISRI	6000/575



HYDRAULIC SYSTEM

Open center system with pilot-operated hydraulic valve.

Pump: A double pump (vane pump) mounted on a power take-off on the transmission. *Pump 1* works with all tilt and lift movements. *Pump 2* works with tilt out and lift up to 20 MPa (2900 psi). A pilot-controlled selector valve cuts-in flow to the system.

System supply: The pilot system is fed from a separate pilot pump, shared by the brake system.

Valve: Double-acting 3-spool valve. The control valve is actuated by a 3-spool pilot valve.

Lift function: The valve has four positions: Raise, neutral, lower and float. Disengageable inductive/magnetic automatic boom kick-out, adjustable for any position between maximum reach and full lift height.

Tilt function: The valve has three positions: Rollback, neutral and dump. Disengageable inductive/magnetic automatic bucket positioner, adjustable to any desired loading angle.

Cylinders: Double-acting.

Filters: Full-flow filtration through 10 micron nominal filter cartridge.

Loader unit: *Torque Parallel Linkage* – with very high breakout force throughout the working range. Good parallel lift-arm action with both level and fully angled-up bucket throughout entire lifting range. Lift cylinders mounted in line with lift-arms. Tilt cylinder mounted between lift-arms.

Main pumps				
Relief pressure, pump 1	MPa	psi	22,5	3362
Flow	l/min	US gpm	313,4	82.8
at	MPa	psi	10	1450
and engine speed	rps	rpm	35,0	2100
Relief pressure, pump 2	MPa	psi	20,0	2900
Flow	l/min	US gpm	91,5	24.2
at	MPa	psi	10	1450
and engine speed	rps	rpm	35,0	2100
Pilot pump				
Relief pressure	MPa	psi	3,0-4,5	435-652
Flow	l/min	US gpm	26,0	6.9
at	MPa	psi	10	1450
and engine speed	rps	rpm	35,0	2100
Lift cylinders				
Bore	mm	in	190	7.5
Piston rod diameter	mm	in	90	3.5
Stroke	mm	in	788	31.0
Tilt cylinder				
Bore	mm	in	260	10.2
Piston rod diameter	mm	in	120	4.7
Stroke	mm	in	480	18.9
Raise time *	s		6,6	
Dump time *	s		2,5	
Lower time (empty)	s		3,5	
Total cycle time	s		12,6	

* with load as per ISO 5998 and SAE J818.

DIMENSIONAL DATA VOLVO BM L180

Tires: 26.5 R 25*

Where applicable, specifications and dimensions are in accordance with ISO 7131, SAE J732, ISO 7546, SAE J742, ISO 5998, SAE J818.

B	mm	ft in	6960	22'10"
C	mm	ft in	3550	11'8"
D	mm	ft in	480	1'7"
F	mm	ft in	3560	11'8"
G	mm	ft in	2135	7'
J	mm	ft in	4100	13'5"
K	mm	ft in	4480	14'8"
O	°		57	
P	°		45	(Hook On)
P	°		49	(Pin On)
R	°		45	
R ₁ *	°		48	
S	°		71	
T	mm	ft in	110	0'4"
U	mm	ft in	520	1'9"
X	mm	ft in	2280	7'6"
Y	mm	ft in	2955	9'8"
Z	mm	ft in	4030	13'3"
a ₂	mm	ft in	6780	22'3"
a ₃	mm	ft in	3830	12'7"
a ₄		±°		37

* Carrying position SAE

The labels mentioned below show some examples of available buckets. For further information, see the attachment catalog.

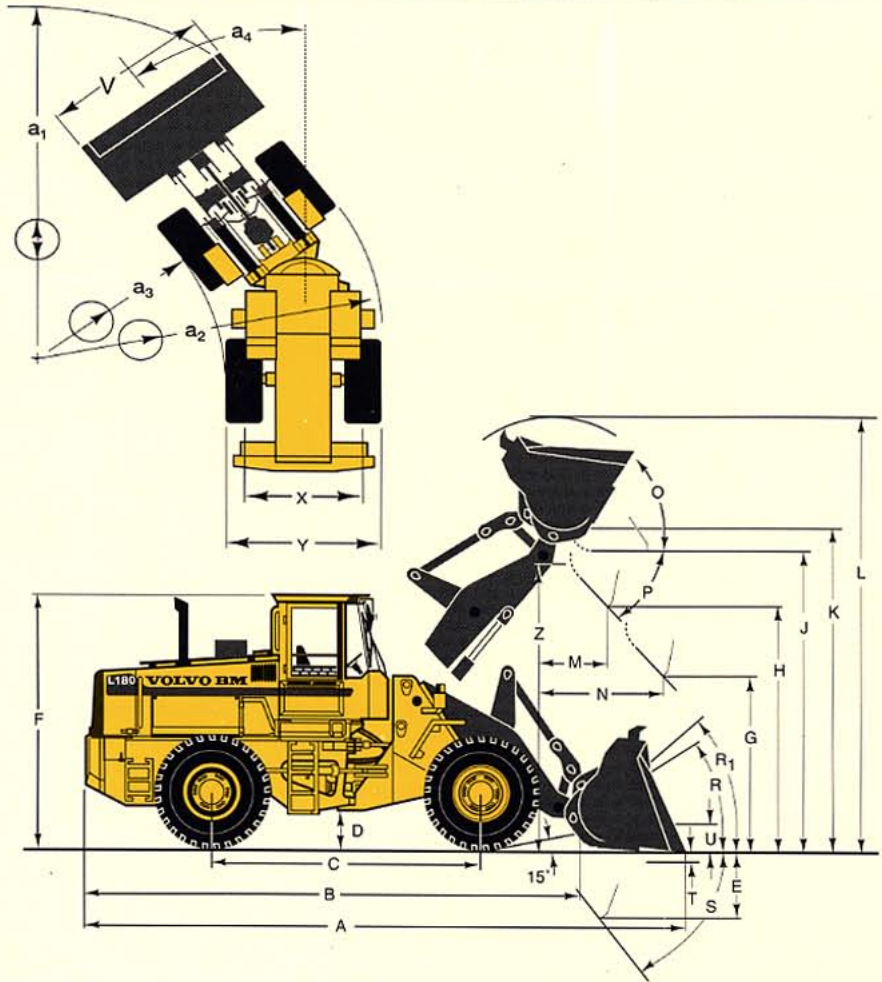

† Bucket Capacity includes Bolt-on Cutting Edge	Standard Buckets								Coal/Snow	
	Pin-On	Pin-On	Hook-On	Hook-On	Pin-On	Pin-On	Pin-On	Hook-On	Pin-On	
Volume, Heaped	m ³	4,8	4,6	4,8	4,6	4,6	4,4	4,2	4,4	7,5
	yd ³	6.3	6.0	6.3	6.0	6.0	5.8	5.5	5.8	9.8
Struck	m ³	3,8	3,6	3,8	3,6	3,6	3,5	3,4	3,5	6,1
	yd ³	4.97	4.71	4.97	4.71	4.71	4.58	4.45	4.58	7.98
Tipping load, straight	kg	18 500	19 100	17 800	18 400	18 700	18 800	19 300	18 100	18 400
	lb	40,800	42,100	39,300	40,600	41,200	41,500	42,600	39,900	40,600
35° turn	kg	16 300	16 900	15 600	16 200	16 400	16 500	17 100	15 800	16 200
	lb	35,900	37,300	34,400	35,700	36,200	36,400	37,700	34,800	35,700
at full turn	kg	16 000	16 600	15 300	15 900	16 100	16 200	16 800	15 600	15 900
	lb	35,300	36,600	33,700	35,100	35,500	35,700	37,100	34,400	35,100
Breakout force	kN	181	193	170	180	189	189	202	177	142
	lbf	40690	43390	38220	40460	42490	42490	45410	39790	31920
A	mm	8640	8540	8730	8620	8555	8580	8470	8660	9050
	ft in	28'4"	28'0"	28'8"	28'3"	28'2"	28'2"	27'10"	28'5"	29'7"
L	mm	6180	6180	6230	6230	6170	6130	6130	6180	6300
	ft in	20'3"	20'3"	20'5"	20'5"	20'3"	20'1"	20'1"	20'3"	20'8"
V	mm	3200	3200	3200	3200	3200	3200	3200	3200	3400
	ft in	10'6"	10'6"	10'6"	10'6"	10'6"	10'6"	10'6"	10'6"	11'2"
a, clearance circle	mm	14 960	14 900	15 010	14 950	14 920	14 920	14 870	14 970	15 350
	ft in	49'1"	48'10"	49'3"	49'0"	48'11"	48'11"	48'9"	49'1"	50'4"
E	mm	1420	1330	1500	1410	1350	1350	1270	1430	1770
	ft in	4'8"	4'4"	4'11"	4'7"	4'5"	4'5"	4'2"	4'8"	5'10"
H	mm	3070	3140	3020	3090	3120	3120	3190	3060	2830
	ft in	10'1"	10'3"	9'11"	10'2"	10'3"	10'3"	10'6"	10'0"	9'3"
M	mm	1330	1290	1390	1350	1280	1280	1240	1350	1660
	ft in	4'4"	4'3"	4'6"	4'5"	4'2"	4'2"	4'1"	4'5"	5'5"
N	mm	1960	1950	2000	1990	1930	1930	1920	1980	2070
	ft in	6'5"	6'4"	6'7"	6'6"	6'4"	6'4"	6'3"	6'6"	6'9"
Operating weight	kg	24 100	23 800	24 500	24 200	24 100	24 000	23 700	24 300	24 000
		53,100	52,500	54,000	53,400	53,100	52,900	52,300	53,600	52,900

Counterweight 1: 520 kg (1150 lb) is included in the specifications.

GENERAL PURPOSE GRAPPLE (HOOK-ON)

Order No.	91722			
Operating Weight	kg	lb	24 500	54,000
A	m ²	ft ²	1,8	19,38
B	mm	ft in	3770	12'4"
D	mm	ft in	3030	9'11"
E	mm	ft in	1760	5'9"
F	mm	ft in	1610	5'3"
G	mm	ft in	3120	10'3"
H	mm	ft in	5070	16'8"
I	mm	ft in	6770	22'3"
J	mm	ft in	2820	9'3"
K	mm	ft in	2900	9'6"
L	mm	ft in	2530	8'4"

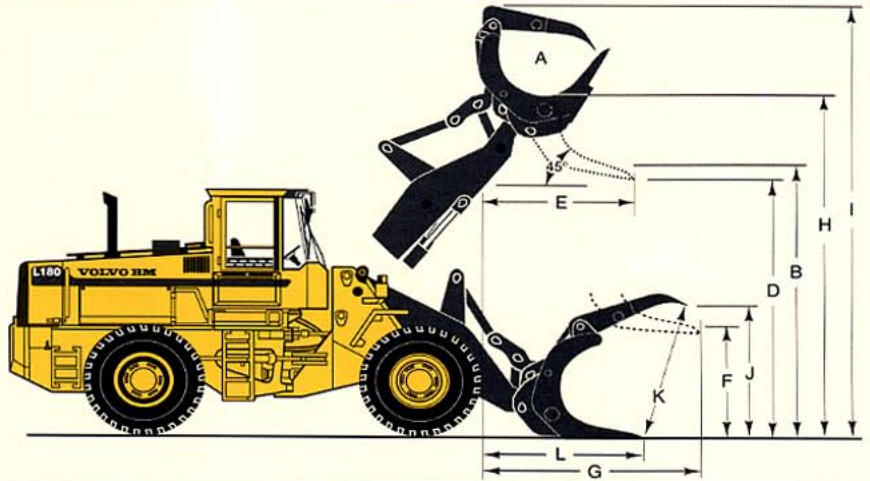

ATTACHMENTS

Buckets

Straight bucket without teeth	4,2-4,8 m ³	5.5-6.3 yd ³
Straight bucket with teeth	4,2-4,6 m ³	5.5-6.0 yd ³
Spade nose bucket without teeth	4,2 m ³	5.5 yd ³
Spade nose bucket with teeth	4,2 m ³	5.5 yd ³
Rock bucket	4,2 m ³	5.5 yd ³
Light materials bucket	7,5-14,0 m ³	9.8-18.3 yd ³
High-dump light materials bucket	7,0-13,0 m ³	9.15-17.0 yd ³

Timber grapples

Unloading grapple	3,3 m ³	35.5 ft ²
Sorting grapple	3,3 m ³	35.5 ft ²
General purpose grapple	1,8 m ³	19.4 ft ²

Tree length grapple	1,8 m ³	19.4 ft ²
Tropical timber grapple	1,4 m ³	15 ft ²
Heel/kickout		
Log Pusher		
Examples of other attachments		
Fork holder	2260 mm	7'5"
Fork tines	1500 mm	4'11"
Combination forks		
Fork attachments with fixed tines		
Materials handling arm		

ALTERATION OF DIMENSIONAL DATA

Tires		30/65 29 XRDNA L3	26.5 x 25 20PR (L-4)	26.5 x 25 20PR (L-5)	With Counterweight 2	Exclude Counterweight 1
Extra counterweight	kg lb				+750** +1650	-520* -1150
Width over wheels	mm in	+ 175 +7	+ 5 +0.2	- 10,2 - 0.4		
Ground clearance	mm in	± 0 ± 0	0 0	+20,3 +0.8		
Tipping load at full turn	kg lb	+ 395 +870	+308 +700	+508 +1120	+1420 +3130	-985 -1620
Operating weight	kg lb	+ 590 +1300	+479 +1056	+708 +1692	+750 +1650	-520 -1150

BUCKET SELECTION DIAGRAM

The volume of material handled is often greater than the bucket's ISO/SAE classification. Refer to the Material densities and bucket fill factor table prior to bucket selection.

***) Counterweight 1: 520 kg 1150 lb recommended for most applications.**

****) Counterweight 2: 750 kg 1650 lb can be used for stabilizing purposes in heavy-duty applications such as timber and pallet handling. Counterweight 2 replaces hydroinflation of rear tires.**

Combination of counterweights 1 + 2 should be used in extreme cases for stabilizing purposes, such as timber and pallet handling. Use only when working on a firm and flat surface.

*****) Counterweight 3: 260kg 573lb should only be used in timber applications.**

Bucket type m ³ yd ³	Material Density t/m ³ lb/yd ³							
	1.4 2360	1.5 2530	1.6 2700	1.7 2870	1.8 3030	1.9 3200	2.0 3370	2.1 3540
4.2 Pin-on 5.5					4.8		4.0	
					6.3		5.2	
4.4* Pin-on 5.8*			5.0		4.2			
			6.5		5.5			
4.6 Pin-on 6.0			5.3		4.4			
			6.9		5.8			
4.8* Pin-on 6.3*		5.5		4.5				
		7.2		5.9				

*) Including bolt-on cutting edge

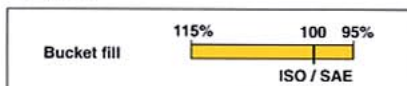

Material densities and bucket fill factor

Material	Earth	Clay	Sand	Gravel	Rock
Bucket fill %	100-115	110-120	100-110	100-110	75-100
Density t/m ³	1.4-1.6	1.4-1.6	1.6-1.9	1.7-1.9	1.5-1.9
Density lb/yd ³	2360-2700	2360-2700	2700-3200	2870-3200	2530-3200

STANDARD EQUIPMENT			
<p>Air cleaner, dry type dual element, exhaust aspirated precleaner Alternator, 24V, 60 AMP Battery disconnect, lockable Boom kickout, automatic Brakes, 4-wheel, hydraulic, sealed wet disc type, dual circuit Brake system, secondary Bucket leveler, automatic with position indicator Cab access steps & handrails (SAE J185) Cab: ROPS (SAE J1040C) (ISO 3471) FOPS (SAE J231) (ISO 3449) acoustical lining ash tray, cigarette lighter door, lockable (left side access) electrical system: 24V. pre-wired for optional accessories environmental control: heater/defroster/pressurizer 11kW (37,500 Btu/h) with four-speed blower fan, filtered air floor mat interior light interior rearview mirror</p>	<p>safety glass, tinted seat belt (SAE J386) seat, suspension, 6-way adjustable heated steering wheel, adjustable tilt, telescopic storage compartment sun visor windshield washer, front & rear windshield wiper, front, intermittent windshield wiper, rear Cold starting aids: engine fuel enrichment engine intake manifold pre-heater Contronic monitor display Differentials: front, hydraulically operated differential lock rear, conventional Drawbar with pin Engine coolant filter Engine shut down to idle at: high engine coolant temperature low engine oil pressure high transmission oil temperature Exhaust rain cap (elbow type) Fenders, front & rear Fuel water separator Hydraulic control lever safety latch Hydraulic oil cooler</p>	<p>Hydraulic pressure test ports, quick connect Instrument/gauges, illuminated: engine coolant temperature gauge fuel gauge hourmeter transmission temperature gauge sight gauges: coolant level hydraulic fluid level Isolation mounts: cab, engine, transmission Lifting lugs Lights: driving (2-front), halogen with high/low beam, parking lights, stop/tail combination (2-rear) turn signals with hazard warning switch work lights, halogen (2-front, 2-rear) Mirrors, rearview, (2) exterior, (1) interior Muffler, spark arresting Neutral start feature Side panels, engine hood Steering frame lock Tires: 26.5 R 25 Transmission: modulated, with single lever control, automatic power shift, and operator controlled declutch</p>	<p>Valve, main hydraulic, three (3) spool, pilot operated Vandalism lock, provision for: batteries, engine coolant, engine oil, fuel, hydraulic fluid, converter/transmission fluid Warning alarms: central warning audible axle/brake temperature engine coolant parking brake horn, electric reverse alarm (SAE J994) Warning & monitoring lights: air cleaner restriction alternator malfunction central warning lamp: brake system pressure engine coolant temperature engine oil pressure parking brake applied (transmission in forward or reverse) temperature F/R axle/brake cooling transmission fluid temperature transmission oil pressure differential lock engine intake manifold preheater high beam driving lights parking brake applied</p>
OPTIONAL EQUIPMENT			
<p>Air conditioner, 7 kW (24,000 Btu/h) Air precleaner, heavy duty cyclone, turbo II type oil bath type Attachment rib kit Beacon, amber rotating Boom suspension system Bucket teeth, bolt-on, (8) (not for use on light material buckets) Cold starting aid, engine preheater-coolant and oil (110V - 1500W) Comfort drive control (CDC) Counterweight 1 Counterweight 2</p>	<p>Cutting edge, 3 pc. reversible bolt-on (not for use on high tip buckets) Dual service brake pedal Engine fan, suction Engine, low emission version, factory installed External Brake Cooler Fenders, extended Guards: belly plates headlights, front muffler guard taillights, rear windshield worklights, rear Hand throttle control</p>	<p>Hydraulic attachment bracket with separate locking system Hydraulic control for 3rd function Hydraulic control for 4th function Instrument/gauges: speedometer/tachometer Light, attachment flood (halogen) Lockable tool box Radio mounting kit (includes 2 speakers, antenna & voltage reducers) Retractable seat belt Secondary steering Sliding window, door Slow moving vehicle emblem Spillguard, bolt-on</p>	<p>(not for use on light material buckets) Strainer for fueling Switch, forward/reverse shifting Tire options: 26.5 x 25 (L-2) 26.5 x 25 (L-3) 26.5 x 25 (L-4) 26.5 x 25 (L-5) 26.5 R 25 30/65 R 29 Working lights, front, extra Working lights, rear, extra</p>

Under our policy of continuous product improvement, we reserve the right to change specifications and design without prior notice. The illustrations do not necessarily show the standard version of the machine.

VME North America

One West Pack Square
BB&T Building
Asheville, NC 28801

Ref. No. 22 3 669 1958
DATE 1/94 REV.
Printed in U.S.A.