

# VOLVO BM 4300



## *Specification Volvo BM Loader 4300*

### PRODUCTIVE

A distinguishing characteristic of the Volvo BM 4300 is the well-balanced compatibility of all its units: engine; transmission; the excellent geometry of its loader unit, plus the new, wide attachment bracket enabling attachments to be changed quickly and easily. All these advantages add up to outstanding productivity.

### RELIABLE

Thorough laboratory testing and practical trials in demanding applications throughout Sweden and Europe have proven the 4300's high reliability and capacity.

### COMFORTABLE

The cab is the ultimate in design standards. It is sound suppressed and has a most efficient climatic control system. So operating the Volvo BM 4300 is both comfortable and safe. The driving seat, and the levers, controls and instrumentation, have been designed with great attention to detail. They have all been thoroughly tested under harsh working conditions, and all are located for ease of operating.







## ENGINE

Volvo BM TD42

Output, flywheel

67 kW at 36.5 r/s DIN 70020  
(91 hp at 2200 r/m)

79 kW at 36.5 r/s, SAE J 270  
(107 hp at 2200 r/m)

Max torque

324 Nm at 26.5 r/s, DIN 70020  
(33 kpm at 1600 r/m)

366 Nm at 26.5 r/s, SAE J 270  
(37.3 kpm at 1600 r/m)

Bore

105.5 mm (4.2 in)

Stroke

120 mm (4.7 in)

Number of cylinders 4

Displacement 4.2 lit (256 cu in)

The TD42 engine with direct injection has replaceable wet cylinder liners, light metal pistons and a crankshaft carried in five bearings. The engine air cleaning system cleans the intake air in three stages:

1. Cyclone precleaner with automatic dust ejection through the exhaust
2. Large replaceable paper filter with cab mounted indicator
3. Replaceable safety element



## ELECTRICAL SYSTEM

Voltage 24 V

Alternator 45 A (1250 W)

Battery 2 x 12 V, 96 Ah

Starter motor 3 kW (4 hp)

The alternator ensures efficient battery charging, even at low engine speed. The powerful starter motor gives easy cold-weather starting. Travelling and the powerful Halogen working lights, permit safe and efficient work in the dark. Fuse panel is well protected and easily accessible inside the cab.



## TORQUE CONVERTER

Volvo BM single-stage, single-phase torque converter.

Torque multiplication ratio 3.3:1



## TRANSMISSION

Volvo BM, countershaft type, full power shift transmission in four forward and four reverse speeds.

Maximum speeds forward and reverse with 17.5–25 tyres

1st 7 km/h 4.4 mph

2nd 11 km/h 6.8 mph

3rd 26 km/h 16.1 mph

4th 37 km/h 23 mph



## AXLES

Volvo BM design

Free floating axle shafts carry torque, not machine weight, and incorporate planetary hub reductions. The front axle is equipped with differential lock as standard. The long wheelbase, the big wheels, and rear axle oscillation contribute to the 4300's outstanding stability and go-anywhere mobility.



## BRAKES

Service

All wheels are equipped with air over hydraulic self-adjusting disc brakes. For maximum safety, the brake system is split into

two independent circuits — one for the front wheels and one for the rear wheels.

Parking, Mechanical on transmission shaft.



## TYRES

Choice of

17.5–25/12 — L2, L3



## STEERING

Centre-point frame articulation

Steering angle  $\pm 40^\circ$

Turning radius ( $a_2$ ) 5 m (16'5")  
(over tyres)

Gear-type design

68 lit (15 Imp gal)/at 10 MPa (1420 PSI)  
and 2200 r/m

Pump

Pump output

Relief pressure

10.5 MPa (1500 PSI)

The design of the steering system provides easy smooth steering without bumps and jolts being felt through the wheel. The system provides approved emergency steering.



## HYDRAULIC SYSTEM

Pump

Pump output

Gear-type design

180 lit (39.6 Imp gal)/min at 10 MPa  
(1420 PSI) and 2200 r/m

14 MPa (2000 PSI)

Relief pressure

Cylinders:

Lift — bore and stroke 110 x 950 mm (4.3 x 37.4 in)

Tilt — bore and stroke 100 x 745 mm (3.9 x 29.3 in)

Raise 5.1 sec

Lower 3.1 sec

Dump 2.0/3.5 sec

Control valve:

Three spool valve with built-in pressure relief valve

Functions

1. Tilt

2. Lift — float position with hold lock

3. Attachment or external hydraulics

The hydraulic system is equipped with a 3rd hydraulic control as standard and a 4th function can easily be added. The reliable lever system allows easy-touch operation. The hydraulic oil tank is extra-large for maximum cooling of the oil. The vented air in the tank passes through the engine-air cleaner.



## SERVICE REFILL CAPACITIES

Cooling system 23 lit (5.1 Imp gal)

Crankcase 12 lit (2.6 Imp gal)

Transmission and torque converter 24 lit (5.3 Imp gal)

Front axle differential and hubs 32.6 lit (7.2 Imp gal)

Rear axle differential and hubs 17.9 lit (3.9 Imp gal)

Hydraulic system 140 lit (30.8 Imp gal)

Hydraulic tank 105 lit (23 Imp gal)

Fuel tank 195 lit (43 Imp gal)



## CAB

The all-welded ROPS cab has two lockable doors and a roof hatch. The cab is approved in accordance with ROPS standards

(SEA J-394). The operator's station is ergonomically designed, with all controls and pedals located and designed for quick and easy operation. The operator's seat is fully adjustable. In its standard version, the cab is equipped with an efficient heating and ventilation system, with front and side window defrosters. The cab is mounted on the chassis via rubber pads, thereby minimizing the noise level inside the cab.



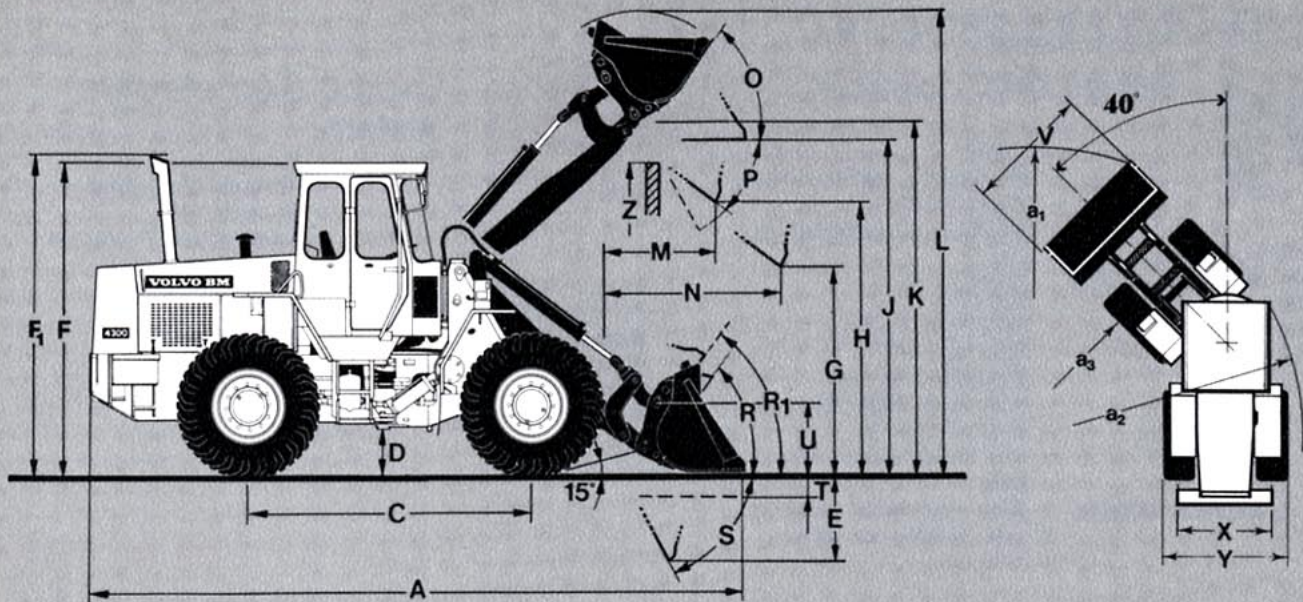

## DIMENSIONS

A = Listed below	K = 3720 mm (12'2")	S = 58°
C = 2700 mm (8'10")	L = Listed below	T = 90 mm (3.5")
D = 400 mm (15.7")	M = Listed below	U = 460 mm (18")
E = 750 mm (29.5")	N = Listed below	V = Listed below
F = 2970 mm (9'9")	O = 52°	X = 1860 mm (6'1")
G = 2000 mm (6'6")	P = 45°	Y = 2300 mm (7'7")
H = Listed below	R = 41°	Z = 3300 (10'10") bucket
J = 3565 mm (11'8")	R <sub>1</sub> = 50° Carry position	

$\alpha_1$ = Listed below
$\alpha_2$ = 5000 mm (16'5")
$\alpha_3$ = 2700 mm (8'10")
$\alpha_4$ = ±40°

## OPERATING SPECIFICATION

Attachment		Bucket pin on	Bucket hook on	Bucket pin on	Bucket hook on	Log grapple	Pallet fork
		1.3 m <sup>3</sup> (1.7 cu yd)	1.3 m <sup>3</sup> (1.7 cu yd)	1.6 m <sup>3</sup> (2.1 cu yd)	1.6 m <sup>3</sup> (2.1 cu yd)	0.9 m <sup>2</sup> (9.7 sq ft)	width 1200 (4') length 1200 (4')
Dump clearance at full lift 45° discharge (H)	mm (ft in)	2975 (9'9")	2920 (9'7")	2900 (9'6")	2835 (9'4")		
Reach at full lift and 45° discharge (M)	mm (ft in)	880 (2'11")	940 (3'1")	955 (3'2")	1020 (3'4")		
Reach at 45° discharge and 7 ft height (N)	mm (ft in)	1525 (5)	1560 (5'1")	1570 (5'2")	1610 (5'3")		
Overall length (A)	mm (ft in)	6285 (20'7")	6360 (20'10")	6390 (20'7")	6480 (21'3")		
Overall height with attachment (L)	mm (ft in)	4715 (15'5")	4765 (15'8")	4850 (15'11")	4900 (16'1")		
Turning radius (over bucket) ( $\alpha_1$ )	mm (ft in)	5400 (17'8")	5400 (17'8")	5480 (17'11")	5480 (17'11")		
Width (over bucket) (V)	mm (ft in)	2350 (7'9")	2350 (7'9")	2350 (7'9")	2350 (7'9")		
Breakout force	kg (lb)	8100 (17860)	7400 (16315)	7150 (15760)	6450 (14220)		
Static tipping load, straight	kg (lb)	5600 (12350)	5400 (11900)	5500 (12125)	5200 (11464)		
Static tipping load at 35° turn	kg (lb)	4900 (10800)	4700 (10360)	4800 (10580)	4500 (9920)		
Static tipping load at full (40°) turn	kg (lb)	4800 (10580)	4600 (10140)	4700 (10360)	4400 (9700)		
Operating load at full turn	kg (lb)	2400 (5290)	2300 (5070)	2350 (5180)	2200 (4850)	2200 (4850)	2800 (6175)
Operating weight	kg (lb)	8575 (18900)	8700 (19180)	8650 (19070)	8775 (19345)	8960 (19750)	8530 (18805)

Specifications are based on machine equipped with all standard equipment 17.5—25/12 L2 tyres and bucket as indicated. Wherever applicable, specifications are in accordance with SAE Standards J 732 c and J 742 b. Specifications and design are subject to change without further notice.

Optional tyre equipment	Change in basic data		Change in operating weight (kg/lb)	Change in static tipping load at full turn (kg/lb)	
	width over tires	Ground clearance			
17.5—25/12 — L2 Radial XR type A	±0	±0	+ 50 (110)	+ 125 (275)	



# STANDARD EQUIPMENT



## Safety and comfort

- ROPS safety cab
- Instrument panel with symbols
- Utility basket in cab
- Mounting for seat belt
- Cigarette-lighter
- Ashtray
- Horn
- Heating and ventilation system with defroster
- Sunvisor
- Pressure gauge for air brakes
- Comfort seat
- Fenders
- Lights:
  - Headlights, high/low beam
  - Parking lights
  - Working lights forward and rear
  - Brake lights
  - Tail lights
  - Side marker lights
  - Cab lighting
  - Instrument lighting
  - Turn signal indicators
  - Hazard flashers
- Windshield wipers, front and rear
- Rear-view mirrors, external
- Tyre inflation connection
- Tool kit



## Engine and electric system

- Battery disconnect switch
- Gauges and indicators:
  - Engine temperature
  - Engine oil pressure
  - Battery charging
  - Air filter service
  - Fuel
- Torque converter-oil temperature
- Transmission oil pressure
- Low brake pressure
- Parking brake
- Hour meter
- Working lights
- Inspection lamp outlet
- Compressed air outlet
- Muffler
- Alternator



## Power train

- Power shift transmission, counter shaft type
- Single lever control
- Differential lock on front axle
- Tyres 17.5—25/12
- Transmission cut-out valve



## Hydraulic system

- 3 hydraulic controls
- Bucket position indicator
- 2 alternative forward dumping speeds

# OPTIONAL EQUIPMENT

- Extra fuel filter (in addition to standard)
- Heavy-duty air cleaner
- Engine block heater: electric or propane
- Speedometer/odometer
- Alternative types or tyres
- 4th hydraulic function
- Double brake pedals
- Hydraulic outlet
- Extra working lights
- Air conditioner
- Underbody protection plates
- Towing hitch
- Inspection lamp
- Heated seat
- Lifting eyes for shipping
- Attachment bracket with quickchange coupling mechanical or hydraulic locking
- Protective screen for lights, front and rear
- Safety belt
- Single acting lifting function
- Rotating beacon with or without collapsible mounting bracket
- Automatic lubrication system
- Tyre inflation kit
- Bucket positioner and boom kick out
- Windscren washers

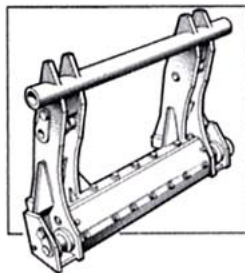

## "Quick-change" Coupling System

The Volvo BM 4300 may be delivered with quick-change coupling for hydraulic locking as optional equipment to fully utilize the wide range of attachments available.

*The manufacturers reserve the right to change specification or design without prior notice. Illustrations do not necessarily show the machine in its standard version.*

# VOLVO BM

VOLVO BM AB ESKILSTUNA SWEDEN

Ref.No. 21 1 669 1428  
ENGELSKA

Production group for basic printed matter Volvo BM  
Photo Studio Holland