



Michigan L270B



ENGINE OUTPUT
360 hp (268,5 kW)

DIRECT-INJECTED, TURBO-CHARGED, FUEL EFFICIENT CUMMINS DIESEL

OPERATING WEIGHT
91,070 lb (41,3 t)

BUCKETS 7.0 - 8.0 yd³
(5,35 - 6,12 m³)

DOUBLE-PLATE BOOM

POWERSHIFT, COUNTER-SHAFT TRANSMISSION WITH SINGLE LEVER ELECTRIC SHIFT CONTROL

LIMITED SLIP DIFFERENTIALS, FRONT AND REAR

SEALED, MULTI-DISC, LIQUID COOLED SERVICE BRAKES

SEAT MOUNTED, FINGERTIP HYDRAULIC CONTROLS

INTEGRAL, CLIMATE-CONTROLLED ROPS/FOPS CAB

MICHIGAN



ENGINE

Direct-injected, turbocharged, 6 cylinder, in-line, 4-cycle diesel.

Make Model	Cummins KT-19C	
Max. rating* at	2100 rpm	(35 rps)
SAE J1349 (ISO 1585)	400 hp	(298,3 kW)
Flywheel rating** at	2100 rpm	(35 rps)
SAE J1349 (ISO 1585)	360 hp	(268,5 kW)
DIN 70020/6271	360 hp	(268,5 kW)
Max. torque at	1500 rpm	(25 rps)
SAE J1349 (ISO 1585)	1350 lbf ft	(1830 Nm)
DIN 70020/6271	1350 lbf ft	(1830 Nm)
Number of cylinders	6	
Displacement, total	1150 in ³	(18,8 l)
Bore	6.25 in	(158,8 mm)
Stroke	6.25 in	(158,8 mm)

Air Cleaners

1. Cyclone precleaner with automatic dust ejector.
2. Paper filter with restriction indicator.
3. Replaceable safety filter.

***Max. rating** - Rating of engine equipped only with components essential for engine function, such as injection pump, oil pump, and water pump.

****Flywheel rating** - Net rating measured with fan, intake and exhaust system, cooling system, and alternator mounted.



ELECTRICAL

The electrical system is well protected by circuit breakers and pre-wired for optional equipment.

Voltage	24 V
Alternator	100 A
Batteries (12 volt)	4
Battery capacity, total	1250 CCA
Cranking capacity, ea.	625 CCA



SERVICE REFILL CAPACITIES

Crankcase	11.0 US gal	(41,6 l)
Fuel tank (total)	188.0 US gal	(711,6 l)
Fuel tank (usable)	180.0 US gal	(681 l)
Cooling system	26.0 US gal	(98,4 l)
Transmission (total)	24.0 US gal	(90,9 l)
Wheel hubs, each	2.5 US gal	(9,5 l)
Differentials, each	16.0 US gal	(60,5 l)
Midmount bearing	1.25 US gal	(4,7 l)
Hydraulic system (total)	120.0 US gal	(454,2 l)
Hydraulic tank	92.0 US gal	(348,0 l)



DRIVETRAIN

Torque converter: Clark, high efficiency single-stage, single-phase.

Transmission: Clark, countershaft-type powershift transmission with directional clutch modulation.

Axles: Clark, full floating axle shafts with planetary-type hub reductions. Single piece cast axle housings. Fixed front axle and oscillating rear axle.

Differentials: Clark, limited slip differentials in front and rear axles.

Hub reduction: Clark, planetary drive with low-friction roller bearings in each wheel hub.

Tires: Tubeless with nylon cord body. Optional tires available for specific applications.

Torque converter make, model	Clark, C 8602-119
Torque multiplication	3.050:1
Transmission make, model	Clark, 5421-180
Speeds, forward/reverse	
1	4.2 mph (6,8 km/h)
2	7.4 mph (11,9 km/h)
3	12.5 mph (20,1 km/h)
4	21.5 mph (34,6 km/h)
Measured with tires	29.5-29(28PR)L-4
Front axle make, model	Clark, D-75830
Rear axle make, model	Clark, D-75830
Rear axle oscillation, total	24 deg
.....	22 in (559 mm)



BRAKES

The brake system meets requirements according to SAE J1152,ISO 3450

Service Brakes: Full hydraulic system with outboard mounted, oil cooled, wet disc brakes at each wheel.

Left pedal applies brakes and shifts transmission into neutral. A separate dash-mounted switch allows the operator to deactivate this declutch feature.

Secondary: Dual circuit axle-by-axle system. Actuated by service brake pedals. Audible and visual low pressure alarm. Dead engine braking capability provided by two nitrogen-charged accumulators.

Parking brake: Dry disc type mounted on front axle input shaft. Spring applied, hydraulically released; actuated by dash-mounted switch.

Transmission interlock applies service brakes if shifted into forward or reverse to prevent moving machine when parking brake is applied.

Pump: Piston pump, pressure compensated.

Filtration: Full-flow, 10 micron filter.

Pressure setting	3000 psi	(20,7 MPa)
Service brake,		
disc dia.	17.8 in	(452,6 mm)
Parking brake,		
disc dia.	18 in	(457 mm)
thickness	0.5 in	(12,7 mm)

OPERATIONAL DATA & DIMENSIONS - MICHIGAN L 270B

Tires: 29.5-29 (28PR)L-4

Wherever applicable, specifications are in accordance with SAE Standards J732 and J742. Changes from the standard configuration may change machine dimensions and operating data. Operating weight is approximate and includes the bucket given in the table, ROPS cab, 7600 lb (3447 kg) counterweight and all standard equipment.

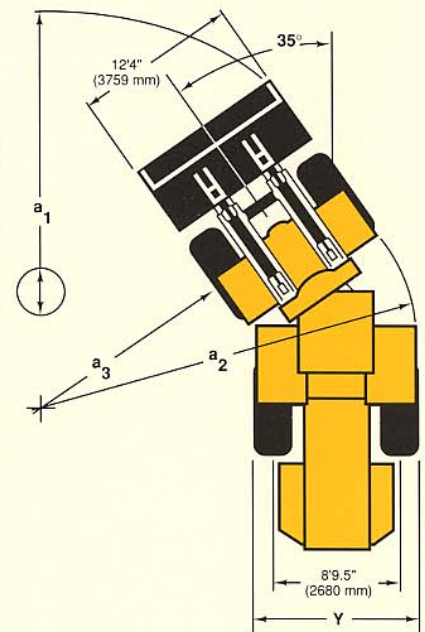
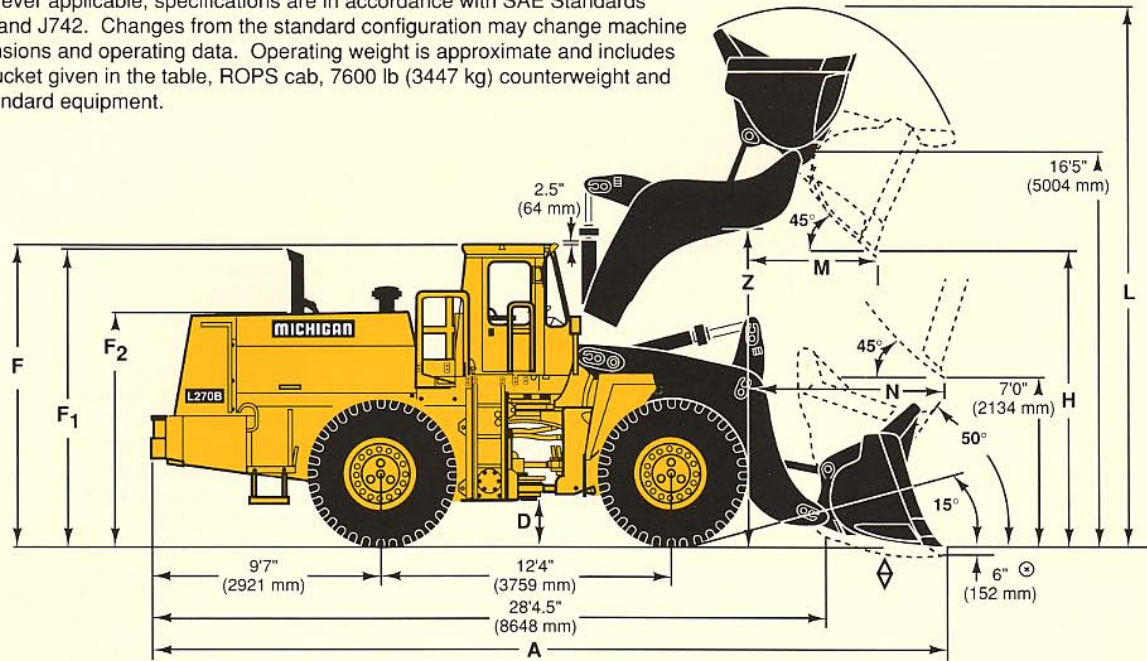

BUCKET TYPE	Straight Edge Rock		Spade-Nose Rock		Material Handling	
	Volume	Weight	Volume	Weight	Volume	Weight
Volume, heaped	yd ³	7.0	7.0	7.0	8.0	
	(m ³)	(5,35)	(5,35)	(5,35)	(6,12)	
struck	yd ³	5.9	5.9	5.9	6.9	
	(m ³)	(4,5)	(4,5)	(4,5)	(5,3)	
Bucket weight	lb	8380	8700	8700	8230	
	(Kg)	(3801)	(3946)	(3946)	(3733)	
Static tipping load, straight	lb	56,680	56,090	56,090	58,575	
	(Kg)	(25 710)	(25 442)	(25 442)	(26 570)	
full turn	lb	50,010	49,480	49,480	51,755	
	(Kg)	(22 685)	(22 444)	(22 444)	(23 476)	
Breakout force	lbf	80,000	69,000	69,000	77,714	
	(kN)	(355,8)	(306,9)	(306,9)	(345,7)	
A Δ	ft in	33'7"	34'4"	34'4"	33'10"	
	(mm)	(10 236)	(10 465)	(10 465)	(10 312)	
H ⊙	ft in	12'3"	11'9"	11'9"	12'1"	
	(mm)	(3734)	(3581)	(3581)	(3673)	
L	ft in	22'10"	22'10"	22'10"	22'2"	
	(mm)	(6960)	(6960)	(6960)	(6756)	
M ⊕	ft in	5'7"	6'2"	6'2"	5'6"	
	(mm)	(1702)	(1880)	(1880)	(1689)	
N ⊙	ft in	8'4"	8'10"	8'10"	8'4"	
	(mm)	(2540)	(2692)	(2692)	(2540)	
a ₁ Clearance circle (over bucket in carry position)	ft in	56'2"	56'7"	56'7"	56'4"	
	(mm)	(17 120)	(17 247)	(17 247)	(17 170)	
Operating weight	lb	91,070	91,540	91,540	90,640	
	(Kg)	(41 309)	(41 523)	(41 523)	(41 114)	

- Δ Add 9.7 in (246 mm) for bucket teeth
- ⊙ Deduct 7.0 in (178 mm) for bucket teeth
- ⊕ Add 8.0 in (203 mm) for bucket teeth
- ⊙ Add 2.4 in (61 mm) for bucket teeth
- ◇ Maximum grading angle 50°

OPERATIONAL DATA - MICHIGAN L270B

Tires: 29.5-29 (28PR) L-4

SUPPLEMENTAL OPERATING DATA		Change in operating weight	Change in static tipping load straight	Change in static tipping load at full turn
Air conditioner (removal)	lb (kg)	-100 (-45,4)	-170 (-77)	-150 (-68)
Bucket Points and Adapters				
37R Points	lb (kg)	+134 (+61)	-170 (-77)	-148 (-67)
37ARLB Points	lb (kg)	+268 (+122)	-340 (-154)	-296 (-134)
37TFP Points	lb (kg)	+143 (+65)	-182 (-83)	-158 (-61)
Single Leg Shank	lb (kg)	+297 (+135)	-377 (-171)	-328 (-149)
1 1/2 Leg Shank	lb (kg)	+342 (+155)	-434 (-197)	-378 (-171)
Counterweight	lb (kg)	+2400 (+1089)	+4640 (+2105)	+4060 (+1842)
ROPS cab (removal)	lb (kg)	-1800 (-817)	-1280 (-581)	-1120 (-508)
ROPS, canopy, open (in lieu of ROPS cab)				
Fenders, front	lb (kg)	+260 (+118)	+60 (+27)	+50 (+23)
Secondary steering	lb (kg)	+100 (+45,4)	+130 (+59)	+110 (+50)
3rd hydraulic control	lb (kg)	+115 (+52)	0 (0)	0 (0)
Optional tires:				
29.5-29(28PR)L-3	lb (kg)	-1560 (-708)	-980 (-445)	-860 (-390)
29.5-29(28PR)L-4(STD)	lb (kg)	0 (0)	0 (0)	0 (0)
29.5-29(28PR)L-5	lb (kg)	+1486 (+671)	+933 (+424)	+819 (+372)
29.5-29(28PR)L-5S	lb (kg)	+1968 (+893)	+1239 (+563)	+1087 (+494)
29.5-29(34PR)L-3	lb (kg)	-1100 (-499)	-690 (-313)	-600 (-272)
29.5R29XRDNAT*	lb (kg)	-1784 (-810)	-1119 (-508)	-982 (-446)
29.5R29XRD1AT*	lb (kg)	-895 (-407)	-558 (-253)	-490 (-222)
29.5R29XRAT*	lb (kg)	-2244 (-1018)	-1411 (-641)	-1238 (-563)
29.5R29RL-2F**L-2	lb (kg)	-2260 (-1025)	-1420 (-644)	-1240 (-562)
29.5R29RL-3**L-3	lb (kg)	-316 (-143)	-198 (-90)	-174 (-79)
+35/65-33(24PR)L-4	lb (kg)	+428 (+194)	+269 (+122)	+236 (+107)
+35/65-33(24PR)L-5	lb (kg)	+1852 (+841)	+1161 (+527)	+1019 (+462)
+35/65-33(24PR)L-5S	lb (kg)	+3264 (+1481)	+2045 (+929)	+1795 (+815)
+35/65-33(30PR)L-4	lb (kg)	+1780 (+807)	+1120 (+508)	+980 (+445)
+35/65-33(30PR)L-5	lb (kg)	+3300 (+1497)	+2070 (+939)	+1810 (+821)
+35/65R33XRDNAT*	lb (kg)	-568 (-258)	-361 (-164)	-317 (-144)
+35/65R33XRD1AT*	lb (kg)	+1900 (+262)	+1198 (+344)	+1051 (+477)
+35/65R33XRD2AT*	lb (kg)	+1648 (+748)	+1032 (+459)	+906 (+412)
+35/65R33RL-5E*L-5	lb (kg)	+2124 (+964)	+1333 (+605)	+1170 (+531)

+NOTE: Tire chains cannot be used with 35/65-33 tires.

DIMENSIONS AFFECTED BY TIRE SIZE

MACHINE DIMENSIONS	29.5-29 (L-2)	29.5-29 (L-3)	29.5-29 (L-4)	29.5R29 (L-5)	35/65-33 (L-4)	35/65-33 (L-5)
D ft in (mm)	1'8.5" (521)	1'9" (533)	1'10" (559)	1'11" (584)	1'11" (584)	1'11" (584)
F ft in (mm)	12'8.5" (3874)	12'9" (3886)	12'10" (3912)	12'11" (3937)	12'11" (3937)	12'11" (3937)
F ₁ ft in (mm)	12'5.5" (3797)	12'6" (3810)	12'7" (3835)	12'8" (3861)	12'8" (3861)	12'8" (3861)
F ₂ ft in (mm)	9'9.5" (2985)	9'10" (2997)	9'11" (3023)	10'0" (3048)	10'0" (3048)	10'0" (3048)
H ⊙ ft in (mm)	12'1.5" (3696)	12'2" (3708)	12'3" (3734)	12'4" (3759)	12'4" (3759)	12'4" (3759)
K ft in (mm)	16'3.5" (4966)	16'4" (4978)	16'5" (5004)	16'6" (5029)	16'6" (5029)	16'6" (5029)
L ft in (mm)	22'8.5" (6922)	22'9" (6934)	22'10" (6960)	22'11" (6985)	22'11" (6985)	22'11" (6985)
M ⊙ ft in (mm)	5'8.5" (1740)	5'8" (1727)	5'7" (1702)	5'6" (1676)	5'6" (1676)	5'6" (1676)
N ⊙ ft in (mm)	8'5.5" (2578)	8'5" (2565)	8'4" (2540)	8'3" (2515)	8'3" (2515)	8'3" (2515)
T ⊙ ft in (mm)	7.5" (191)	7" (178)	6" (152)	5" (127)	5" (127)	5" (127)
Y ft in (mm)	11'6" (3505)	11'6" (3505)	11'6" (3505)	11'6" (3505)	11'9" (3581)	11'9" (3581)
Z ft in (mm)	13'1.5" (4001)	13'2" (4013)	13'3" (4039)	13'4" (4064)	13'4" (4064)	13'4" (4064)
a ₂ ft in (mm)	25'5" (7747)	25'5" (7747)	25'5" (7747)	25'5" (7747)	25'8" (7823)	25'8" (7823)
a ₃ ft in (mm)	13'11" (4242)	13'11" (4242)	13'11" (4242)	13'11" (4242)	13'8" (4166)	13'8" (4166)



STEERING

Articulated frame: Full hydraulic steering system with speed sensor hydraulics provides adequate volume of oil to the steer valve for positive steering control at all engine speeds.

Pump: Fixed displacement gear-type mounted on torque converter, augmented by a variable displacement piston pump mounted on the torque converter.

Supply system: The system is served by the steer pump and the piston pump which is speed and pressure sensitive and feeds either the main hydraulic or the steering system.

Cylinders: Two double-acting cushioned cylinders with chrome plated piston rods.

Steering cylinders, no.	2	
Bore	5.0 in	(127 mm)
Stroke	19.56 in	(497 mm)
Relief pressure	2800 psi	(19,3 MPa)
Primary pump		
output	82 US gal/min	(311 l/min)
at pressure	1000 psi	(6,9 MPa)
and engine speed	2100 rpm	(35 rps)
Transfer pump		
output (flow to		
main system)	26 US gal/min	(98,4 l/min)
at pressure	1000 psi	(6,9 MPa)
and engine speed	2100 rpm	(35 rps)
Articulation:	35 deg	



CAB

Cab: Integral ROPS (SAE J1040, ISO 3471)/FOPS (SAE J231, ISO3449) with two lockable doors. Sound insulating lining. Sliding self-locking windows. Tinted safety glass in all windows.

Heater/Defroster/Air Conditioner: Provides filtered (10 microns) fresh air and has a three-speed fan and a defroster for the front and side windows.

Heater capacity	45,000 Btu/h	(13,2 kW)
Air conditioner	21,500 Btu/h	(6,3 kW)
Sound level in closed cab	85 dB(A)	

Operator's seat: Fully adjustable air suspension seat with seat belt (SAE J386).



HYDRAULICS

Closed and pressurized load-sensing system with a sturdy plate-steel tank. Hydraulic oil is fully filtered and cooled. An access hole is provided in the tank for easy cleaning. An in-tank magnet provides extra protection.

Pump: Fixed displacement gear type mounted on torque converter, augmented by variable displacement piston pump mounted on torque converter.

Supply system: The system is served by the large main pump and the piston pump which is pressure and speed sensitive and feeds either the main hydraulic or the steering system.

Valve: Split-spool valve with built-in pressure relief valve. Actuated by a pilot valve, it is mounted on front frame for easy access.

Lift function: The valve has four positions: raise, hold, lower and float. An automatic kickout detent is adjustable for any position between maximum reach and full lift height.

Tilt function: The valve has three positions: rollback, hold and dump. Automatic bucket positioner is adjustable to any desired loading angle.

Cylinders: Double-acting.

Filters: Full-flow 10 micron return filter (with two elements), located in hydraulic oil tank.

Relief pressure	2750 psi	(19,0 MPa)
Pump output	175 US gal/min	(662 l/min)
at pressure	1000 psi	(6,9 MPa)
and engine speed	2100 rpm	(35 rps)
Lift cylinders, no.	2	
Bore	9.0 in	(228,6 mm)
Stroke	44.9 in	(1141 mm)
Tilt cylinders, no.	2	
Bore	7.5 in	(190,5 mm)
Stroke	30.9 in	(785 mm)
Raising time (loaded)	8.6 s	
Dumping time (loaded)	3.0 s	
Lowering time (empty)	5.0 s	
Total cycle time	16.6 s	



BUCKET

A - Straight edge rock	7.0 yd ³	(5,4 m ³)
A - Spade-nose rock	7.0 yd ³	(5,4 m ³)
B - Material Handling	8.0 yd ³	(6,1 m ³)

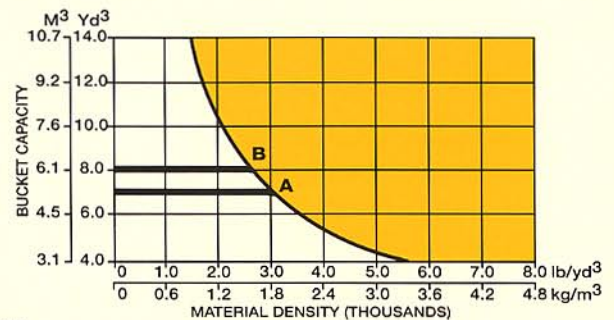

Note:

Correct Bucket Selection is determined by consideration of the work application, material density and type of material. Refer to Operational Data for bucket choices.

Contact your VME Distributor for assistance.

STANDARD EQUIPMENT

AIR CLEANER, DRY TYPE,
DUAL ELEMENT WITH EXHAUST
ASPIRATED PRECLEANER
ALTERNATOR, 24 V, 100 A
BATTERY DISCONNECT, LOCK-
ABLE
BOOM AND BUCKET CONTROL
LEVERS, FINGERTIP
BOOM AND BUCKET LINKAGE,
SEALED PINS
BOOM KICKOUT, AUTOMATIC,
ADJUSTABLE
BRAKES, 4 WHEEL HYDRAULIC
WET DISC, LIQUID COOLED
BRAKE SYSTEM, SECONDARY
BUCKET LEVELER, AUTOMATIC
CAB ACCESS STEPS & HAND-
RAILS (SAE J185)
CAB, ROPS (SAE J1040)
(ISO 3471)
Acoustical Lining
Doors (2); lockable with self-
locking sliding glass windows
Door Hold-Open Struts (2)
Electrical System: 24V,
circuit breaker protected,
pre-wired for optional
accessories
Environmental Control:
Air Conditioner, 21,500
Btu/h (6,3 kW)
Heater/Defroster/Pressurizer,
with three-speed blower fan,
45,000 Btu/h (13,2 kW)

Floor Mat
Interior Lights, Red and White
Interior Rearview Mirror
Safety Glass, Tinted
Seat, Air Suspension, 6-Way
Adjustable
Seat Belt (SAE J386)
Steering Wheel Spinner Knob
Sun Visor
Windshield Wiper & Washer,
Front and Rear
COLD START AID, ETHER INJEC-
TION
DIFFERENTIALS, LIMITED SLIP,
FRONT & REAR
DRAWBAR WITH PIN
DRIVE SHAFT GUARD, CON-
VERTER TO TRANSMISSION
GRILLE, REAR SWING-OUT
HYDRAULIC FLUID TO AIR COOLER
HYDRAULIC PRESSURE TEST
PORTS, QUICK CONNECT
INSTRUMENTS/GAUGES:
Air Cleaner Restriction Indicator
Engine Coolant Temperature Gauge
Engine Oil Pressure Gauge
Fuel Gauges, tank and dash
mounted
Hourmeter
Sight Gauges:
Engine Coolant Level
Hydraulic Fluid Level
Transmission Fluid Level
Transmission/Torque Converter
Fluid Temperature Gauge

Voltmeter
Isolation Mounts: Cockpit, Engine,
Radiator, Transmission
LIFTING LUGS
LIGHTS:
Work (70W) Halogen, 4 front,
4 rear
Stop and Tail Combination, 2 rear
LUBRICATION, MANIFOLD TYPE
GROUND LEVEL
MIRRORS, REARVIEW (2), EXTERIOR
NEUTRAL START FEATURE
REMOTE DRAIN FOR ENGINE OIL
SIDE PANELS, ENGINE HOOD, LOCKABLE
STEERING FRAME LOCK
TIRES: 29.5-29(28PR)-L-4 (GENERAL)
TRANSMISSION:
Powershift, with directional clutch modulation,
Shift Control, single lever electric, Declutch
pedal with Dash Mounted On/Off Switch
VANDALISM LOCK, PROVISION FOR:
Batteries, Engine Coolant, Fuel,
Hydraulic Fluid, Transmission/
Torque Converter Fluid
WARNING ALARMS:
Horn, electric
Reverse Alarm (SAE J994)
WARNING & MONITORING LIGHTS:
Air Conditioner Malfunction
Brake Pump/Differential Pressure
Brake System, front
Brake System, rear
Parking Brake Applied
Transmission/Brake Filter Restriction

OPTIONAL EQUIPMENT

Accessory Power Converter 12V/6A
Air Conditioner (removal)
Beacon Rotating Amber
Bucket (see Operational Data)
Points & Adaptors
Cutting Edge Wear Caps
Cab, ROPS (removal)
Canopy, Open ROPS
Counterweight 2400 lb (1090 kg)
Engine Oil Fill & Evacuation
(Wiggins)
Engine Preheater, coolant & oil
(120 & 240V)
Engine Shutdown to Idle Kit:
High Coolant Temperature
Low Engine Oil Pressure
Engine Warning System
Low Oil Pressure
Low Coolant Level
High Coolant Temperature
European Accessory
Fan, Reversible
Fenders & Mud Flaps, front

Fire Extinguisher
Fuel Fast Fill Coupler (Wiggins)
Guards:
Crankcase
Rear Light
Transmission
Hydraulic Control, 3 Spool Valve,
Piping & Controls
Hydraulic Fluid Fill & Evacuation
(Wiggins)
Instrument Cover Kit (ROPS
Canopy)
Logger Package
Lubrication System, Automatic
(Trabon)
Single Point Manual (Trabon)
Radiator Sand Grid
Secondary Steering (Electric)
Tiefbau Kit (for German regulations)
Warning & Monitoring Lights:
Low Engine Oil Pressure
Low Coolant Level

High Coolant Temperature
Low Steer Pressure (with
secondary steering only)
Tires:
29.5-29(28PR)-L-3
29.5-29(28PR)-L-4
29.5-29(28PR)-L-5
29.5-29(28PR)-L-5S
29.5-29(34PR)-L-3
29.5R29XRDNAT*
29.5R29XRD1AT*
29.5R29XRAT*
29.5R29RL-2F**L-2
29.5R29RL3*L-3
29.5R29RL-3**L-3
35/65-33(24PR)-L-4
35/65-33(24PR)-L-5
35/65-33(24PR)-L-5S
35/65-33(30PR)-L-4
35/65-33(30PR)-L-5
35/65R33XRDNAT*
35/65R33XRD1AT*
35/65R33XRD2AT*
35/65R33RL-5E*L-5*

Under our policy of continuous product improvement, we reserve the right to change specifications and design without prior notice. The illustrations do not necessarily show the standard version of the machine.

VME Americas Inc.

23001 Euclid Avenue
P.O. Box 178017
Cleveland, Ohio 44117-8017

FORM NO. L-499
DATE 4/91
PRINTED IN U.S.A.