

BM-VOLVO

LOADER LM 620

The LM 620 — a fast all-round loader with capacity for handling a wide variety of tasks. Especially suitable for haulage firms, local authorities, industry, builders and contractors as well as for forestry companies and farms.



High lift, long outreach, easy handling and a tight turning circle make the LM 620 a truly versatile loader. The comfortable, crash-proof driver's cab and hydraulically operated gearbox without clutch pedal ensure a high degree of convenience and safety, improved performance and less strain on the driver.

Fast!

The BM-VOLVO LM 620 – a fast loader with easy gear shifts and hydraulic transmission which provides for considerable savings in time and short work cycles. The properties of the hydraulic transmission give the LM 620 high penetration power for effective and rapid bucket filling. The well-dimensioned wheel base and large

wheels ensure good stability even on broken ground, especially in fork-lift operations. Its adaptability makes the LM 620 an excellent machine for snow clearance, handling goods by crane in stockyards, as tractor for implements, etc.





Versatile!

The LM 620 is included in the BM-VOLVO loader range which offers a standardized implement attachment with speed-coupling. Hydraulic control from the driver's seat is available as an optional extra. The speed-coupling gives the machine great versatility, enabling full utilization of the wide range of implements – more than 70 different units. The parallel side-arm linkage of the implement attachment ensures that the horizontal alignment

of the implement remains unchanged throughout the lifting movement.

This is a considerable advantage, for instance, when handling palletted goods. The wheels of the LM 620 in conjunction with the differential lock enable the loader to achieve great tractive power, excellent performance over difficult ground and high load-carrying capacity in all types of operation.

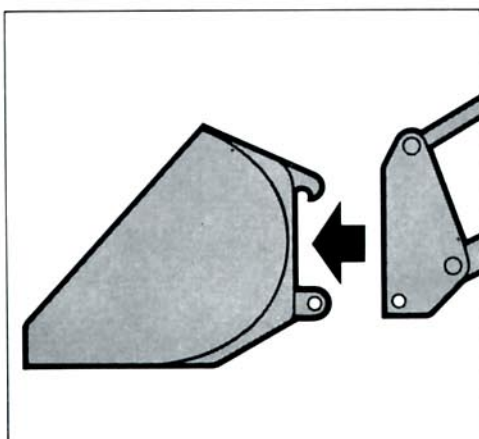

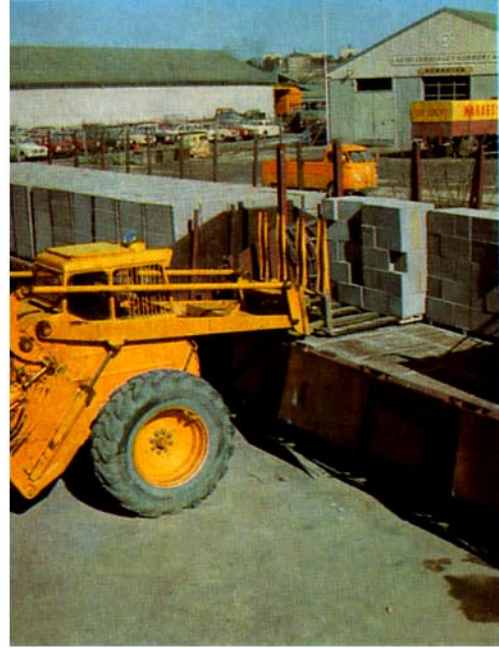

High lift – long outreach!

Its long outreach in front of the wheels enables the LM 620 to load and unload from truck platforms and railway wagons from one side. This also reduces the risk of damage to the tyres during loading. The high lift of the

loader in combination with the driver's clear view of the implement provides for good capacity and safety in stacking goods, for instance.

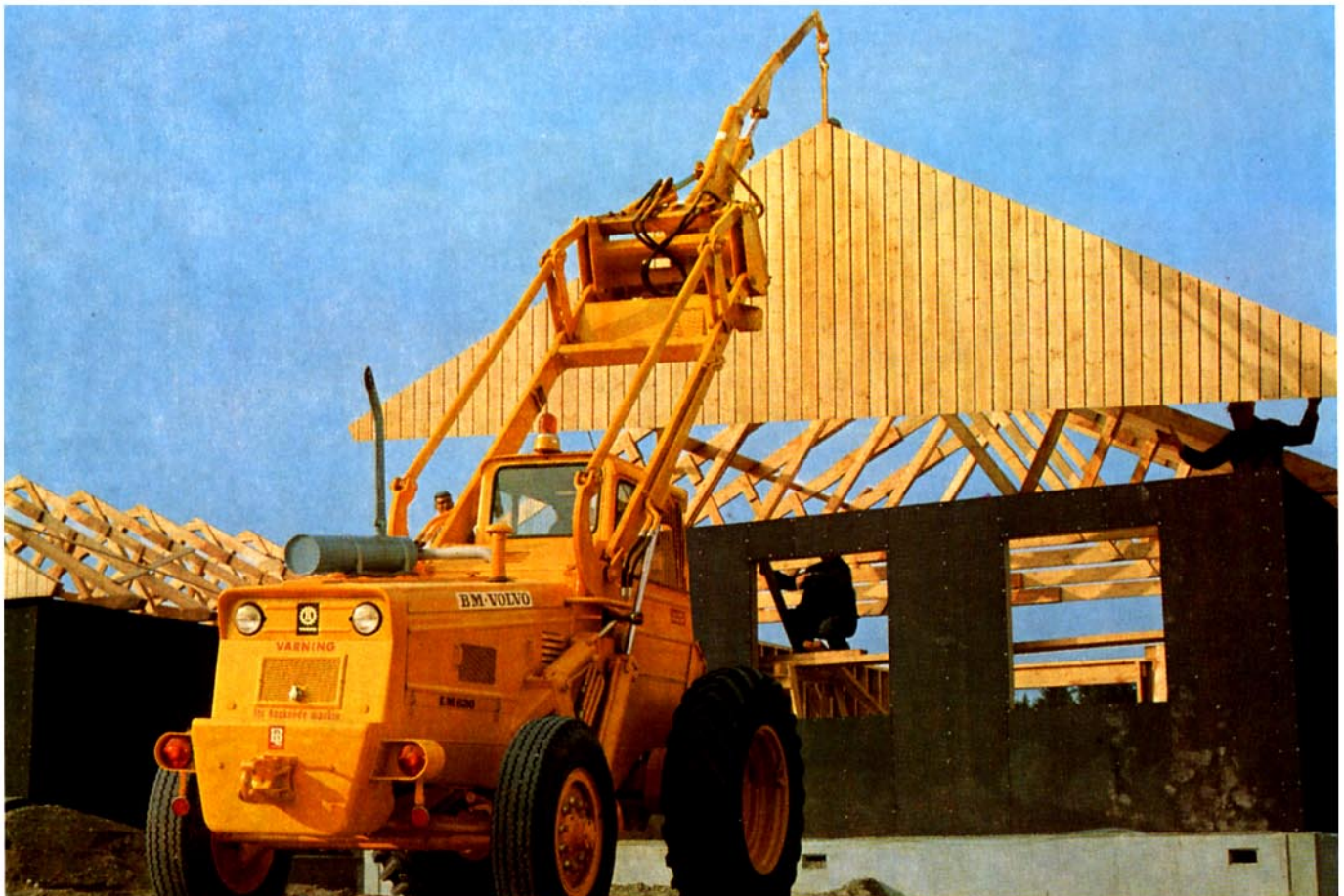



Good field of view – comfort – safety!

The safety cab of the LM 620 with opening windows, roof hatch, heating and ventilation offers good all-round visibility and the greatest possible comfort. Easy-to-reach controls, gear-shifts without clutch pedal, con-

centrated instrument display and adjustable, upholstered driver's seat contribute to a high degree of safety in the comfortable cab.

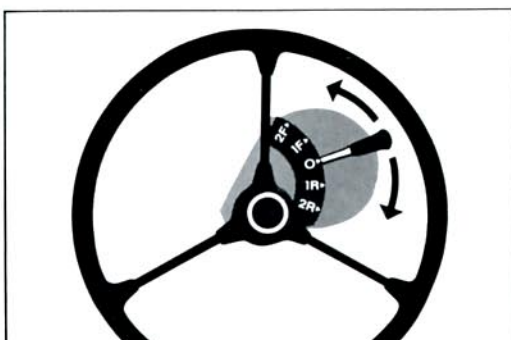



Easy to handle – nimble where space is confined!

The LM 620 is fitted as standard with hydraulic power steering which makes driving easy and convenient for the operator. This in combination with its tight turning circle makes the loader extremely fast and nimble where

space is restricted. Ground pressure is an important consideration in the case of ground with poor bearing capacity. The large wheels of the LM 620 ensure a low ground pressure – good floatation.

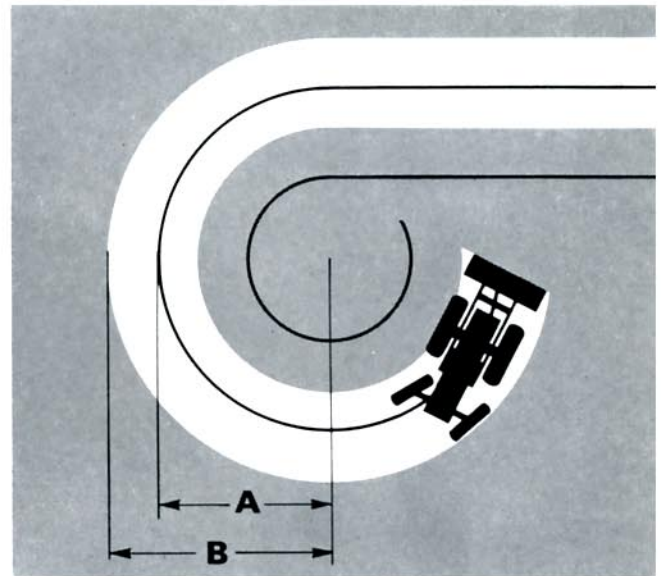

Tight turning circle!

The capacity and flexibility of a loader is determined to a great extent by the turning circle. The LM 620 has a short turning circle radius – only 16 ft – which the steering brake can reduce to 10 ft 6 in.

A turning radius with steering brake 10 ft 6 in.

B turning circle without steering brake 16 ft.



Reliable engine with low operating costs!

The LM 620 is powered by an endurance-tested, 3-cylinder, direct-injection diesel engine. The high torque the engine delivers over a wide speed range in conjunction with the torque converter provides the loader with ample

tractive power for every job. Relative to its capacity the engine is extremely economical on fuel. It is easily accessible for daily service.

SPECIFICATION

General particulars

Total weight with bucket	lb 13,900
Wheel base	in 90 1/2
Track, front	in 68 1/2
Track, rear	in 67
Turning circle, radius	ft 16
Tyres, front	16.9—30/10
Tyres, rear	9.00—20/10

Engine

3-cyl., 4-stroke, direct-injection diesel engine type	BM 1113 A LH
Capacity	230
SAE/DIN, hp	69/63
Max. torque, SAE/DIN, kgf	25.0/23.7

Transmission

Torque converter and hydraulic power-shift.
Two speed ranges with a total of 4 speeds forward and reverse.
Differential lock, hand-operated.

Speed ranges: forward-reverse, mph

I	0—4.0
II	0—6.5
III	0—11.3
IV	0—18.4

Loading unit

Bucket volumes	cu.yd. 0.9—3.9
Outreach at a height of approx. 7'	ft. in 4'7"
Max. lift under tipped bucket	ft. in 9'6"

Hydraulics

Capacity of hydr. pump	Imp.gal/min 30.8
Working pressure of hydr. system	lb/sq.in 1,280

Standard equipment

Comfortable and safe driver's cab, rubber mat in cab, rearview mirror in cab, hour-recorder and fuel gauge, 460-W alternator, three hydr. functions incg. fluid line and controls, direction indicators, el. windscreen wiper with blades for top and bottom window sections, fresh-air intake, heater, hydr. power steering, steering brakes, differential lock, twin headlights front and rear, tail lights, parking lights, position lights, electric plug for trailers, electric horn and sun visor, guard grill over lower window of door.

Optional equipment

4th hydr. function incg. fluid line, control lever for 4th hydr. function, separate control lever for 3rd and 4th functions combined, fluid line complete for trailer tipper, engine preheater, 750-W plug-in heater, industrial towing hook, revolving light. Extra working lights. GN spring unit under seat. Implement attachment with hydr. locking.

The manufacturer reserves the right to introduce changes without previous notice.

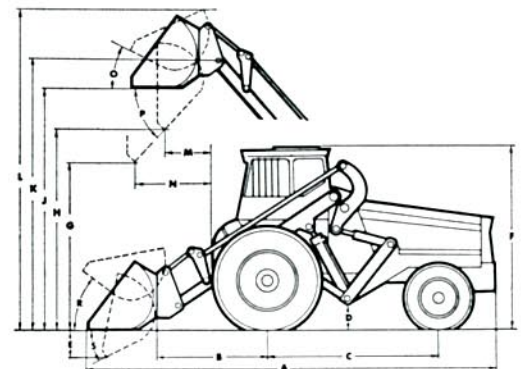

Dimensions

A	17' 10"	K	12' 7"
B	4' 10"	L	14' 10"
C	7' 6"	M	2' 1"
D	1' 1"	N	4' 7"
E	2'	O	43°
F	8' 3"	P	43°
G	6' 7"	R	42°
H	9' 6"	S	41°
J	11' 6"			



BM-VOLVO LM 620 ***all-round loader***

Fast!

The LM 620 — a fast loader with easy gear shifting and hydraulic transmission.

Versatile!

The LM 620 implement attachment with speed-coupling gives the machine great versatility.

High lift!

The high lift in combination with the driver's clear view of the implement guarantees good capacity and safety.

Long outreach!

The long outreach of the LM 620 facilitates loading and unloading from truck platforms and railway wagons from one side.

Comfort!

Gear-shifts without clutch pedal, concentrated instrument display and adjustable driver's seat give the cab a high degree of comfort.

Good safety!

The crash-proof steel cab of the LM 620 with good all-round visibility, opening windows and roof hatch ensures good safety.

Large wheels — good off-road performance!

The LM 620 has large wheels — this in conjunction with a tight turning circle makes it fast and nimble where space is restricted and over ground with poor bearing capacity.

Powerful, rugged engine!

The powerful, rugged 3-cylinder diesel engine with a wide speed range provides the machine with ample tractive power for every job.

Simple daily service!

Vital components of loader and engine are easily accessible for daily service.

Speed-coupling!

Time-saving speed-coupling in the implement attachment enables implements to be changed in less than a minute.



BOLINDER-MUNKTELL

—a member of the Volvo Group, Eskilstuna, Sweden

Nr 2166 GB