



Volvo Construction Equipment

C-SERIES SKID STEER LOADERS

Volvo Skid Steer Loaders ROC: 612-930 kg



Work comfortably

It's proven that less fatigue means more productivity. The Volvo cab has it all. It features comfortable operation, both at the controls and in regard to its low noise level. It also has plenty of personal space to make operators feel more at ease.

Comfort cab

The new skid steer loader cab is spacious and safe. It meets the ROPS/FOPS safety standards and offers operators 27% more space over previous models. Increased comfort means extended operator productivity.



Ample storage

Storage space is conveniently located under the left hand armrest. This easily accessible area gives the operator a secure place to store personal items such as keys. There is also a 12V power outlet here.



Interior noise

All models – both canopy and enclosed cab – are designed to limit noise in and around the operator environment. Less noise reduces operator fatigue and creates a more comfortable working environment.



Instrument consoles

Two consoles, positioned in the upper front cab corners, provide easy to read gauges. Simply presented instruments, situated for operator comfort, ensure easy viewing.





CAB ACCESS

Large side door allows operators to safely enter and exit the machine without climbing over an attachment. This minimizes the risk of slipping and the need to turn to sit down. Operators access the cab via a non-slip step. In a raised loader arm service position operators do not need to walk under the loader arm to engage the support strut.

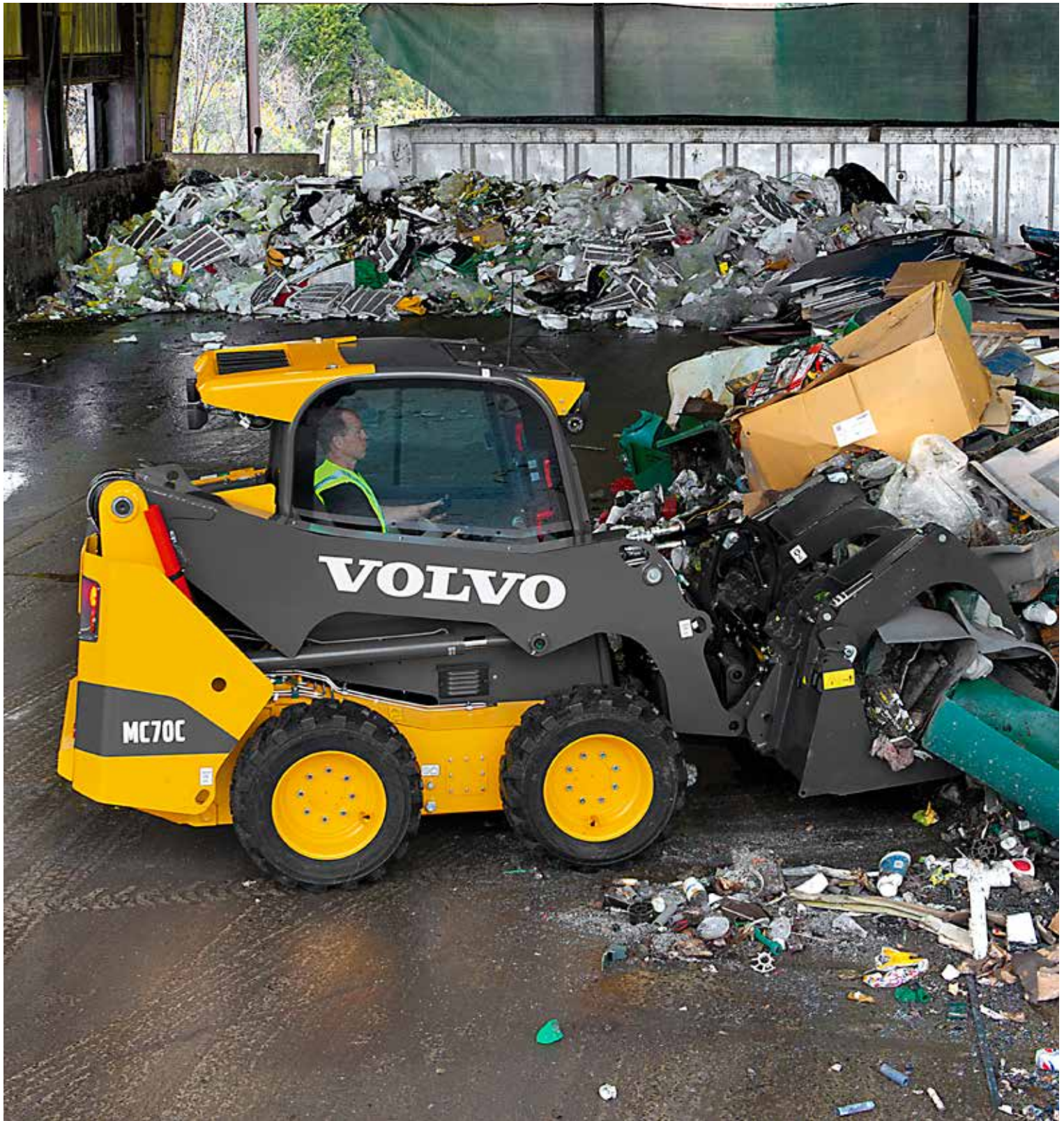

LOADER DESIGN

The unique single loader arm design delivers the loading performance and durability of a traditional machine but with the advantages of side entry and a single tower for improved visibility and safety.

Designed for performance

Our unique, single loader arm design affords operators many performance advantages. It's durable, it's safe and it provides excellent visibility. With high capacity and built in efficiency, you can perform at a higher level.

Vertical lift

Excellent vertical lift that is perfect for truck loading and material handling applications due to the increase in height and reach. Also delivers greater lift capacity for efficiency in repeated load and carry operations.



Radial lift

Radial lift path is the ideal design for ground engaging applications. It's strong, durable and easy to maintain. Radial lift offers increased levels of stability and remains the ideal choice for heavy-duty attachment applications.



Weight distribution

Weight is evenly distributed across the machine providing stability when handling both heavy and light loads. The offset cab and engine compartment counterbalance the unique single loader arm ensuring ultimate stability and balance from side to side.



Easier service - Longer life

Access greater uptime with user-friendly serviceability. Perform routine daily checks or access major components – it's all within easy access. This means you spend less time maintaining your machine and more time earning money.

O-ring face seals

Hydraulic connections use o-ring face seal (ORFS) fittings to eliminate hydraulic leaks. ORFS connectors reduce downtime and service costs by providing a 100% leak free joint.



Cab tilt

The entire cab can easily be tilted forward by one person with the removal of two bolts from the inside. Gas struts lock into place for simple, safe and quick access to key internal components.



Loader pivot pins

Our loader arm pivot pins are larger and therefore stronger than those used by competitors. They effectively distribute the load over the single arm design for longevity and durability.





SERVICE ACCESS

Easy service access due to single loader arm, forward tilting cab and large rear door. Simple access to service and maintenance items helps provide a longer operating life.

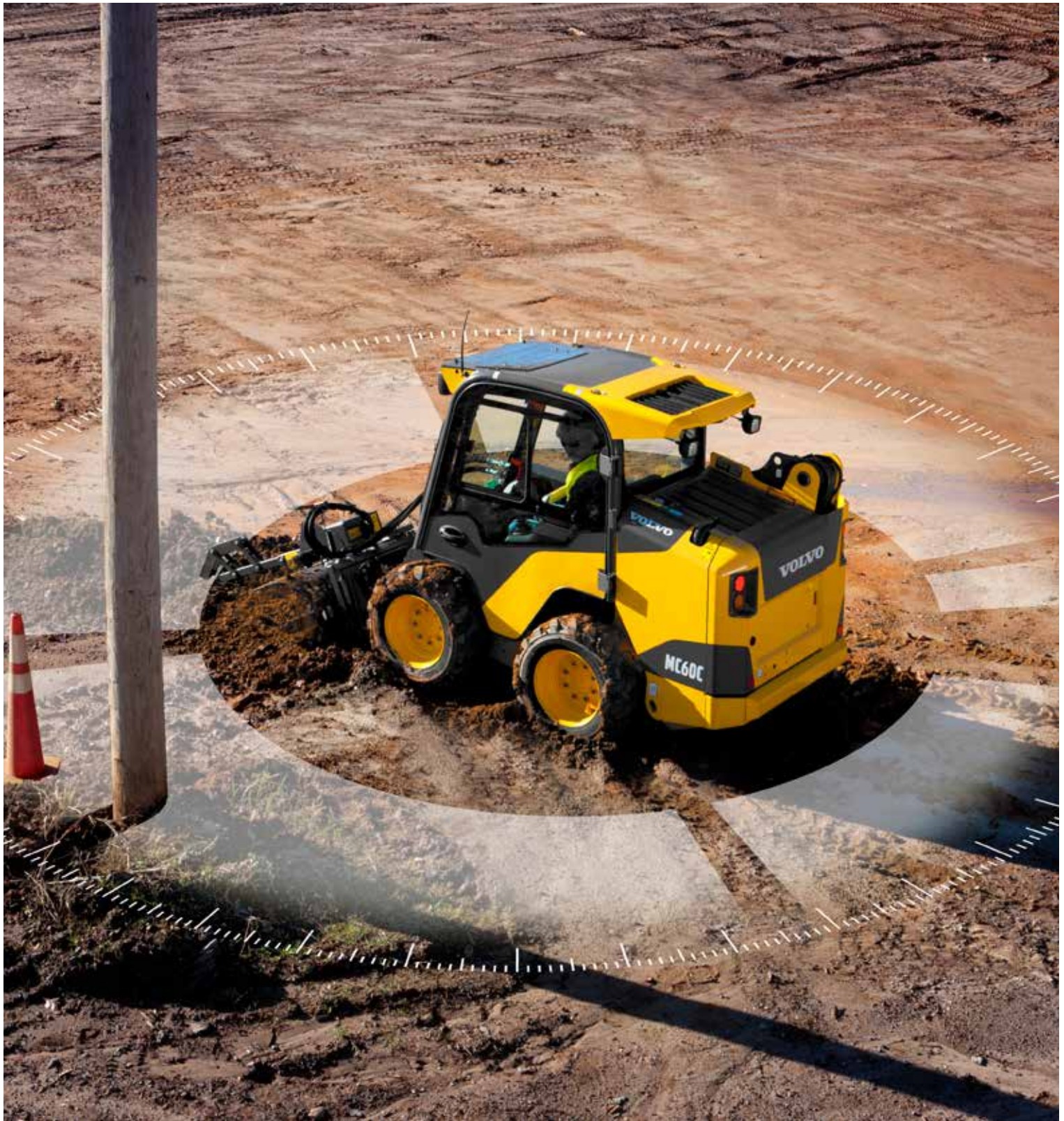

VISIBILITY

The single tower loader arm – with no horizontal cross member on the vertical lift model – provides superior visibility. The machine has a large top window and narrow ROPS cab pillars. The unique features help the operator maneuver the machine in tight areas to maximize productivity.

See it all - Do it all

You know the work is out there. And when you can see it all clearly, you get more of it done. Experience leading visibility all around the jobsite. Work in safety. Work with peace of mind. Work with your Volvo skid steer loader.

Loader arm service position

The side entry and exit cab makes engaging the loader arm support a one man operation. The operator can safely exit the machine to the side and walk round the rear without passing under the loader arm.



Cab door

The side door is the entire length of the cab. An unobstructed view provides improved visibility without the challenges found in other side mesh cages used in competitor machines. The door opens wide ensuring easy entry and exit.



Safety first

The large front window provides an emergency exit 2.5 times bigger than the rear emergency exit in traditional front entry machines. ROPS/FOPS and easy machine exit gives operators peace of mind in the unlikely event of machine roll-over or falling objects.



Take a spin around

VISIBILITY

Single tower loader arm and large top window for all-around, class-leading visibility.

Radial lift

Ideal loader path for heavy duty attachments and ground engaging applications.

Vertical lift

Ideal lift, height and reach for truck loading and material handling applications.

LOADER DESIGN

Single loader arm design for performance, durability, improved visibility and enhanced side-entry cab access.

Attachments

The versatility and power to use a wide range of attachments in a multitude of applications.

Versatility

Increased flexibility to handle more jobs with just one machine.





CAB

Designed for space, safety and comfort with ROPS/FOPS and large emergency exit.

CAB ACCESS

Safer side entry access eliminates the need to climb over a muddy and slippery bucket or attachment.

SERVICE ACCESS

Simple, safe access to all service and maintenance areas with a forward-tilting cab and a large rear compartment door.

CUSTOMER SUPPORT

Volvo will support your skid steer loader with all the parts and service assistance you need.

Attach and go

Unleash your machine's true potential with our extensive range of attachments. Our attachments work hard for you increasing your productivity and profitability across segments including building, landscaping, demolition and road construction.

A sample of some of the attachments offered

Auger

Powerful, smooth and easy for fast, effective ground hole drilling. Accepts multiple auger bits for application versatility. Hydraulically powered. Protected couplings for dependability, long life and lower costs.



Pallet forks

For pallet and material handling. Heavy-duty design provides fork strength to handle all the loads. Maximum open space between frame structure. Ideal visibility for fast, safe material handling.



6 in 1 bucket

Provides versatile material handling to dig, load, dump, push, grapple and level. Adds machine flexibility for a wide range of applications. Provides good visibility to the attachment edge.



Trencher

Ideal for utility trenching and pipe laying. High torque hydraulic motor. Heavy-duty design for dependability and long life. Provides maximum digging power for faster work. Greater versatility for increased profit opportunity.



Hydraulic breaker

Break through hard materials quickly and easily! Delivering consistent impact energy and superior performance, diaphragm breakers require much less maintenance.



Landscape bucket

Provide versatility and material retention. Long bucket floor length for excellent material retention. Optimal view of the cutting edge for fast, precision grading. Durable, long lasting performance even in tough conditions.



Scrap grapple

The easy way to handle bulky or loose material of varying sizes, not just in scrap applications. High-capacity handling with outstanding material retention. Provides excellent ground visibility for safe handling. Strength and durability for long life.



Broom

A wide range of brooms are available for versatility to suit multiple applications. Ideal for fast and effective site cleanup, public maintenance, debris pickup and more. Provides an optimal view for safe, quick work.





CUSTOMER SUPPORT

Rely on your local Volvo dealer for all the support services you need. They've got the tools to help you achieve more and increase profits.

Built to run - Supported for life

Volvo will support your skid steer loader with all the parts and service assistance you need. We have a strong team of local dealers on hand to assist you to make sure your machines perform at their best and have a long operating life. Volvo won't let you down.

Dealer support network

Whatever you do, wherever you go, your Volvo Construction Equipment dealer is there with you – around the globe. A comprehensive range of dependable Volvo equipment. Trusted industry experience. Reliable parts and service support. Your local Volvo dealer is in the right place to find the right solution.



State-of-the-art machines require state-of-the-art support and your Volvo dealer can provide a catalogue of services designed to get the most out of your machine, helping you maximise uptime, productivity and resale value. Your local Volvo dealer can provide a number of sophisticated support offers, including: Service plans ranging from routine wear inspections, through to comprehensive maintenance and repair agreements.

Analysis and diagnostics to help you understand how your machine is running, highlight potential maintenance issues and identify where performance can be improved.



Service and support

Your dealer is ready to help increase your uptime by attending to your service needs and offering expert support. With trusted industry experience and solutions for all your jobs, Volvo offers first class support.



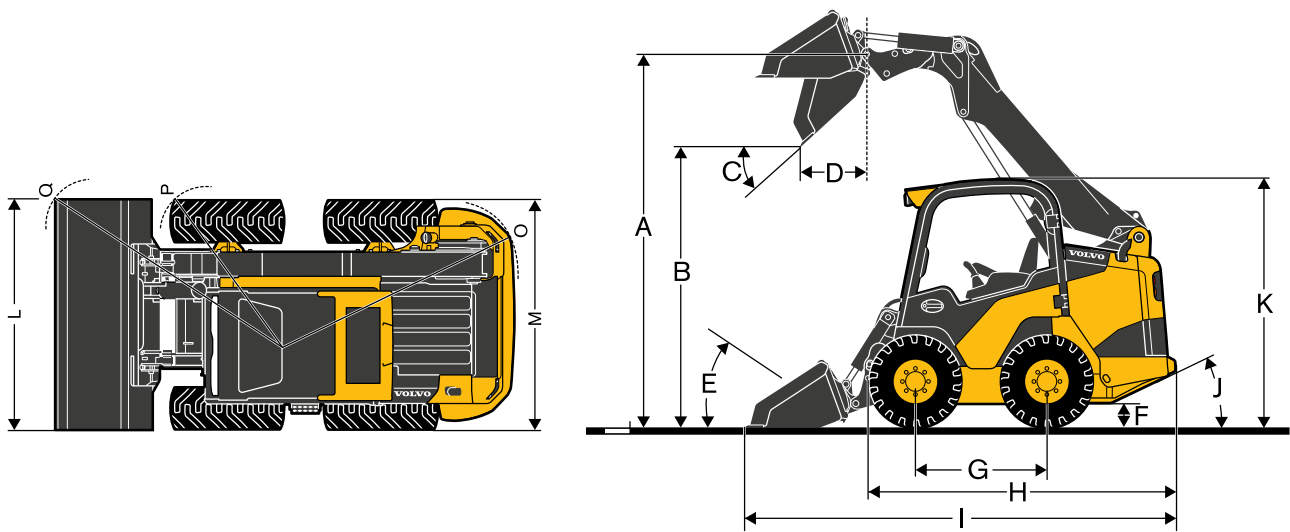

Specifications

		MC60C	MC70C	MC85C	MC95C	MC105C
Engine						
Model		404D-22	404D-22T	404D-22T	404D-22T	404D-22T
Cylinders		4	4	4	4	4
Fuel type		Diesel	Diesel	Diesel	Diesel	Diesel
Displacement	cm ³	2 200	2 200	2 200	2 200	2 200
Aspiration		Naturally aspirated	Turbo	Turbo	Turbo	Turbo
Cooling system		liquid	liquid	liquid	liquid	liquid
Horsepower						
SAE gross power	kW	35.7	44.7	44.7	44.7	44.7
	hp	48.5	60.8	60.8	60.8	60.8
Max. net power	kW	35.1	43.9	43.9	43.9	43.9
	hp	47.7	59.7	59.7	59.7	59.7
at engine speed	r/min	2 800	2 800	2 800	2 800	2 800
	r/min	1 200	1 200	1 200	1 200	1 200
Max. gross torque	Nm	143	189	189	189	189
at engine speed	r/min	46.6	46.6	46.6	46.6	46.6
Electrical system						
Battery	V/Ah	12/109	12/101	12/101	12/101	12/101
Alternator	Ah	65	85	85	85	85
Starter	kW	2	2	2	2	2
Drivetrain						
Tires		10x16.5 - 8 PR	10x16.5 - 8 PR wide	10x16.5 - 8 PR wide	10x16.5 - 8 PR wide	10x16.5 - 8 PR wide
Hydraulics system-loader						
Std hydraulic pump output	l/min	70	70	70	70	70
High flow pump output	l/min		100	100	100	100
at engine speed	r/min	2 800	2 800	2 800	2 800	2 800
System pressure	MPa	23	23	23	23	23
Service capacities						
Cooling system	l	15	15	15	15	15
Engine crankcase with filter, change	l	10.6	10.6	10.6	10.6	10.6
Fuel tank	l	98	98	98	98	98
Hydraulic system - total capacity	l	43.5	43.5	43.5	43.5	43.5
Hydraulic reservoir capacity	l	26	26	26	26	26
Performance						
Lift arm path		Radial	Radial	Vertical	Vertical	Vertical
Rated operating capacity (SAE)	kg	612	703	794	862	930
Tipping capacity (SAE)	kg	1 356	1 406	1 587	1 723	1 859
Operating weight (SAE)	kg	2 752	2 844	3 011	3 127	3 237
Breakout force, lift	kg	1 440	1 770	1 570	1 570	1 570
Breakout force, curl	kg	1 820	1 820	2 140	2 140	2 140
Maximum travel speed						
Single speed	km/h	12	12	12	12	12
Two speed	km/h		9 / 18.5	9 / 18.5	9 / 18.5	9 / 18.5
Cycle time						
Raise (lifting)	s	2.8	3.2	4.3	4.3	4.3
Lower (power down)	s	1.4	1.8	2.7	2.7	2.7
Curl	s	1.4	1.4	1.6	1.6	1.6
Dump	s	1.8	1.8	2	2	2

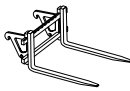

	Units	MC60C	MC70C	MC85C	MC95C	MC105C	
A	Height to hinge pin	mm	3 000	3 000	3000	3 000	3 000
B	Dump height	mm	2 260	2 260	2 260	2 260	2 260
C	Dump angle	°	42	42	42	42	42
D	Dump reach	mm	560	560	860	860	860
E	Roll back angle	°	30	30	30	30	30
F	Ground clearance	mm	210	210	210	210	210
G	Wheelbase	mm	1 070	1 070	1 070	1 070	1 070
H	Overall length (L/bucket)	mm	2 740	2 740	2 780	2 780	2 780
I	Overall length (W/bucket)	mm	3 490	3 490	3 530	3 530	3 530
J	Angle of departure	°	25	25	25	25	25
K	Overall height	mm	1 980	1 980	1 980	1 980	1 980
L	Bucket width	mm	1 524	1 676	1 676	1 676	1 676
M	Over tire width (L/bucket)	mm	1 520	1 600	1 600	1 600	1 600
O	Turning radius rear	mm	1 650	1 650	1 650	1 650	1 650
P	Turning radius front L/bucket	mm	1 010	1 010	1 140	1 140	1 140
Q	Turning radius front W/bucket	mm	2 090	2 090	2 090	2 090	2 090

Pallet forks MC60C MC70C MC85C MC95C MC105C		Overall height	Overall width	Overall length	Adjustable tine spacing		Pallet fork rating	Overall weight
		mm	mm	mm	mm	mm	kg	kg
		PF-42	984	1 194	1 313	229	1 143	2 722
PF-48	984	1 194	1 466	229	1 143	2 722	218	

Data according to bucket type	Bucket									
		Width					Length	Height	Weight	Heaped cap
		mm					mm	mm	kg	m³
MC60C MC70C MC85C MC95C MC105C	General Purpose Bucket	1 372	800	521	136	0.33				
	General Purpose Bucket	1 524	800	521	146	0.36				
	General Purpose Bucket	1 676	800	521	200	0.39				
	General Purpose Bucket	1 829	800	521	215	0.43				
	Landscape Bucket	1 372	953	521	148	0.4				
	Landscape Bucket	1 524	953	521	160	0.45				
	Landscape Bucket	1 676	953	521	217	0.49				
	Landscape Bucket	1 829	953	521	232	0.54				
	Multi Purpose Bucket	1 524	953	701	203	0.35				
	Multi Purpose Bucket	1 676	953	701	259	0.45				
Multi Purpose Bucket	1 829	953	701	352	0.57					

Equipment

STANDARD AND OPTIONAL EQUIPMENT

- = Standard
- O = Optional

	MC60C	MC70C	MC85C	MC95C	MC105C
Engine					
4-cylinder, liquid-cooled, 8-valve, indirect-injection diesel engines	•	•	•	•	•
Meets US EPA-Tier 4i, EU St3A	•	•	•	•	•
Self-cleaning, dual-element, air cleaner	•	•	•	•	•
12-Volt heavy-duty starter	•	•	•	•	•
Alternator with internal regulator	•	•	•	•	•
Grid heater	•	•	•	•	•
Quick cycle engine preheat	•	•	•	•	•
Engine oil remote drain hose	•	•	•	•	•
High-capacity radiator	•	•	•	•	•
Spark arrestor muffler	o	o	o	o	o
External pre-cleaner (cyclonic type)	o	o	o	o	o
Cab, canopy equipment					
Canopy, isolation mounted canopy, FOPS & ROPS, with low left-hand side door	•	•	•	•	•
Cabin, isolation mounted, heated fully glazed sealed and pressurized, FOPS & ROPS, washer/wiper and sliding left hand window	o	o	o	o	o
Right-hand laminated glass	•	•	•	•	•
Cab access step	•	•	•	•	•
Top window	•	•	•	•	•
In-cab rearview mirror	•	•	•	•	•
Interior light	•	•	•	•	•
Pod storage area	•	•	•	•	•
12-Volt power accessory outlet	•	•	•	•	•
Cup holder	•	•	•	•	•
Secondary exit through front windshield	•	•	•	•	•
Radio with Auxiliary input	o	o	o	o	o
In-cab fuse panel	•	•	•	•	•
Control panel					
Engine start/stop key switch	•	•	•	•	•
Electronic hand throttle	•	•	•	•	•
Electric lift and tilt hydraulic lockouts	•	•	•	•	•
Park brake switch	•	•	•	•	•
Full audible and visual warning systems (Charge pressure, Coolant temperature, Hydraulic oil and Engine oil pressure, Air filter restriction, Alternator, Low Fuel Level)	•	•	•	•	•
Fuel gauge	•	•	•	•	•
Coolant temperature gauge	•	•	•	•	•
Hydraulic oil temperature gauge	•	•	•	•	•
Hourmeter	•	•	•	•	•
Controls					
3-way function levers	•	•	•	•	•
7-way function levers, with 14-pin connector	o	o	o	o	o
ISO hand electro hydraulic controls	•	•	•	•	•
Operator modes	•	•	•	•	•
Control pattern selection: ISO or H-pattern	o	o	o	o	o
Foot throttle	•	•	•	•	•

STANDARD AND OPTIONAL EQUIPMENT

- = Standard
- O = Optional

	MC60C	MC70C	MC85C	MC95C	MC105C
Seats and seat belts					
Operator seat bar	•	•	•	•	•
Mechanical suspension seat	•	•	•	•	•
Air suspension seat, heated, vinyl, with adjustable control pods	o	o	o	o	o
2" retractable seat belt	•	•	•	•	•
3" retractable seat belt	o	o	o	o	o
Three points two inches retractable seat belt	o	o	o	o	o
Lighting and warning					
2 front 50-Watt work lights	•	•	•	•	•
1 rear 50-Watt work lights (2 if AC)	•	•	•	•	•
Additional (2nd) 50-Watt work light (if no AC)	o	o	o	o	o
Rotating beacon	o	o	o	o	o
Back-up alarm with rear light	•	•	•	•	•
Road light kit including left and right hand side rear view mirrors	o	o	o	o	o
Loader arm and Hydraulic functions					
Radial lift	•	•	•	•	•
Parallel lift (raise)	•	•	•	•	•
Lift-arm mounted auxiliary hydraulics (Flat face couplers)	•	•	•	•	•
Low flow case drain return line	•	•	•	•	•
Mechanical attachment bracket	•	•	•	•	•
Float function	•	•	•	•	•
Creep speed control	o	o	o	o	o
Driveline, undercarriage					
2 servo-assisted variable displacement piston pumps mounted in tandem	•	•	•	•	•
2 fixed displacement high torque motors	•	•	•	•	•
Standard duty lug tires	•	•	•	•	•
Heavy-duty lug tires	o	o	o	o	o
Heavy-duty wide flotation lug tires	o	o	o	o	o
Hydraulic park brake	•	•	•	•	•
Maintenance					
Lockable rear service door and engine cover	•	•	•	•	•
Heavy-duty, maintenance-free battery – 1 000CCA	•	•	•	•	•
Master electrical shut-off switch	•	•	•	•	•
Lockable fuel cap	•	•	•	•	•
Tilting canopy/cab	•	•	•	•	•
Lift-arm support strut	•	•	•	•	•
Emergency boom lower valve	•	•	•	•	•
Protection					
Heavy duty rear guard	o	o	o	o	o
LH fender and fuel cap cover for canopy	o	o	o	o	o

SELECTION OF VOLVO OPTIONAL EQUIPMENT

Reversible fan



2-speed option helps you get the job done faster



High flow auxiliary hydraulics



Heated cab with air conditioning for year-round comfort



Parallel-lift (attachment remains parallel to the ground throughout the raise cycle)



Not all products are available in all markets. Under our policy of continuous improvement, we reserve the right to change specifications and design without prior notice. The illustrations do not necessarily show the standard version of the machine.

VOLVO

Volvo Construction Equipment

www.volvoce.com